

# ALACHUA COUNTY STORMWATER TREATMENT MANUAL





Page intended to be blank

TABLE OF CONTENTS

LIST OF FIGURES..... IX

LIST OF TABLES ..... XI

**ACKNOWLEDGEMENTS .....XIII**

**EXECUTIVE SUMMARY .....XIV**

**CHAPTER 1. INTRODUCTION ..... 3**

1.1. PURPOSE AND INTENT .....3

1.2. STORMWATER INTRODUCTION.....3

1.3. LOCAL HYDROLOGIC AND WATER RESOURCE CONTEXT.....4

    1.3.1. *Rainfall Characteristics* .....4

    1.3.2. *Hydrologic Soil Properties*.....4

    1.3.3. *Aquifer Vulnerability Zones:* .....6

    1.3.4. *Alachua County Ground Water Resources*.....7

    1.3.5. *Alachua County Surface Waters and Watersheds* .....7

    1.3.6. *Discharges to Alachua County Water Bodies* .....10

1.4. ACRONYMS AND DEFINITIONS.....10

    1.4.1. *Acronyms*.....10

    1.4.2. *Definition of Terms* .....11

**CHAPTER 2. EVALUATING AND MASTER PLANNING A SITE ..... 24**

2.1. OVERVIEW .....24

2.2. CHANGES IN STORMWATER CHARACTERISTICS FROM URBAN DEVELOPMENT .....24

    2.2.1. *Changes in Urban Hydrology* .....24

    2.2.2. *Stormwater Pollutants and Removal Processes* .....25

2.3. GOALS OF STORMWATER MANAGEMENT.....28

    2.3.1. *General goals of stormwater management* .....28

    2.3.1. *Alachua County Comprehensive Plan - Stormwater Management Goals* .....29

2.4. INTRODUCTION TO STORMWATER MANAGEMENT .....29

2.5. INTRODUCTION TO LOW IMPACT DESIGN .....30

    2.5.1. *What is “Low Impact Design” (LID)* .....30

    2.5.2. *Advantages of LID*.....32

2.6. SITE PLANNING AND DESIGN .....34

2.7. REFERENCES CITED .....39

**CHAPTER 3. GENERAL STORMWATER REQUIREMENTS AND CRITERIA ..... 42**

3.1. INTRODUCTION.....42

3.2. COMPATIBILITY WITH STATE ENVIRONMENTAL RESOURCE PERMITTING (ERP) RULES .....42

3.3. CRITERIA FLEXIBILITY AND ALTERNATIVE DESIGNS .....42

3.4. PRESUMPTIVE CRITERIA.....42

3.5. APPLICABILITY OF STORMWATER MANAGEMENT REQUIREMENTS.....43

3.6. COUNTY/CITY APPROVAL AND AUTHORIZATIONS .....44



3.6.1. *Development Approval Required* ..... 44

3.6.2. *Exemptions* ..... 44

6. *Off-site compensating treatment facilities permitted and constructed prior to the effective date of this Article.* ..... 44

3.6.3. *Waivers* ..... 45

(a) *A waiver from specific requirements of this section may be granted by the County where a proposed building addition will not result in significant adverse impacts to stormwater quality; the environment; or public health, safety, or welfare. It is the property owners' burden to demonstrate that a waiver is warranted.* ..... 45

(b) *Development activities located on parcels with total land area less than 1 acre in size may be eligible for a partial waiver from the stormwater treatment Performance Standards in Section 77.21 based on a demonstration by the applicant that meeting these standards is not technically feasible. A technical feasibility analysis must be submitted to demonstrate that higher levels of treatment are not achievable.* ..... 45

3.6.4. *Documents Incorporated By Reference* ..... 45

3.7. FLOOD CONTROL REQUIREMENTS ..... 46

3.8. REQUIREMENTS IN CHAPTER 407, ARTICLE 9 – STORMWATER MANAGEMENT ..... 46

3.9. EROSION AND SEDIMENT CONTROL ..... 46

3.9.1. *Overview* ..... 46

3.9.2. *Erosion and Sediment Control Requirements* ..... 47

3.9.3. *Erosion and Sediment Control Principles* ..... 47

3.9.4. *Development of an Erosion and Sediment Control Plan* ..... 48

3.9.5. *Projects larger than 1 Acre Must Obtain NPDES CGP Coverage* ..... 48

3.10. INSPECTION OF STORMWATER TREATMENT SYSTEMS ..... 49

3.11. ADDITIONAL PERMITTING REQUIREMENTS TO PROTECT POTABLE WATER SUPPLIES ..... 50

3.12. HAZARDOUS OR TOXIC SUBSTANCES ..... 50

3.13. CO-MINGLING OFF-SITE AND ON-SITE STORMWATER RUNOFF ..... 50

3.14. PROFESSIONAL CERTIFICATION REQUIREMENTS ..... 50

**CHAPTER 4. STORMWATER QUALITY PERFORMANCE STANDARDS..... 52**

4.1. INTRODUCTION ..... 52

4.2. STORMWATER TREATMENT PROCESS FUNDAMENTALS ..... 52

4.3. STORMWATER TREATMENT PERFORMANCE STANDARDS ..... 54

4.4. SPECIAL BASIN CRITERIA ..... 55

4.4.1. SENSITIVE KARST AREAS ..... 55

4.4.2. *Projects within Watersheds of Impaired Water Bodies or Water Bodies with Adopted Total Maximum Daily Loads (TMDLs)* ..... 58

4.5. RAPID INFILTRATION STORMWATER RETENTION BASINS ..... 59

4.6. CALCULATING STORMWATER POLLUTANT LOADING ..... 60

4.6.1. *Calculation of Pre-Development and Post-Development Hydrology* ..... 60

4.6.2. *Calculation of Pre-Development (Current) Stormwater Pollutant Loading* ..... 64

4.6.3. *Calculation of Post-Development Stormwater Pollutant Loading* ..... 65

4.7. DESIGNING THE BMP TREATMENT TRAIN TO MEET REQUIRED LOAD REDUCTIONS ..... 65

4.8. COMPUTATIONAL AIDS ..... 66

4.9. REFERENCES ..... 66

**CHAPTER 5. CATALOG OF STORMWATER BEST MANAGEMENT PRACTICES ..... 70**

- 5.0. BEST MANAGEMENT PRACTICES .....70
  - 5.0.1. Introduction to BMPs.....70
- 5.1. SITE PLANNING BMPs .....73
  - SP1. Inventory Site Assets: Hydrology.....73
  - SP2. Inventory Site Assets: Topography.....73
  - SP3. Inventory Site Assets: Soils .....74
  - SP4. Inventory Site Assets: Vegetation .....74
  - SP5. Protect Surface Waters and Wetlands.....75
  - SP6. Preserve Open Space.....75
  - SP7. Natural Area Conservation - Retain Tree Canopy and Natural Landscaping .....76
  - SP8. Cluster Design and Maximize Gross Density .....77
  - SP9. Minimize Building Footprint.....78
  - SP10. Minimize Total Impervious Surface Area .....79
  - SP11. Minimize Directly-Connected Impervious Area (DCIA) .....79
  - SP12. Curb Elimination and Curb Cuts.....81
- 5.2. SOURCE CONTROL BMPs .....83
  - SC1. Retain Natural Landscape Depressions.....83
  - SC2. Use Selective Site Clearing and Grading .....83
  - SC3. Minimize Soil Disturbance and Compaction .....83
  - SC4. Build with the Landscape Slope .....85
  - SC5. Retain Native Landscapes at the Lot Level.....85
  - SC6. Florida-friendly Landscaping™ and Fertilizers .....85
  - SC7. Rainfall Interceptor Trees.....87
  - SC8. Install Efficient Irrigation Systems.....95
  - SC9. Use Non-Potable Water Supply for Irrigation .....96
  - SC10. Community and Homeowner Education .....96
- 5.3. STRUCTURAL STORMWATER BMPs .....96
- 5.3. RETENTION BASIN DESIGN CRITERIA .....98
  - 5.3.1. Description.....98
  - 5.3.2. Required Treatment Level and Associated Treatment Volume .....99
  - 5.3.3. Calculating Load Reduction Efficiency for a Given Retention Volume .....100
  - 5.3.4. Design Criteria .....100
  - 5.3.5. Required Site Information.....100
  - 5.3.6. Retention Basin Construction .....100
  - 5.3.7. Inspections, Operation and Maintenance .....101
- 5.4. EXFILTRATION TRENCH DESIGN CRITERIA .....103
  - 5.4.1. Description.....103
  - 5.4.2. Required Level of Treatment and Associated Treatment Volume .....104
  - 5.4.3. Calculating Load Reduction Efficiency for a Given Retention Volume .....104
  - 5.4.4. Design and Performance Criteria .....105
  - 5.4.5. Required Site Information.....106
  - 5.4.6. Construction requirements .....109
  - 5.4.7. Inspections, Operation and Maintenance .....110
- 5.5. UNDERGROUND STORAGE AND RETENTION SYSTEMS DESIGN CRITERIA .....111
  - 5.5.1. Description.....111
  - 5.5.2. Required Treatment Volume .....112

- 5.5.3. *Calculating Load Reduction Efficiency for a Given Retention Volume* ..... 112
- 5.5.4. *Design Criteria* ..... 113
- 5.5.5. *Required Site Information*..... 114
- 5.5.6. *Construction requirements*..... 114
- 5.5.7. *Inspections, Operation and Maintenance* ..... 114
- 5.6. **BIORETENTION AND RAIN GARDENS**..... 117
  - 5.6.1. *Description*..... 117
  - 5.6.2. *Required Treatment Volume* ..... 118
  - 5.6.2. *Calculating Load Reduction Efficiency for a Given Retention Volume* ..... 119
  - 5.6.3. *Design Criteria* ..... 119
  - 5.6.4. *Construction of the Rain Garden* ..... 121
  - 5.6.5. *Inspection and Maintenance* ..... 121
- 5.7. **VEGETATED SWALES** ..... 122
  - 5.7.1. *Description*..... 122
  - 5.7.2. *Swales with Swale Blocks or Raised Driveway Culverts (Linear Retention Systems)* ..... 124
  - 5.7.3. *Swales without Swale Blocks or Raised Driveway Culverts (Conveyance Swales)* ..... 124
  - 5.7.4. *Required Treatment Volume for Conveyance Swales* ..... 124
  - 5.7.6. *Calculating the Swale Length for Conveyance Swales* ..... 125
  - 5.7.7. *Design Criteria for Swales*..... 126
  - 5.7.8. *Soil Requirements and Testing Requirements* ..... 126
  - 5.7.9. *Construction and Stabilization Requirements* ..... 126
  - 5.7.10. *Inspections, Operation and Maintenance Requirements* ..... 127
- 5.8. **VEGETATED NATURAL BUFFERS**..... 128
  - 5.8.1. *Description*..... 128
  - 5.8.2. *Required Treatment*..... 130
  - 5.8.3. *Calculating Load Reduction Efficiency for a Given Retention Volume* ..... 130
  - 5.8.4. *Design Criteria* ..... 130
  - 5.8.5. *Required Site Information*..... 131
  - 5.8.6. *Construction Requirements* ..... 131
  - 5.8.7. *Inspections, Operation and Maintenance* ..... 132
- 5.9. **PERVIOUS PAVEMENT SYSTEMS** ..... 134
  - 5.9.1. *Description*..... 134
  - 5.9.2. *Applicability* ..... 135
  - 5.9.3. *Required Treatment Volume* ..... 136
  - 5.9.4. *Calculating Load Reduction Efficiency for a Given Retention Volume* ..... 136
  - 5.9.5. *Design Criteria* ..... 137
  - 5.9.6. *Required Site Information*..... 140
  - 5.9.7. *Construction requirements* ..... 140
  - 5.9.8. *Inspection, Operation and Maintenance* ..... 140
- 5.10. **GREENROOF WITH CISTERN SYSTEMS** ..... 150
  - 5.10.1. *Description*..... 150
  - 5.10.2. *Required Treatment Volume* ..... 151
  - 5.10.3. *Calculating Load Reduction Efficiency for a Given Retention Volume* ..... 151
  - 5.10.4. *Classification of Greenroof Surfaces* ..... 152
  - 5.10.5. *Design Criteria* ..... 153
  - 5.10.6. *Design Criteria for Management of the Filtrate* ..... 155

- 5.10.7. Construction requirements ..... 156
- 5.10.8. Inspections, Operation and Maintenance ..... 156
- 5.10.9. Greenroof with Cistern - Harvesting Design Curves and Equations ..... 157
- 5.11. RAINWATER HARVESTING ..... 160
  - 5.11.1. Description ..... 160
  - 5.11.2. Applicability and Siting Considerations ..... 163
  - 5.11.3. Required Treatment Volume ..... 163
  - 5.11.4. Design Criteria ..... 164
  - 5.11.5. Construction Requirements ..... 167
  - 5.11.6. Inspection, Operation, and Maintenance ..... 167
- 5.12. WET DETENTION SYSTEMS ..... 169
  - 5.12.1. Description ..... 169
  - 5.12.2. Treatment required ..... 170
  - 5.12.3. Bleed-down Volume ..... 170
  - 5.12.4. Design Criteria ..... 171
  - 5.12.5. Required Site Information ..... 175
  - 5.12.6. Detention Pond Construction ..... 178
  - 5.12.7. Inspections, Operation and Maintenance ..... 179
  - 5.12.8. Calculating Annual Residence Time ..... 179
- 5.13. STORMWATER HARVESTING SYSTEMS ..... 181
  - 5.13.1. Description ..... 181
  - 5.13.2. Treatment required ..... 182
  - 5.13.3. Equivalent Impervious Area ..... 182
  - 5.13.4. Design Criteria ..... 184
  - 5.13.5. Construction requirements ..... 186
  - 5.13.6. Inspections, Operation and Maintenance ..... 186
  - 5.13.7. Rate-Efficiency-Volume (REV) Curves ..... 187
- 5.14. FILTER SYSTEMS ..... 189
  - 5.14.1. Description ..... 189
  - 5.14.2. Treatment required ..... 190
  - 5.14.3. Expected Load Reduction ..... 191
  - 5.14.4. Design Criteria ..... 192
  - 5.14.5. Filter Media for Up-Flow Filters and Biofiltration Systems ..... 192
  - 5.14.6. Construction considerations ..... 194
  - 5.14.7. Inspections, Operation and Maintenance ..... 195
  - 5.14.8. References ..... 196
- 5.15. MANAGED AQUATIC PLANT SYSTEM (MAPS) DESIGN CRITERIA ..... 198
  - 5.15.1. Description ..... 198
  - 5.15.2. Nutrient Removal Effectiveness and Credits ..... 199
  - 5.15.3. Littoral Zone Design Criteria ..... 199
  - 5.15.4. Floating Wetland Islands or Mats ..... 205
- 5.16. BIOFILTRATION SYSTEMS ..... 206
  - 5.16.1. Description ..... 206
  - 5.16.2. Biosorption Activated Media (BAM) ..... 208
  - 5.16.3. Applicability ..... 208
  - 5.16.4. Design Considerations and Requirements ..... 212

5.16.5. *Biofiltration Design Procedure*.....217  
 5.16.6. *Biofiltration Design Example* .....217  
 5.16.7. *Operation and Maintenance* .....218  
 5.16.8. *Planter Box Biofiltration Systems* .....219  
 5.16.9. *Tree Box Filter Systems*.....221

**APPENDIX A. LIST OF ALACHUA COUNTY RECEIVING WATERS AND THEIR CURRENT IMPAIRMENT STATUS, TMDL STATUS, BMAP STATUS..... CCXXVI**

**APPENDIX B. RAINFALL ZONE 2 RETENTION BMP TREATMENT VOLUMES AND AVERAGE ANNUAL POLLUTANT LOAD REDUCTIONS. .... 245**

TABLE B1-1. REQUIRED RETENTION TREATMENT VOLUMES (IN INCHES) TO ACHIEVE AN 80% AVERAGE ANNUAL POLLUTANT LOAD REDUCTION IN RAINFALL ZONE 2.....CCXLVI

TABLE B2-1. DRY RETENTION BMP MEAN ANNUAL POLLUTANT LOAD REDUCTION FOR VARIOUS STORMWATER TREATMENT VOLUMES AS A FUNCTION OF DCIA AND NON-DCIA CURVE NUMBER FOR METEOROLOGICAL ZONE 2..... CCXLVII

**APPENDIX C. METHODOLOGIES ..... CCLVI**

C.1. METHODOLOGIES, RECOVERY ANALYSIS, AND SOIL TESTING FOR RETENTION SYSTEMS ..... CCLVI  
 C.1.1. *Description*..... cclvi  
 C.1.2. *Required Treatment Volume (RTV)*..... cclvii  
 C.1.3. *Recovery Time of the RTV*..... cclvii  
 C.1.4. *Infiltration Processes* ..... cclviii  
 C.1.5. *Accepted Methodologies for Determining Retention BMP Recovery* ..... cclix  
 C.1.6. *Requirements, Guidance and Recommendations for Manual Computations or Computer Simulations*..... cclix  
 C.1.7. *Requirements, Guidance and Recommendations for BMP Soil Testing*..... cclxiii  
 C.1.8. *Sediment Sump Design Example* ..... cclxvii

**APPENDIX D. STORMWATER RETROFIT PROJECTS ..... CCLXIX**

DESCRIPTION..... CCLXIX  
 GOALS AND PERFORMANCE STANDARDS..... CCLXIX  
 DESIGN AND SELECTION OF APPLICABLE BMPs ..... CCLXIX

**List of Figures**

*Figure 1.1. Alachua County Hydrologic Soil Groups Distribution* \_\_\_\_\_ 4  
*Figure 1.2. Alachua County Aquifer Vulnerability Map*\_\_\_\_\_ 6  
*Figure 1.3. Nitrate Concentrations in Alachua County Ground Water* \_\_\_\_\_ 7  
*Figure 1.4. Alachua County Water Bodies and Wetlands* \_\_\_\_\_ 8  
*Figure 1.5. Alachua County Watersheds* \_\_\_\_\_ 9  
*Figure 2.1. Stormwater flow changes associated with urbanization.* \_\_\_\_\_ 24  
*Figure 2.2. How Impervious Cover Affects the Water Cycle* \_\_\_\_\_ 25  
*Figure 2.3. The Nitrogen Cycle transforms nitrogen into nitrogen gas* \_\_\_\_\_ 28

Figure 2.4. Environmental Resources Assessment Checklist \_\_\_\_\_ 36

Figure 2.5. Stormwater LID BMPS at the Lot Scale \_\_\_\_\_ 37

Figure 2.6. Stormwater LIDs at the Lot Scale (Medera Model Home) \_\_\_\_\_ 37

Figure 4.1. Stormwater Treatment Tradeoff – Particle Size vs. Hydraulic Loading \_\_\_\_\_ 53

Figure 4.2. Alachua County Aquifer Vulnerability Map \_\_\_\_\_ 56

Figure 4.3. Soil Drainage Classes \_\_\_\_\_ 57

Figure 4.4. Annual Rainfall Isoleths in Alachua County \_\_\_\_\_ 62

Figure 5.2.1. Tree planting guidelines. (Adapted from Flott, 2004 and ISA, 2003b) \_\_\_\_\_ 92

Figure 5.3.1. Typical Cross-section of “Dry” Retention Basin \_\_\_\_\_ 99

Figure 5.4.1. Cross-section of a “Dry” Exfiltration Trench (N.T.S.) \_\_\_\_\_ 105

Figure 5.4.2. Typical Exfiltration Trench Sumps and Dead End Details \_\_\_\_\_ 107

Figure 5.4.3. Detail for Exfiltration Trench Trash Baffle \_\_\_\_\_ 108

Figure 5.4.4. Generic Detail for a Typical Exfiltration Trench Trash Tee \_\_\_\_\_ 109

Figure 5.5.1. Generic Underground Retention System \_\_\_\_\_ 112

Figure 5.6.1. Typical Cross-Section of a Rain Garden \_\_\_\_\_ 118

Figure 5.6.2. Schematic and Photo of Rain Garden \_\_\_\_\_ 120

\_\_\_\_\_ 120

Figure 5.7.1. Typical Cross-section of a Conveyance Swale without Swale Blocks \_\_\_\_\_ 123

Figure 5.8.1. Plan View Schematic of Typical Vegetative Natural Buffer \_\_\_\_\_ 129

Figure 5.9.1. Typical Pervious Pavement Cross Section \_\_\_\_\_ 135

Figure 5.9.2. Pervious Pavement System Cross Section #1 \_\_\_\_\_ 142

Figure 5.9.3. Pervious Pavement System Cross Section #2 \_\_\_\_\_ 143

Figure 5.9.4. Typical Pervious Pavement System Cross Section #3 \_\_\_\_\_ 144

Figure 5.9.5. Plan View of ERIK In-Situ Infiltrometer - (Embedded Ring Infiltration Kit) \_\_\_\_\_ 145

Figure 5.9.6. ERIK Measuring Tube \_\_\_\_\_ 146

Figure 5.9.7. Pervious Pavement Site Plan \_\_\_\_\_ 147

Figure 5.9.8. Pervious Pavement Site Plan \_\_\_\_\_ 148

Figure 5.9.9. Pervious Pavement Site Plan \_\_\_\_\_ 149

Figure 5.10.1a. Extensive Greenroof Section (Usually Passive Function) \_\_\_\_\_ 152

Figure 5.10.1b. Intensive Greenroof Section (Usually Active Function) \_\_\_\_\_ 152

Figure 5.10.2. Greenroof Harvesting Design Curve for Gainesville, Florida Area \_\_\_\_\_ 158

Figure 5.10.3. Greenroof with Cistern Harvesting Equation for Gainesville, Florida Area \_\_\_\_\_ 158

Figure 5.11.1. Rate Efficiency Volume (REV) Curve for a Rainwater Harvesting System \_\_\_\_\_ 164

in Alachua County with Constant Daily Demand \_\_\_\_\_ 164

Figure 5.12.1. Typical Cross Section of a Wet Detention System \_\_\_\_\_ 170

Figure 5.12.2. Removal Efficiency of Total Phosphorus in Wet Detention Ponds \_\_\_\_\_ 172

as a Function of Residence Time \_\_\_\_\_ 172

Figure 5.12.3 Removal Efficiency of Total Nitrogen in Wet Detention Ponds \_\_\_\_\_ 172

as a Function of Residence Time \_\_\_\_\_ 172

Figure 5.12.4. Typical Wet Detention Outfall Structure (N.T.S.) \_\_\_\_\_ 176

Figure 5.12.5. Typical Wet Detention Outfall Structure with "V"-notch Weir (N.T.S.) \_\_\_\_\_ 177

Figure 5.12.6. Typical Wet Detention Outfall Structure With and Without Baseflow Conditions (N.T.S.) \_\_\_\_\_ 177

Figure 5.12.7. Examples of Good and Poor Wet Detention Pond Configurations (N.T.S.) \_\_\_\_\_ 178

Figure 5.13.1. Typical Cross Section of a Stormwater Harvesting System \_\_\_\_\_ 183

Figure 5.13.2. Schematic for a Typical Stormwater Harvesting Pond \_\_\_\_\_ 185

Figure 5.13.3. Schematic for Two Typical Stormwater Harvesting Withdrawal Systems \_\_\_\_\_ 185

Figure 5.13.4. REV Curve for Alachua County \_\_\_\_\_ 188

Figure 5.14.1a. Off-line Up-Flow Filter Schematic \_\_\_\_\_ 191

Figure 5.14.1b. Top View of Diversion Box to Off-Line Filter \_\_\_\_\_ 191

Figure 5.14.2. Typical Schematic of an Up-flow Filter after Wet Detention \_\_\_\_\_ 194

with Water Flow Direction Shown \_\_\_\_\_ 194

Figure 5.16.1. Plan View Illustrating a Biofiltration System \_\_\_\_\_ 209

Figure 5.16.2. Cross Section View of a Biofiltration System \_\_\_\_\_ 209

Figure 5.16.3. Example Cross Section View for Nitrate Removal with Overflow \_\_\_\_\_ 210

Figure 5.16.4. Example Stormwater Planter Box Biofiltration System \_\_\_\_\_ 210

Figure 5.16.5. Example Stormwater Infiltration Planter Box Biofiltration System \_\_\_\_\_ 211

Figure 6.16.6. Stormwater Tree Box Filter System \_\_\_\_\_ 211

Figure 5.16.7. Example Average Annual Runoff Capture Efficiency \_\_\_\_\_ 216

of a Biofiltration System in Alachua County for Specific Conditions \_\_\_\_\_ 216

Figure C.1.1. Ground Water Mounding Beneath a Retention System \_\_\_\_\_ cclviii

**List of Tables**

Table 1.1. Characteristics of NRCS Hydrologic Soil Groups Classifications \_\_\_\_\_ 5

Table 2.1. Functional Aspects and Timing of LID BMPs \_\_\_\_\_ 38

Table 3.1. Stormwater Treatment System Recertification Frequency \_\_\_\_\_ 49

\_\_\_\_\_ 53

Table 4.1. Basic Mechanisms of Stormwater Treatment \_\_\_\_\_ 53

Table 4.2. Example Land Use Categories Matrix to Calculate Loadings \_\_\_\_\_ 60

Table 4.3. Mean Annual Runoff Coefficients (C Values) as a Function of DCIA Percentage and Non-DCIA Curve Number (CN) for Alachua County. \_\_\_\_\_ 63

Table 4.4. Stormwater Pollutant Loading Input Data \_\_\_\_\_ 64

Table 5.1. Stormwater BMP Strategies Checklist \_\_\_\_\_ 71

Table 5.2.1. Methods for Addressing Urban Planting Constraints \_\_\_\_\_ 91

Table 5.10.1. Plants that have been successfully used on greenroofs in Florida \_\_\_\_\_ 154

Table 5.12.1. Relationship between TP and TN Load Removal and Wet Detention Residence Time \_\_\_\_\_ 173

Table 5.14.1. Filter Media and Removal Effectiveness. \_\_\_\_\_ 195

\_\_\_\_\_ 195

Table 5.15.1. Nutrient Removal Credits for MAPS \_\_\_\_\_ 199

Table 5.15.2. Native Plant Species Suitable for Littoral Zone Plantings or Adjacent to Wet Detention Ponds \_\_\_\_\_ 200

Table C.1.1. Accepted Methodologies for Retention BMP Recovery \_\_\_\_\_ cclix

**HOW TO USE THIS DOCUMENT**

Underlined blue words include terms that are defined in Section 1.4, Terminology, are bookmarks to other sections within the Manual, or are links to web pages that provide information. If you click on these words, you will be taken to either the part of the document where the term is defined or explained, to the other section in the Manual, or to an external web site.

For Word 2016, Click on “File,” then on “Options,” then on “Customize ribbon”. For earlier versions of Word, use the Word web support to find out how to “Customize the ribbon.”

In “Choose commands from” drop-down menu, select “All Commands”.

From the list of commands find “Back” and click “Add”

Similarly, find “Forward” and click “Add”

In PDF, after clicking on the [blue](#) word, to get back to your original part of the document, follow these steps:

- Click on “View” at the top of the screen
- Click on “Page Navigation”
- Click on “Previous View”



# ACKNOWLEDGEMENTS

Alachua County and the developers of this Manual gratefully acknowledge the vision and work of the local governments that pioneered development of Low Impact Design and Development Manuals and the contributions of all those who assisted with those Manuals. Portions of the Alachua County Stormwater Treatment Manual incorporate significant parts of the following documents:

- Draft Alachua County Low Impact Development (LID) Design Manual, September 2011
- [Sarasota County Low Impact Development Guidance Document \(May 2015\)](#)
- [Pinellas County Stormwater Management Manual](#) (2016)
- [Draft Florida Department of Environmental Protection and Water Management Districts Environmental Resource Permit Stormwater Quality Applicant's Handbook](#) (March 2010)  
Note that this Applicant's Handbook was not adopted by the agencies.

Design criteria for many of the Low Impact Design BMPs in this Manual have been updated from the above documents based on results from monitoring and effectiveness projects completed since 2010. Many of the LID BMP research documents can be downloaded from:

- <http://www.dep.state.fl.us/water/nonpoint/pubs.htm> - [Urban Stormwater BMP Research Reports](#)
- <https://stormwater.ucf.edu/>
- <http://www.dot.state.fl.us/> - search for "stormwater research"

Additionally, parts of the Alachua County Stormwater Management Manual were taken from materials on the Alachua County Web Site.

# EXECUTIVE SUMMARY

Alachua County has extensive surface and ground water resources that are highly vulnerable to nonpoint source pollution because of the county's soils, geology, and hydrologic conditions. In fact, many of the County's springs and water bodies are "impaired" and do not meet their applicable water quality standards. Total Maximum Daily Loads (TMDLs) and Basin Management Action Plans (BMAPs) have been adopted by FDEP for many of these impaired waters. As a NPDES MS4 permit holder, Alachua County is required to implement management actions to reduce pollutant loadings to these impaired water bodies and meet the pollutant load allocations established in TMDLs or BMAPs. In recognizing these facts and conditions, this Manual was created to promote an advanced stormwater management approach that incorporates a variety of nonstructural and structural stormwater treatment Best Management Practices (BMPs), including newer low impact design BMPs that can be integrated into a BMP Treatment Train to address stormwater pollution loadings from new development and redevelopment.

This Manual was created to provide a comprehensive and systematic approach to project stormwater design. Stormwater management, including water quantity and quality, should be approached in a holistic manner considering the setting, natural hydrology, existing conditions, project type, and community character. Stormwater management needs to be focused and integrated into the projects' core design using a variety of methods for addressing stormwater.

This Manual establishes stormwater treatment performance standards to better protect surface and ground waters and design and operational criteria for stormwater BMPs to achieve the performance standards. A primary focus of the Manual is to promote the use of multiple Low Impact Design BMPs as part of a BMP treatment train. The Manual's requirements align with the State of Florida Environmental Resource Permit (ERP) and the administrative standards established by the St. Johns River and Suwannee River Water Management Districts. The County, through its codes and policies, will allow design flexibility while establishing quantity/quality goals to ensure a sustainable future.

This manual is designed in three distinct parts that each address the stages of the stormwater design process:

- **Part A: Introduction and Site Planning** – Chapter 1 and 2 address the purpose and intent of the stormwater management and how it relates to Alachua County. It also establishes the community's expectation as to how sites are designed, redeveloped, and maintained. This includes an introduction to the concepts of Low Impact Design (LID).
- **Part B: Alachua County Stormwater Requirements** – Chapters 3 and 4 establish the overall standards for stormwater flood control and treatment within Alachua County. This includes performance standards and technical requirements.
- **Part C: Best Management Practices Catalog** – Chapter 5 contains specific design criteria and operational requirements for the stormwater treatment BMPs that are approved in Alachua County. The Manual includes 12 Site Planning BMPs, 10 Source Control BMPs, and 14 Structural BMPs. Each BMP contains specific design criteria, operation and maintenance standards, and other details. The BMPs are intended to be used as an integrated BMP Treatment Train to achieve the required level of treatment to protect surface and ground waters. A minimum of two Low Impact Design BMPs are required in each stormwater treatment system.

# ALACHUA COUNTY STORMWATER TREATMENT MANUAL



## PART A



Page intended to be blank

# CHAPTER 1. INTRODUCTION

## 1.1. Purpose and Intent

The Alachua County Stormwater Treatment Manual (Manual) establishes the minimum stormwater treatment requirements to enhance the protection or restoration of the County's surface and ground water resources. It also includes applicable flood control requirements for projects within the unincorporated portions of Alachua County. The Manual is to be used primarily by professionals engaged in planning, designing, constructing, operating, and maintaining stormwater treatment systems associated with development and redevelopment projects in Alachua County. Potential users include, but are not limited, to stormwater design engineers, natural resource managers, planning officials and administrators, building officials, architects, landscape architects, site design specialists, and landscape operations and maintenance professionals.

## 1.2. Stormwater Introduction

This Manual provides design, construction, and operational criteria, specifications, and technical guidance for stormwater treatment systems in Alachua County. The Manual particularly focuses on stormwater [Best Management Practices](#) (BMPs) used to provide advanced stormwater treatment, in compliance with applicable Alachua County or Municipal codes, to prevent discharges that cause or contribute to violations of State water quality standards in both surface and ground waters. This manual also includes requirements to minimize erosion and sedimentation during construction and to minimize flooding.

The requirements associated with both the National Pollutant Discharge Elimination System (NPDES) Municipal Stormwater (MS4) permit and the number of impaired water bodies within Alachua County, including those with adopted Total Maximum Daily Loads (TMDLs) or Basin Management Action Plans (BMAPs), create a greater need to reduce stormwater pollutant loads to improve water quality. Additionally, the County recognizes that non-conventional stormwater treatment practices, such as Low Impact Design BMPs, are essential to encourage and support quality development and redevelopment that is critical to sustaining the local economy. The MS4 permit program requires jurisdictions to revisit their land development codes to ensure they promote low impact design to effectively support water quality improvement goals. The Manual addresses that requirement and, within unincorporated Alachua County, promotes the Alachua County Comprehensive Plan approach of a more holistic approach to resource management using an integrated/synergistic review of stormwater, flood control, wetland, landscaping, open space, and habitat protection and enhancement considerations.

The Alachua County Stormwater Treatment Manual functions as a toolbox of nonstructural and structural stormwater Best Management Practices (BMPs) that can be applied to a variety of [development](#) and [redevelopment](#) opportunities to satisfy regulatory standards. As many of the receiving waters in Alachua County are [impaired](#) for certain pollutants, a net environmental benefit approach to reducing stormwater pollutant loadings discharged from the site is a major focus of this Manual.

### 1.3. Local Hydrologic and Water Resource Context

Alachua County lies in the North-central portion of the Florida peninsula and is part of the Central Highlands or Central Florida Ridge of the Atlantic Coastal Plain. Its 965 square miles are comprised of low, flat limestone plain in the west bounded by a west-facing escarpment (steep slope) and a flat upland plateau in the east. Elevations in the County range from approximately 25 feet above sea level near the Santa Fe River to over 195 feet northwest of Gainesville.

#### 1.3.1. Rainfall Characteristics

Alachua County typically receives between 50 and 54 inches of precipitation annually. Its rainfall characteristics are like other counties in Rainfall Zone 2 as delineated by [Harper and Baker \(2007\)](#). The nearest meteorological site with hourly data (located in Branford, FL) indicates that approximately 86% of North Central Florida’s 105 mean annual rainfall events are less than 1 inch in volume, with approximately 39% of all rainfall events less than 0.10 inch. Since 1998, over 90% of the storm events in Alachua County have been less than 1”. The mean number of dry days between rain events (Inter-Event Time) in North Central Florida was 4.4 days during the dry season and 2.14 days during the wet season. (Harper and Baker, 2007).

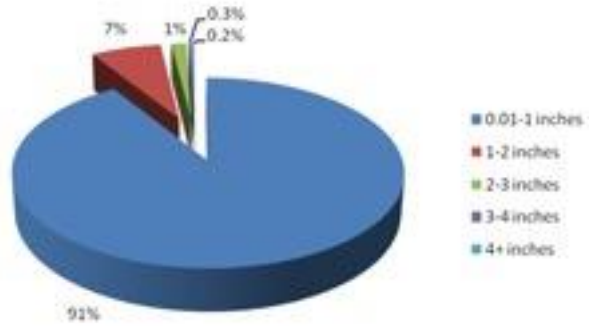

#### 1.3.2. Hydrologic Soil Properties

Alachua County has a diverse set of soils with different hydrological properties. Understanding the soil properties of a specific site can help determine stormwater management design and features necessary to maximize efficiency and effectiveness of a given stormwater management design.

Figure 1.1. Alachua County Hydrologic Soil Groups Distribution

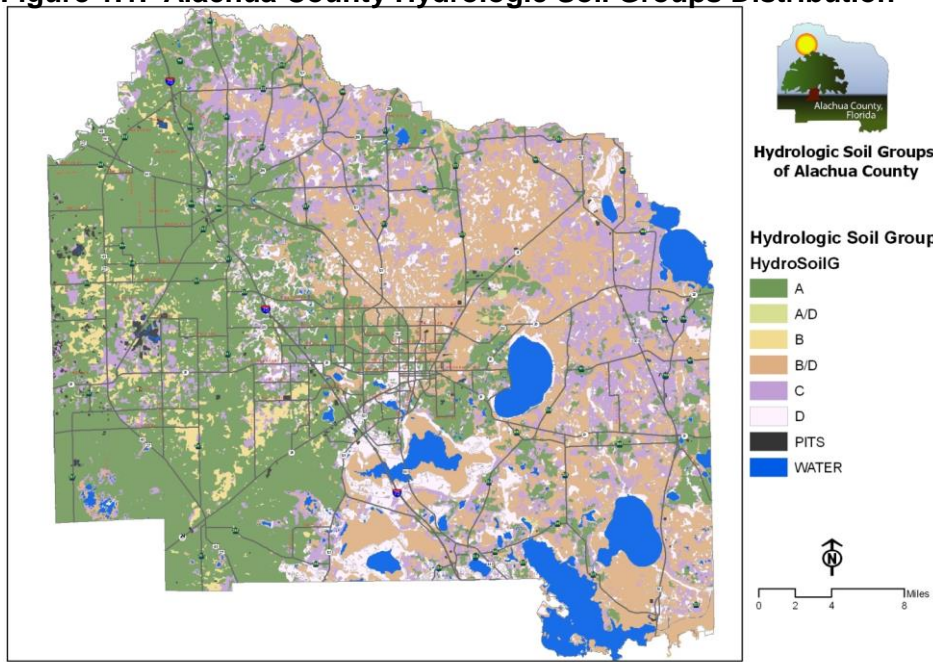

DISCLAIMER: This map and the spatial data it contains are made available as a public service, to be used for reference purposes only. The Alachua County Environmental Protection Department provides this information AS IS without warranty of any kind, implied or expressed, regarding accuracy, completeness, or fitness of use. The quality of the data is dependent on the various sources from which each data layer is obtained.

Two of the most important site characteristics that will determine the type and nature of stormwater BMPs that can be successfully used at any site are the hydrologic soil types and the [seasonal high water table](#)



conditions. This is especially true for [retention](#) BMPs that have the greatest potential to reduce stormwater volumes and pollutant loadings discharged to surface waters. Soils with good infiltration potential (aka low runoff potential) should be considered as optimal locations for [Low Impact Design](#) (LID) stormwater management practices that use infiltration.

The USDA Natural Resources Conservation Service revised the *Alachua County Detailed Soil Survey* in 2014. This publication provides good information about the soil types in Alachua County and their properties including data on the elevation of the seasonal high water table. Figure 1.1 shows the location of the soil types in Alachua County based on their Hydrologic Soil Groups.

The NRCS classifies soils into Hydrologic Soil Groups (HSG). HSGs are categorized according to the percolation rate of water when the soils are thoroughly wet and receive precipitation from long-duration storms. Group A soils are generally deep, well-drained sands with high infiltration rate and low runoff potential. These soils also have a high rate of water transmission and cover 50.4% of the county, mainly in western and central Alachua County. Retention BMPs work very well on HSG A soils. An additional 21% of the County has A/D soils. Retention BMPs also work well on Group B soils, which cover 4.5% of the county. Group B soils have a moderate infiltration rate and moderate rate of water transmission. Group C soils cover 2.5% of the county with Group C/D soils covering 9.8%. They have a slow infiltration rate when thoroughly wet, and consist primarily of fine textured soils with a slow rate of water transmission. Group D soils only cover 2.2% of the county. They have a very slow infiltration rate and very slow rate of water transmission. These soils generally have a high clay component and high runoff potential Table 1.1 below summarizes the characteristics of the HSG classifications.

**Table 1.1. Characteristics of NRCS Hydrologic Soil Groups Classifications**

Hydrologic Soil Group	Infiltration Rate		Water Transmission Rate	Runoff Potential	Notes
	When Dry	When Wet			
<b>A</b>	High	High	High	Low	
<b>B</b>	Moderate	Moderate	Moderate	Moderate	
<b>C</b>	Slow	Slow	Slow	High	
<b>D</b>	Very Slow	Very Slow	Very Slow	Very High	
<b>A/D</b>	High	Very Slow	Variable	Very High	High SHGWT
<b>B/D</b>	Moderate	Very Slow	Variable	Very High	High SHGWT
<b>C/D</b>	Slow	Slow	Slow	High	High SHGWT

Another important hydrologic characteristic of soils is the “Drainage Class” which refers to the frequency and duration of wet periods. Seven classes of natural soil drainage are recognized: excessively drained, somewhat excessively drained, well drained, moderately well drained, somewhat poorly drained, poorly drained, and very poorly drained. Approximately 23.2% of the county’s soils are excessively drained or well

drained with these soils primarily in Western Alachua County. About 15% of the soils are moderately well drained. The poorly drained classes comprise about 41% of the county, mainly in Eastern Alachua County.

**1.3.3. Aquifer Vulnerability Zones:**

Alachua County is in a transition zone for the [Floridan Aquifer](#), which supplies most of the County’s residents with (Figure 1.2). The eastern portion of the county is generally a lower vulnerability aquifer zone, meaning that there is an impermeable or semi-permeable layer of clay separating surface water from the Floridan Aquifer. Surface wetlands and water bodies distinguish this portion of the county. The depth of the confining layer varies, and should be determined on a site-by-site basis. Running northwest to central south through the county is the vulnerable aquifer zone, which is distinguished by sinkholes and depressions that penetrate the confining layer and feed directly to the Floridan Aquifer. Stormwater in this zone cannot be directed into sinkholes or directly to the Floridan Aquifer because untreated stormwater poses ground water contamination risks. The western edge of the county is a high vulnerability aquifer zone. A development site’s location with respect to aquifer vulnerability zones plays a role in determining the available and optimal stormwater BMPs and their design.

**Figure 1.2. Alachua County Aquifer Vulnerability Map**

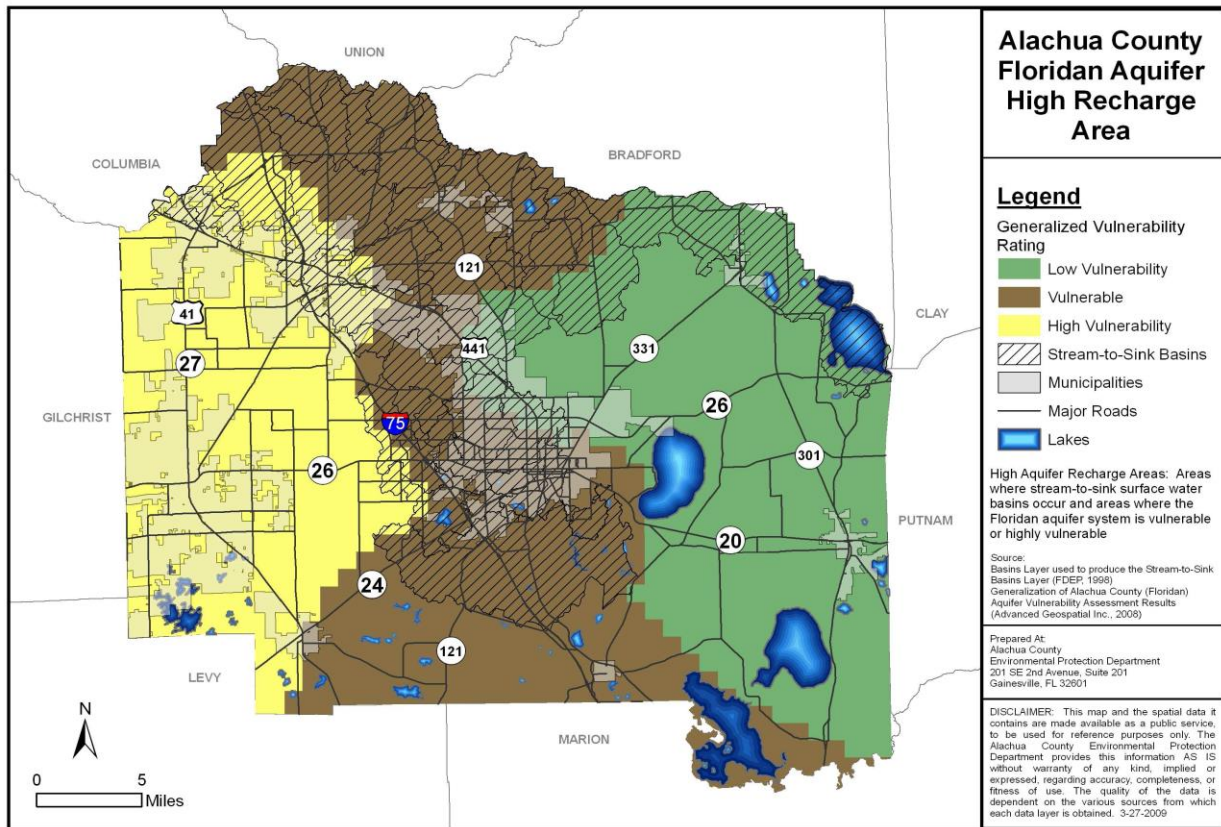



**1.3.4. Alachua County Ground Water Resources**

The ground water aquifer is the principal source of water for domestic, agricultural, and industrial use in Alachua County. There are three aquifer systems present in Alachua County: the surficial aquifer system, the intermediate aquifer system and the Floridan Aquifer system. The Floridan Aquifer system underlies the entire County. The surficial and intermediate aquifer systems are present only in the eastern portion of the County.

Ground water quality is generally good. However, with the potential for ground water pollution, particularly in the area where the Floridan Aquifer is unconfined and the numerous stream to sink basins, the amount of nitrate in the ground water and our springs is increasing as seen in Figure 1.3.

**Figure 1.3. Nitrate Concentrations in Alachua County Ground Water**

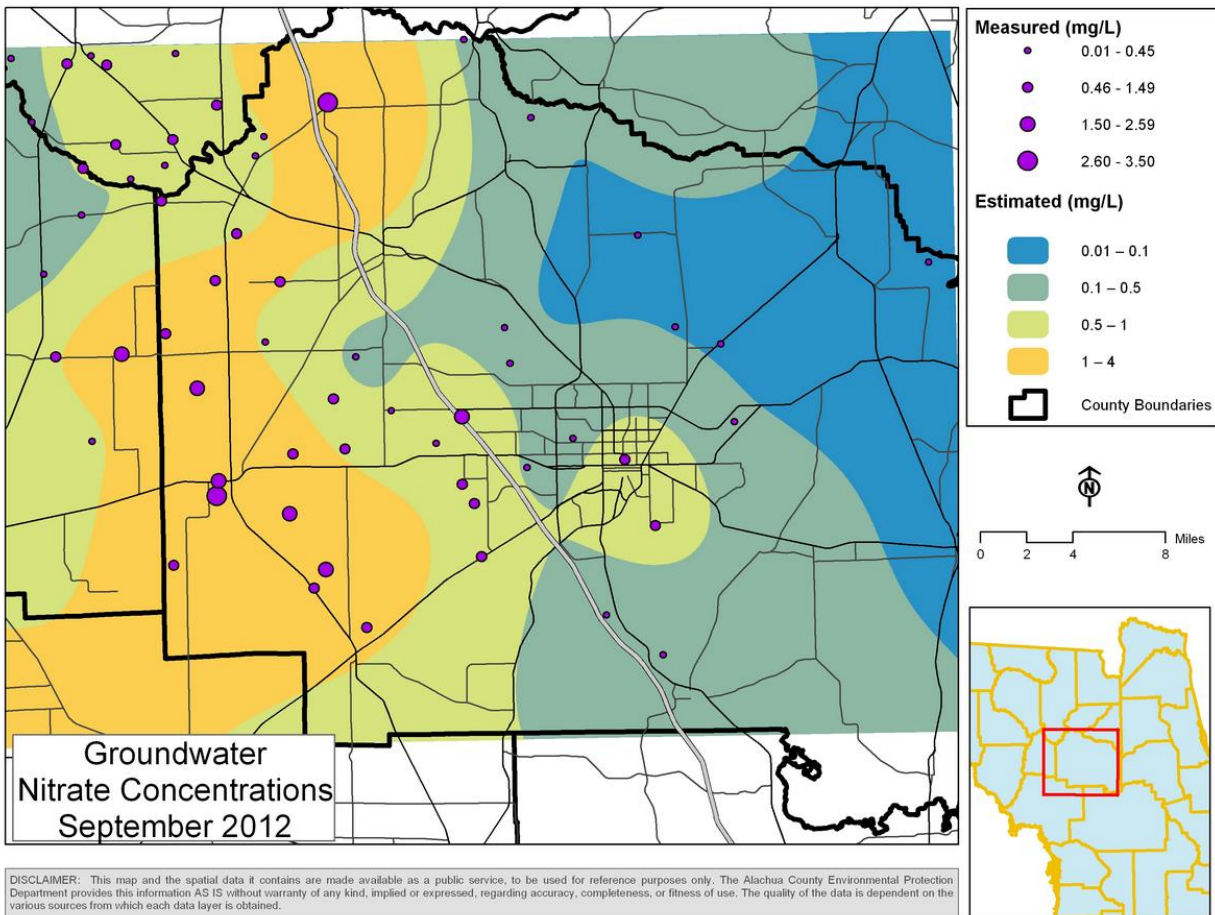

**1.3.5. Alachua County Surface Waters and Watersheds**

The surface water systems of Alachua County include areas of standing and flowing water, whether permanent, intermittent, or temporary, as well as the wetlands and floodplains associated with them. The rivers and streams that flow through Alachua County historically meandered through broad floodplains. Because of urbanization and agriculture, these broad

floodplains have been restricted to narrower belts along the rivers and streams or otherwise modified for flood control.

Surface water types in Alachua County include sand-bottomed creeks, large calcareous streams, springs, lakes, ponds, and wetlands. The county’s underlying geology and soils have a profound influence on the location of surface water bodies with most of them occurring in the eastern part of the county (Figure 1.4).

[Appendix A](#) lists the major receiving waters in Alachua County that have been assigned [Water Body Identification Numbers](#) (WBIDs) by FDEP. This table also includes information about the impairment status of these water bodies along with information on whether a [Total Maximum Daily Load](#) (TMDL) or [Basin Management Action Plan](#) (BMAP) has been adopted for the water body

**Figure 1.4. Alachua County Water Bodies and Wetlands**

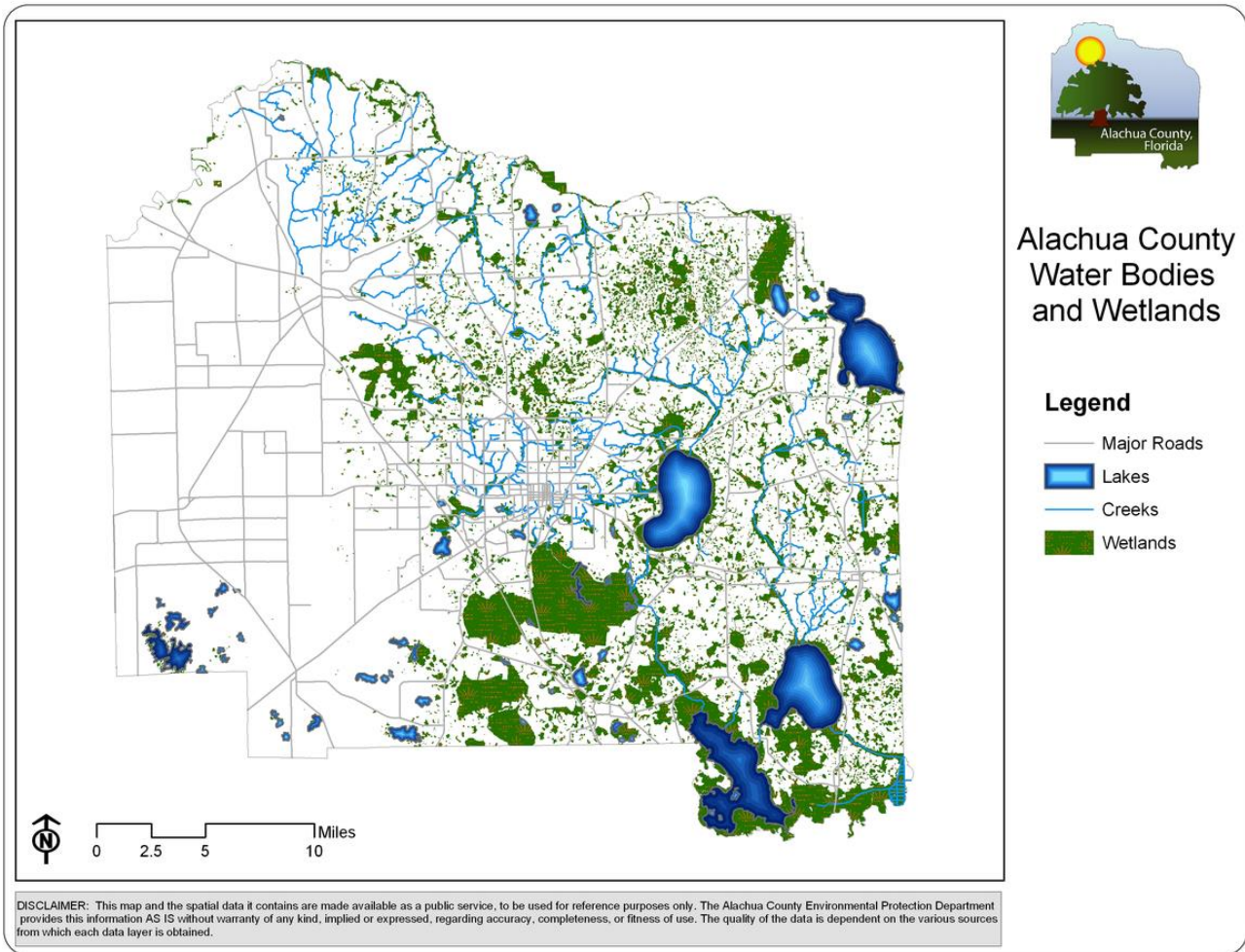

A watershed is an area of land that drains to a receiving body of water. For example, depending on the location in Alachua County, stormwater runoff from lawns and driveways travels down the street along the gutter to a storm drain then runs through underground pipes to a neighborhood pond or stream. From there it drains to downstream receiving waters such as



the Santa Fe River, Orange Lake, Newnan's Lake or Payne's Prairie. Alachua County has 61 designated watersheds as see below in Figure 1.5.

Figure 1.5. Alachua County Watersheds

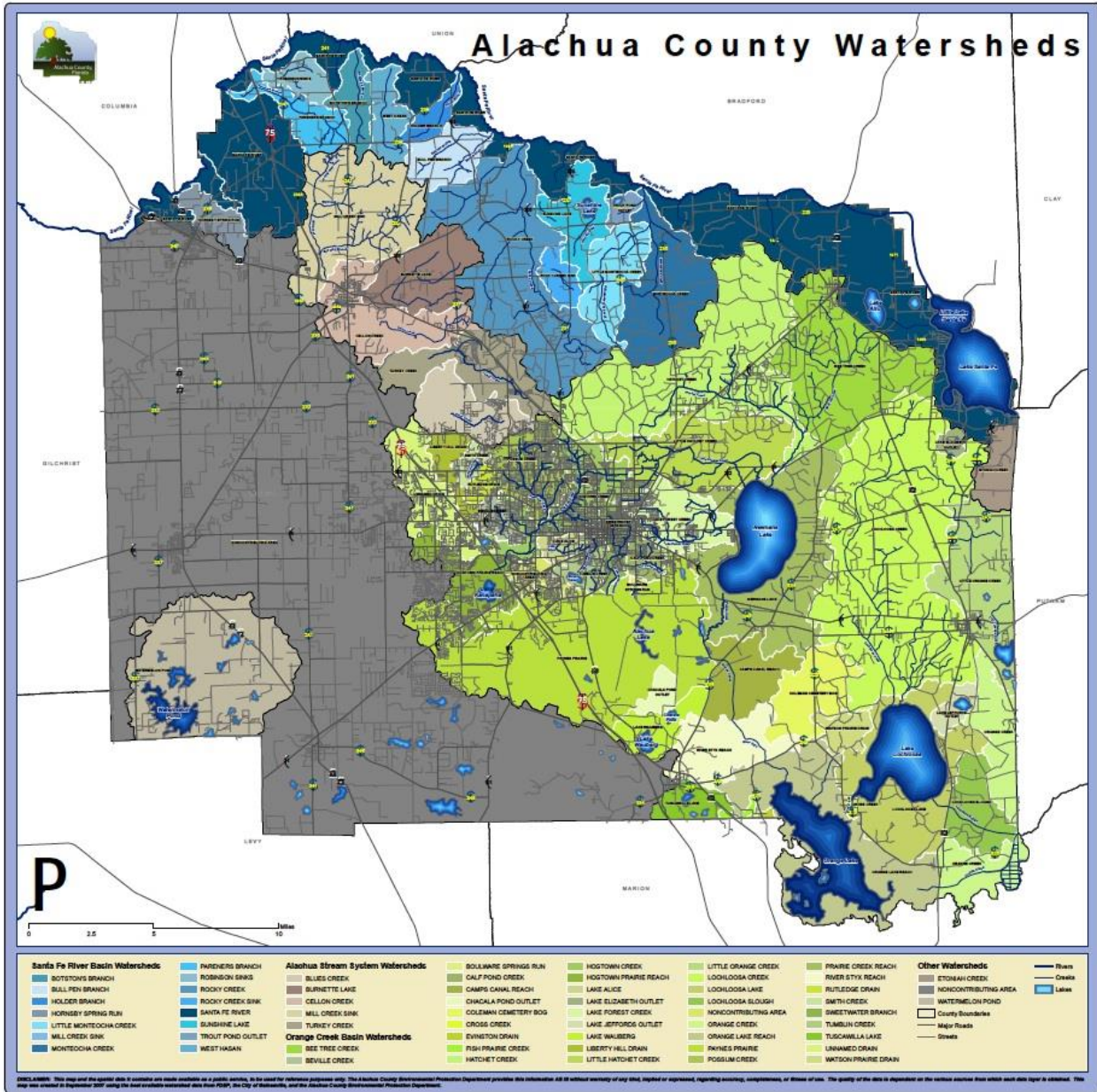

Alachua County, in cooperation with the SRWMD, SJRWMD, FDEP, and other entities, conducts monitoring of its water bodies to determine their health. As part of the state's Rotating Basin Cycle, the FDEP conducts assessments of water body health on a five-year schedule. The product of this assessment is a list of all water bodies within a basin and their current health status. Information about these assessments is available online at:

FDEP Watershed Assessment - <http://www.dep.state.fl.us/water/watersheds/assessment/>

As part of the water body assessment, a list of water bodies that do not meet the state's water quality standards is produced. This is called the Verified List of Impaired Surface Waters. These [impaired waters](#) undergo a long-term planning and implementation process to restore their beneficial uses and health by reducing pollutant loadings discharged into them from throughout their watershed. This process includes the development and adoption of Total Maximum Daily Loads (TMDLs) that establish the pollutant loading capacity for a water body to be healthy and the pollutant load reductions that must be done in the water body's watershed to meet the TMDL and restore the water body. In many cases, a Basin Management Action Plan (BMAP) is prepared by FDEP and watershed stakeholders to create a blueprint for reducing pollutant loads and restoring the water body's health. [Appendix A](#) lists Alachua surface water bodies with a WBID number. It includes whether a water body WBID is impaired, a TMDL has been adopted, whether a BMAP has been adopted, and the percent load reductions required by the TMDL. It is current as of July 2017. For more recent information, please see the web sites below.

- The adopted Verified Lists of Impaired Waters are available online at: <http://www.dep.state.fl.us/water/watersheds/assessment/a-lists.htm> - al
- The adopted Total Maximum Daily Loads are listed in Chapter 62-304, F.A.C. It is available at: <https://www.flrules.org/gateway/ChapterHome.asp?Chapter=62-304>
- The adopted TMDL documents are available at: [http://www.dep.state.fl.us/water/tmdl/final\\_tmdl.htm](http://www.dep.state.fl.us/water/tmdl/final_tmdl.htm)

### 1.3.6. Discharges to Alachua County Water Bodies

Alachua County has adopted by reference the State of Florida's [Water Quality Standards](#) that are adopted in [Chapter 62-302](#), Florida Administrative Code. Under Florida law (Chapters 373 and 403, Florida Statutes), most discharges to Florida water bodies are not allowed without a permit. To obtain a permit one must demonstrate that the discharge will not cause or contribute to violations of water quality standards in the receiving water body. If a water body fails to meet water quality standards under existing conditions, including any water body on the Verified List of Impaired Waters, no additional discharges of the pollutant causing the water body impairment are allowed. However, [Section 373.414\(1\)\(b\)3](#), F.S., allows one to obtain a permit to discharge to an impaired water body if one can demonstrate "net environmental improvement." This means that the pollutant loading in the new discharge must be less than is currently being discharged from the site.

Because of the number of impaired water bodies in Alachua County, many future development and redevelopment projects will be required to meet the "net improvement" treatment standard for their stormwater discharges. The Alachua County Stormwater Management Manual has been developed to expand the "stormwater BMP toolbox" to allow projects to proceed cost-effectively while meeting the stormwater treatment requirements. To simplify the permitting process, Alachua County has defined "net improvement" for nitrogen and phosphorus loadings in the Basin Specific Performance Standards set forth in [Section 5.3](#).

## 1.4. Acronyms and Definitions

### 1.4.1. Acronyms

BAM = Biosorption Activated Media

BMAP = Basin Management Action Plan

- BMP = Best Management Practice
- CN = Curve Number
- EIA = Equivalent Impervious Area
- EMC = Event Mean Concentration
- ERP = Environmental Resource Permit
- FAC = Florida Administrative Code
- FDEP = Florida Department of Environmental Protection
- FS = Florida Statute
- ULDC = Alachua County Unified Land Development Code
- LID = Low Impact Design (AKA Low Impact Development)
- R.T.V. = Required treatment volume
- SJRWMD = St. Johns River Florida Water Management District
- SRWMD = Suwannee River Water Management District
- SHGWT= Seasonal High Water Table
- TMDL = Total Maximum Daily Load
- WBID = Water Body Identification

**1.4.2. Definition of Terms**

The following definitions are provided for use in Manual. Projects located in unincorporated Alachua County are also subject to the additional definitions in Article 3, Defined Terms, in Chapter 410 of the ULDC.

<i>Term</i>	<i>Definition</i>
“10-year storm event”	A rainfall event having a ten percent probability of occurrence during any given year.
“25-year storm event”	A rainfall event having a four percent probability of occurrence during any given year.
“100-year storm event”	A rainfall event having a one percent probability of occurrence during any given year.
“100-year floodplain”	See “Flood hazard area”
“Adverse impact” (upon a natural resource):	Direct contamination, alteration, or destruction, or that which contributes to the contamination, alteration, or destruction of a natural resource, or portion thereof, to the degree that its environmental benefits are or will be eliminated, reduced or impaired.

<i>Term</i>	<i>Definition</i>
“Adverse stormwater impacts”	Runoff from heavy precipitation that can result in flooding outside of normal floodplains, erosion and loss of property or life.
“Alteration”	Human-caused activity that modifies, transforms, or otherwise changes the land and/or vegetation, including, but not limited to: removal, displacement, mowing, or disturbance (severe pruning, hat-racking or internodal cutting, or poisoning) of vegetation excluding permitted prescribed burns; removal, displacement, demucking or disturbance of soil, rock, minerals or water within a plant's root zone; introduction of livestock; placement of vehicles, structures, debris, fill or other material objects thereon, including introduction or injection of water and other substances; use of mechanical equipment, including vehicle rutting, within a plant's root zone; dredging or excavation of land; construction of new structures or expansion of existing structures; installation of utilities, roads, stormwater management systems, septic tanks, bulkheading, fencing, agricultural activities, site preparation, land clearing, tree cutting, mechanized vegetation removal, contouring, placement of bridges or culverts, extraction of stumps or submerged logs, and the disposal of solid or liquid waste.
“Aquifer”	A geologic formation, group of formations, or part of a formation that contains sufficient saturated, permeable material to yield significant quantities of water to wells and springs.
“Aquifer, Florida system”	The thick carbonate sequence that includes all or part of the Paleocene to early Miocene Series and functions regionally as a water-yielding hydraulic unit. Where overlaid by either the intermediate aquifer system or the intermediate confining unit, the Floridan contains water under confined conditions. Where overlaid directly by the surficial aquifer system, the Floridan may or may not contain water under confined conditions, depending on the extent of low permeability materials in the surficial aquifer system. Where the carbonate rocks crop out, the Floridan generally contains water under unconfined conditions near the top of the aquifer system; but, because of vertical variations in permeability, deeper zones may contain water under confined conditions. The Floridan Aquifer system is present throughout the county and is the deepest part of the active ground water flow system. The top of the aquifer system generally coincides with the absence of significant thicknesses of clastics from the section and with the top of the vertically persistent permeable carbonate section. For the most part, the top of the aquifer system coincides with the top of the Suwannee Limestone, where present, or the top of the Ocala Group. Where these are missing, the Avon Park Limestone or permeable carbonate beds of the Hawthorn Formation form the top of the aquifer system. The base of the aquifer system coincides with the appearance



<i>Term</i>	<i>Definition</i>
	of the regionally persistent sequence of anhydrite beds that lie near the top of the Cedar Keys Limestone
Biosorption Activated Media (BAM)	Engineered media for use in stormwater BMPs to increase the removal of pollutants, especially nutrients.
Basin Management Action Plan (BMAP)	A "blueprint" for restoring impaired waters by reducing pollutant loadings to meet the allowable loadings established in a Total Maximum Daily Load (TMDL). These implementation plans are developed with local stakeholders--they rely on local input and local commitment--and they are adopted by FDEP Secretarial Order to be enforceable.
Best management practices (BMPs)	Structural and non-structural control techniques used for a given set of site conditions that based on research, field-testing, and expert review, have been determined to be effective and practicable for improving water quality, preventing erosion and sedimentation, conserving water supplies and protecting natural resources. Best management practices include, but are not limited to, site planning, turf and landscape practices, structural stormwater management facilities, maintenance procedures, prohibitions of practices, spill and leak control, and other good housekeeping measures for pollution prevention. Best management practices may be implemented individually or as a combination of practices such as a stormwater treatment train.
BMP Treatment Train	A series of complementary BMPs that are integrated into an effective stormwater management system with each BMP providing incremental stormwater attenuation and/or treatment benefits
"Buffer"	An area of planted or natural vegetation or open space maintained for various purposes, including reduction of erosion and siltation along surface waters and wetlands, reduction of poaching and wind erosion along roads and field edges, provision of wildlife travel corridors and habitat, and for separation of adjacent land uses or properties from one another.
"Closed Drainage Basin"	Any drainage basin in which the runoff does not have a surface outfall up to and including the 100-year flood level.
"Closed system"	An enclosed stormwater conveyance system associated with roadways constructed with curb and gutter.
"Commencement of construction"	Issuance of a construction or building permit by Alachua County and commencement of infrastructure or building construction activities.

<i>Term</i>	<i>Definition</i>
“Confining unit”	A stratum or layer of clay, hardpan, organic mucks, or other material that restricts the movement of water below that strata or layer.
“Conservation areas”	Natural resources that, because of their ecological value, uniqueness and particular sensitivity to development activities, require stringent protective measures to sustain their ecological integrity, including wetlands, surface waters, 100-year floodplains, listed species habitat, significant geologic features, and strategic ecosystems.
“Control elevation”	The lowest elevation at which water can be released through a control device.
“Critical duration”	The duration of a specific storm event (i.e., 100-year storm) which creates the largest volume or highest rate of net stormwater runoff (post-development runoff less pre-development runoff) for typical durations up through and including the 10-day duration event (1-hour, 2-hour, 4-hour, 8-hour, 24-hour, 3-day, 7-day and 10-day events). The critical duration is determined by comparing various durations of the specified storm and calculating the peak rate and volume of runoff for each. The duration resulting in the highest peak rate or largest total volume is the "critical-duration" storm.
“Detention”	The collection and temporary storage of stormwater in such a manner as to provide for treatment through physical, chemical, or biological processes with subsequent gradual release of the stormwater.
“Developed area”	That portion of a plot or parcel upon which a building, structure, pavement, gravel, landscaping or other improvements have been placed
“Development”	Any new subdivision or expansion of an existing subdivision, or any new residential, commercial, industrial, institutional or mixed use project, or expansion of such an existing project, where approval is required by the Development Review Committee and/or the Board of County Commissioners.
“Development activity”	Any dredging, filling, excavation, construction of new structures, expansion of existing structures, installation of utilities, roads, personal wireless service facilities, stormwater management systems, septic tanks, bulkheading, land clearing, tree cutting, mechanized vegetation removal and the disposal of solid or liquid waste.



<i>Term</i>	<i>Definition</i>
“Development order”	Any order granting, denying, or granting with conditions a building permit, construction permit, rezoning, subdivision approval, special use permit, special exception, variance, or any other official action by Alachua County having the effect of permitting the development of land.
“Development order, final”	The approval by the county of a proposal containing a specific plan for development, including the densities and intensities of the proposed development. It includes the final approval given by the development review committee (DRC) in accordance with the requirements of the land development regulations or other permits such as excavation permits which have an impact on one or more public facilities that are subject to concurrency.
“Directly connected impervious area,” or “DCIA”	The area covered by a building, impermeable pavement, and/or other impervious surfaces, which drains directly into the conveyance without first flowing across sufficient permeable vegetated land area to allow for infiltration of runoff.
“Discharge”	To allow or cause water to flow to receiving waters or off-site properties.
“Drainage structure”	Culverts, storm drains, and stormwater retention or detention ponds with side slopes that must be stabilized by artificial means.
“Environmental quality”	The character or degree of excellence or degradation in the total essential natural resources of the area as measured by the findings and standards of the physical, natural, and social sciences, the arts and technology, and the quantitative guidelines of federal, state and county governments.
“Event Mean Concentration” (EMC)	A flow-weighted average concentration of pollutants in stormwater. It is defined as the total pollution load mass divided by the total runoff volume for a storm event.
“Excavation”	The removal and transport of earth materials (sometimes referred to as "borrow" activities). This definition excludes commercial mining operations (such as limerock and sand mining operations), excavation associated with construction of storm water management facilities,

<i>Term</i>	<i>Definition</i>
	excavation activities governed by the Alachua County Subdivision Regulations, and excavation associated with sod farming and removal activities, and tree farming activities
“Florida-friendly Landscaping™ ”	Landscaping that is designed in accordance with the principles of Florida-friendly landscaping™ program including planting the right plant in the right place, efficient watering, appropriate fertilization, mulching, attraction of wildlife, responsible management of yard pests, recycling yard waste, reduction of stormwater runoff, and waterfront protection. Additional components of Florida-friendly landscaping™ include planning and design, soil analysis, the use of solid waste compost, practical use of turf, and proper maintenance.
“Florida-friendly fertilizer”	Fertilizers that contain low or no phosphorus, at least 30% slow release nitrogen, meet the requirements in Chapter 5E-1.003, F.A.C., and are applied by a homeowner or a Commercial Fertilizer Applicator certified pursuant to Section 482.1562, F.S.
“Filtration system”	A stormwater BMP such as Biofiltration or Up-flow filters that incorporate suitable fine textured, engineered media that are effective in the removal of stormwater pollutants, especially nutrients
“Geologic features”	A prominent or conspicuous characteristic of earth materials in the landscape. In Alachua County, prominent geologic features include sinkholes, caves, stream bluffs, escarpments, outcroppings, and springs.
Greenfield Development	New development that occurs on lands that have not previously been developed. Such lands range from those with a variety of natural features and resources to cleared agricultural lands.
“Green roof”	A roof of a building that is partially or completely covered with vegetation and a growing medium, planted over a waterproofing membrane. It may also include additional layers such as a root barrier and drainage and irrigation systems.
“Groundcover”	Low growing plants planted in such a manner as to form a continuous cover over the ground, such as liriopse, low growing varieties of honeysuckle, confederate jasmine, English ivy or like materials.
“Ground water”	Water occurring beneath the surface of the ground or in the zone of saturation, whether or not flowing through known or definite channels.

<i>Term</i>	<i>Definition</i>
“High aquifer recharge areas”	Those areas where stream-to-sink surface water basins occur, and those areas where the Floridan Aquifer system is vulnerable or highly vulnerable as depicted in the Alachua County Floridan Aquifer High Recharge Area Map adopted in the Alachua County Comprehensive Plan.
“Hydrologic Unit Code” or “HUC”	The hydrologic cataloging unit assigned to a geographic area representing a surface drainage basin.
Impaired Water	A water body or water body segment that does not meet its applicable water quality standards as set forth in Chapters 62-302 and 62-4, F.A.C., as determined by the methodology in Part IV of Chapter 62-303, F.A.C., due in whole or in part to discharges of pollutants from point or nonpoint sources.
“Impervious surfaces”	Land surfaces that do not allow, or minimally allow, the penetration of water; included as examples are building roofs, normal concrete and asphalt surfaces, and some fine grained or compacted soils.
“Karst”	Landforms that have been modified by dissolution of soluble rock (limestone or dolostones), and which may be characterized by sinkholes, sinking streams, closed depressions, subterranean drainage, and caves.
“Littoral zone”	That portion of a wet detention system that is designed to contain rooted aquatic plants.
“Low Impact Design”	An approach to land development and stormwater management that preserves and protects natural resource systems and water resources using various site planning and stormwater management approaches and technologies to simultaneously conserve and protect natural resource systems and to reduce the average annual stormwater pollutant loading discharged off-site. The approach uses site planning to minimize runoff and a suite of engineered small-scale hydrologic controls distributed throughout the site and integrated as a BMP Treatment Train to replicate the natural hydrologic functioning of the landscape through infiltrating, filtering, storing, evaporating, and detaining runoff close to its source..
“Native vegetation”	Vegetation occurring naturally in the north central Florida region without the influence of humans. Native vegetation is a comprehensive

<i>Term</i>	<i>Definition</i>
	term that encompasses all plant life, including groundcover, grasses, herbs, vines, shrubs and trees that, based on current knowledge, are known to have been present regionally before the time of documented European contact (about 1500 A.D.).
“Net improvement”	The performance standard for treating stormwater to a level where the pollutant loads discharged after development are less than the pollutant loads discharged before development.
Non-Directly Connected Impervious Area	All pervious areas and those portions of impervious areas that flow over at least 10 feet of pervious areas with HSG A or B soils and over at least 20 feet of pervious area for other soil types.
“Non-native vegetation”	Vegetation not natural to the north central Florida region, including prohibited non-native vegetation listed in F.A.C. 62C-52.011, Florida Prohibited Aquatic Plants List, and F.A.C. Rule 5B-57, Florida Noxious Weed List, as well as discouraged non-native vegetation listed in Table 406.08.4.
“Off-line”	The storage of a specified portion of stormwater, such as the required treatment volume, in a manner so that subsequent runoff more than the RTV does not flow into the BMP but bypasses it and goes into the flood control component of the stormwater management system.
“On-line”	A flow-through retention or detention BMP with an inflow and an outflow that provides stormwater treatment and flood control within the flow path of runoff.
”Open Drainage Basin”	Any drainage basin not meeting the definition of a closed drainage basin.
“Open space”	Any natural, recreational, or common open areas, either publicly or privately owned, set aside, dedicated, designated, or reserved for the private use or enjoyment of owners or occupants of land adjoining such open space, or for the public at large.
“Open space, common”	All open space, natural areas, and recreational areas which are within the part of a development designed and intended to be used in common by the owners, residents, or tenants of the development.
“Operate” or “operation”	To cause or to allow a stormwater management system to function as designed and permitted.

<i>Term</i>	<i>Definition</i>
“Paved ground surface area”	Any paved ground surface area (excepting public rights-of-way) used for driving, parking, storing or displaying of vehicles, boats, trailers and mobile homes, including new and used car lots and other open-lot uses. Parking structures, covered drive-in parking areas to the drip line of the covering or garages shall not be considered as paved ground surface areas.
“Pre-development”	Land use, hydrologic conditions, and pollutant loading existing prior to conducting proposed development activities.
“Post-development”	Land use, hydrologic conditions, and pollutant loading existing after proposed development activities are completed.
“Permanent pool”	That portion of a wet detention pond that holds water between the normal water level and the top of the anoxic zone excluding any water volume claimed as wet detention bleed-down volume.
“Permeable Surface”	Land and surfaces that are capable of being permeated, especially by liquids
“Project area”	The area being modified or altered in conjunction with an activity requiring a permit.
Redevelopment	Any construction or improvement performed on sites where the existing site’s impervious area exceeds 40 percent.
“Registered professional”	A professional registered or licensed by and in the State of Florida and who possesses the expertise and experience necessary for the competent preparation, submittal and certification of documents and materials, and performing other services required in support of permitting, constructing, altering, inspecting, and operating a proposed or existing activity regulated under Part IV of Chapter 373, F.S. Examples of registered professionals, authorized pursuant to Chapter 455, F.S., and the respective practice acts by which they are regulated, are professional engineers licensed under Chapter 471, F.S., professional landscape architects licensed under Chapter 481, F.S., professional surveyors and mappers under Chapter 472, F.S., and professional geologists licensed under Chapter 492, F.S.

<i>Term</i>	<i>Definition</i>
“Retention”	A stormwater treatment system designed to prevent the discharge of a given volume of stormwater runoff, such as the RTV, into surface waters by complete on-site storage of that volume.
“Seasonal high ground water table” (SHGWT)	The zone of water saturated soil at the highest average depth during the wettest season of the year during periods of normal rainfall, based upon site-specific factors described in Appendix C of this Manual.
“Semi-impervious”	Land surfaces that partially restrict the penetration of water; included as examples are pervious pavements, lime rock, and other compacted materials.
“Significant adverse impact (upon a natural resource)”	Direct contamination, alteration, or destruction, or that which contributes to the contamination, alteration, or destruction of a natural resource, or portion thereof, to the degree that its environmental benefits are or will be eliminated, reduced or impaired, such that the activity will cause long term negative impacts on the natural resource.
“Significant geologic features”	Geologic features such as sinkholes, springs, caves, stream bluffs, escarpments, outcroppings, and other karst features.
“Sinkhole”	A funnel-shaped depression in the land surface, generally in a limestone region, caused by solution processes and often resulting in connection(s) with subterranean passages and ground water systems.
“Soil Survey”	A document prepared by the U.S. Natural Resources Conservation Service that provides soil maps and interpretations useful for guiding decisions about soil selection, use, and management.
“Spring”	A point where ground water emerges onto the earth's surface, including under any surface water of the state, as well as seeps. The term spring shall include karst windows, which are depression openings that reveal portions of a subterranean flow or the unroofed portion of a cave. It shall also include spring runs, whose flow is predominantly composed of spring discharge.
“Springshed or Spring Recharge Basin”	Those areas within ground and surface water basins that contribute to the discharge of a spring.

<i>Term</i>	<i>Definition</i>
"Stormwater"	The flow of water that results from, and which occurs, immediately following a rainfall event.
"Stormwater harvesting"	The beneficial use of treated stormwater to reduce the volume of stormwater and the associated pollutant load discharged from a stormwater treatment system, but specifically does not include reclaimed water as defined in Chapter 62-610, F.A.C.
"Stormwater management system"	A system which is designed and constructed or implemented to control discharges which are necessitated by rainfall events, incorporating methods to collect, convey, store, absorb, inhibit, treat, use, or reuse water to prevent or reduce flooding, overdrainage, environmental degradation, and water pollution or otherwise affect the quantity and quality of discharges from the system.
"Stormwater treatment system"	A system which is designed and constructed or implemented to reduce the pollutant loadings in stormwater discharges by incorporating methods to collect, convey, store, absorb, treat, use, or reuse stormwater.
"Surface waters"	Rivers, streams, creeks, springs, lakes, ponds, intermittent water courses and associated wetlands that hold or transport water on the ground surface.
"Swale"	<p>A manmade trench which:</p> <ul style="list-style-type: none"> <li>(1) Has a top width to depth ratio of the cross-section equal to or greater than 6:1, or side slopes equal to or flatter than 3 feet horizontal to 1-foot vertical;</li> <li>(2) Contains contiguous areas of standing or flowing water only following a rainfall event;</li> <li>(3) Is planted with or has stabilized vegetation suitable for soil stabilization, stormwater treatment, and nutrient uptake; and</li> <li>(4) Is designed to take into account the soil erodibility, soil percolation, slope, slope length, and drainage area so as to prevent erosion and reduce pollutant concentration of any discharge."</li> </ul>
"Total Maximum Daily Load" (TMDL)	The maximum allowable average annual loading to an impaired water body that will allow the water body to meet its applicable water quality standards. A TMDL is adopted by FDEP and represents the sum of the individual wasteload allocations for point sources, the load

<i>Term</i>	<i>Definition</i>
	allocations for nonpoint sources, and natural background for an impaired water body or WBID. A TMDL includes either an implicit or explicit margin of safety or a consideration of seasonal variations. (Chapter 62-302.200, F.A.C).
“Tailwater”	The receiving water elevation (or pressure) at the final discharge point of the stormwater management system.
“Tree canopy”	The area of the property that contains coverage by trees and consists of the total crown spreads or drip-lines of all trees existing on-site.
Water Body Identification Number or WBID	A water body assessment unit representing a relatively homogenous and hydrologically distinct segment of a major surface water body. Each assessment unit is represented by a unique waterbody identifier (WBID number) and is characterized by waterbody type (including rivers/streams, lakes, estuaries, coastal waters, and beaches) and a waterbody class.
“Watercourse”	A river, creek, stream, channel or other topographic feature in, on, through, or over which water flows at least periodically.
“Watershed”	The land area that contributes water or stormwater to a surface water.
“Water quality standards” or “State water quality standards”	Those standards set forth in Chapters <a href="#">62-4</a> , <a href="#">62-302</a> , <a href="#">62-520</a> , and <a href="#">62-550</a> , F.A.C., including the antidegradation provisions of paragraphs 62-4.242(1)(a) and (b), F.A.C., subsections 62-4.242(2) and (3), F.A.C., and Rule 62-302.300, F.A.C.
“Waters of the state”	Those waters defined in Section 403.031(13), F.S.
“Well”	Any excavation that is drilled, cored, bored, washed, driven, dug, jetted, or otherwise constructed when the intended use of such excavation is to conduct ground water from an aquifer or aquifer system to the surface by pumping or natural flow, to conduct waters or other liquids from the surface into any area beneath the surface of land or water by pumping or natural flow, or to monitor the characteristics of ground water within an aquifer system(s). For the purposes of this



<i>Term</i>	<i>Definition</i>
	chapter, geotechnical borings greater than 20 feet in depth shall be included in the definition of "well."
"Wet detention"	The collection and temporary storage of stormwater in a permanently wet impoundment in such a manner as to provide for treatment through physical, chemical, and biological processes with subsequent gradual release of the stormwater.
"Wetlands"	<p>Those areas that are inundated or saturated by surface water or ground water at a frequency and a duration sufficient to support, and under normal circumstances do support, a prevalence of vegetation typically adapted for life in saturated soils.</p> <p>Soils present in wetlands generally are classified as hydric or alluvial, or possess characteristics that are associated with reducing soil conditions. The prevalent vegetation in wetlands generally consists of facultative or obligate hydrophytic macrophytes that are typically adapted to areas having soil conditions described above. These species, due to morphological, physiological, or reproductive adaptations, can grow, reproduce or persist in aquatic environments or anaerobic soil conditions. The landward extent of wetlands is delineated pursuant to Rules 62-340.100 through 62-340.550, F.A.C., as ratified by Section 373.4211, F.S.</p>

# CHAPTER 2. EVALUATING AND MASTER PLANNING A SITE

## 2.1. Overview

This chapter provides a brief overview of the changes in [stormwater](#) characteristics that accompany the urbanization process; the goals of stormwater management; and a discussion of stormwater pollutants and removal mechanisms. The chapter also includes a discussion of essential site planning requirements and introduces [Low Impact Design](#) concepts, strategies, and techniques that provide new tools for stormwater management.

## 2.2. Changes in Stormwater Characteristics from Urban Development

### 2.2.1. Changes in Urban Hydrology

Urban development changes the physical characteristics of the natural landscape and creates changes in land use and human activities. These can cause a litany of adverse impacts to general land conditions, watershed hydrology and pollutant loading, surface and ground water quality, and natural systems, such as freshwater wetlands and floodplains.

[Development](#) and [redevelopment](#) activities remove natural vegetation, compact soils, and add [impervious surfaces](#) such as roads, parking areas, sidewalks, and rooftops. These changes reduce, disrupt, or eliminate native vegetation, upper soil layers, shallow depressions, and natural drainage patterns that intercept, evaporate, store, slowly convey, and infiltrate stormwater. As urbanization occurs, the areas that contribute stormwater to receiving waters increase while the areas that naturally manage stormwater diminish.

**Figure 2.1. Stormwater flow changes associated with urbanization.**

The blue line represents the pre-development hydrograph and the brown line is the post-development hydrograph. (Source: U.S. Environmental Protection Agency)

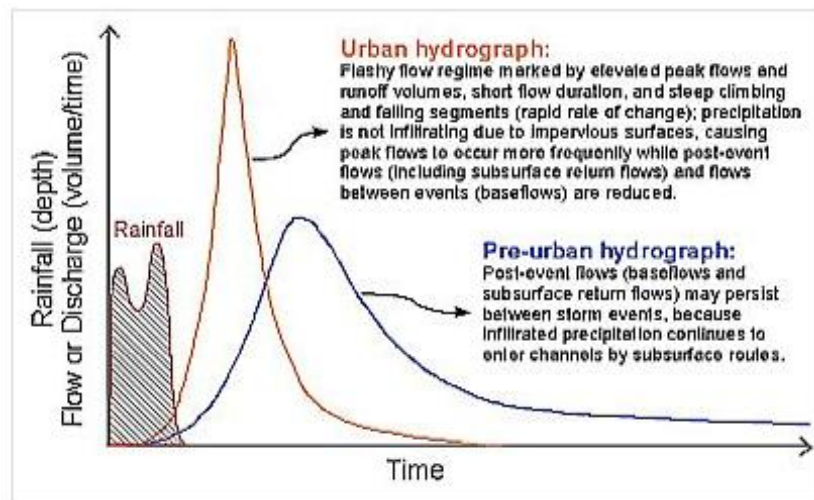

The hydrologic and hydraulic effects of these activities include reduced infiltration and ground water recharge, increased peak discharge rate and volume of stormwater runoff, and increased erosion and sedimentation.

These common consequences of urban development lead to lowering of ground water tables, altered stream flows; altered wetland and lake water levels; and an increased magnitude and frequency of flooding. Figures 2.1. and 2.2 summarize the changes in hydrology associated with the urbanization process.

**Figure 2.2. How Impervious Cover Affects the Water Cycle**

(Source: U.S. Environmental Protection Agency)

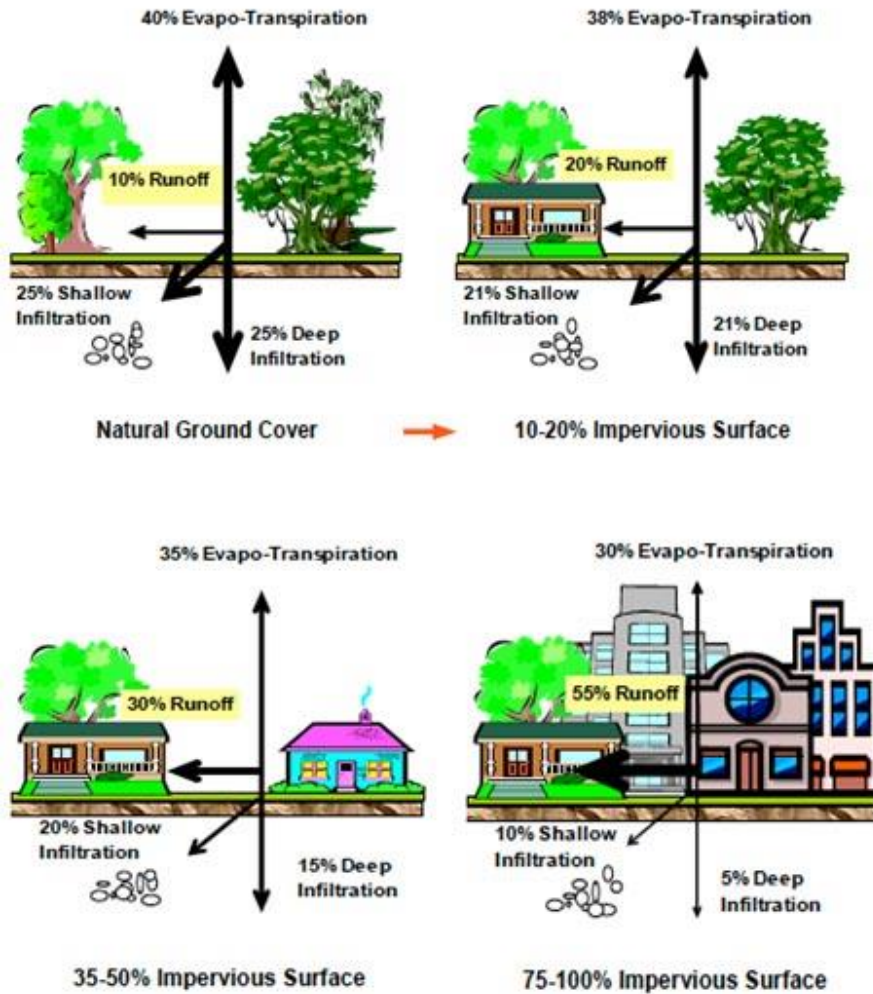

**2.2.2. Stormwater Pollutants and Removal Processes**

Urban development degrades water quality by accelerating eutrophication in surface waters receiving runoff and can increase nutrients in ground waters. The reduction in pervious surface and vegetation in the developed landscape removes natural filtration mechanisms and increases pollutant loads discharged into receiving waters. Fertilizers, pesticides, oils and greases, and other pollutants characteristic of urban land uses are flushed from the watershed during storms becoming trapped in stormwater.

An understanding of what pollutants are likely to be in the stormwater, the processes needed to remove them, and the BMPs available to provide those processes can help ensure that effective stormwater treatment is provided. The most common pollutants in stormwater are sediment, nutrients (nitrogen and phosphorus), heavy metals (zinc, nickel, lead, chromium, cadmium, and copper), pathogenic bacteria, pesticides, and organic pollutants (gasoline and oils).

In Florida, excess nutrients are the greatest water quality issue facing our surface and ground waters. In fact, many water bodies are not meeting their nutrient criteria. The FDEP adopts Total Maximum Daily Loads (TMDLs) that sets a watershed-based pollutant loading cap for

these “[impaired waters](#).” This prevents new pollutant loadings to the water body and requires existing pollutant loading sources within the watershed to reduce their loads. There are many sources of nutrients. Nutrients are applied to our farms, lawns and public landscaped spaces as fertilizers, and are discharged to the ground water from septic tanks. Nitrogen from atmospheric deposition and vehicular tailpipes is deposited on parking lots and roads. Then washed off by rainfall.

*Phosphorus* is often the growth limiting nutrient in surface water, so any increase in its concentration is likely to result in increased growth of algae and other plants. The clarity of the water is decreased, and when algae die off decomposing bacteria can deplete oxygen levels in the water, harming other aquatic life.

Native soils in north Florida often have very high levels of mineral phosphorus. Consequently, plants need little or no phosphorous application through fertilizers. Any excess applied to our landscapes is carried away by runoff from the next rain or infiltrated into the ground water, raising phosphorus levels in our natural water bodies. Phosphorus levels in soils and leaf tissues can easily be determined by testing at local Cooperative Extension Service offices.

Phosphorus occurs in inorganic or organic forms, dominated by inorganic orthophosphates. In water, it can also be classified as either dissolved or in particulate form. Both inorganic and organic forms can found as dissolved and suspended particulates. The particulates include phosphorus adsorbed to suspended sediment, organically bound particles, or phosphorus precipitated aluminum, iron or calcium.

Accordingly, there are three primary mechanisms to remove phosphorus from stormwater.

- Sedimentation: Most of the phosphate is bound to particulates and can be mechanically removed by sedimentation and infiltration. The effectiveness depends on the particle sizes and densities.
- Removal by plants: Much of the small fraction of phosphorus that is naturally soluble is bioavailable. Additionally, some particulate-bound phosphorus can become bioavailable when broken down by bacteria. Long contact times in wet detention ponds and wetlands facilitate its removal from stormwater.
- The third mechanism is precipitation from solution. Soil or man-made media containing calcium, iron, or aluminum or cement can react to form a precipitate with phosphorus.

Theoretically dissolved phosphorus can be removed by any BMP that employs vegetative growth or passage through appropriate soil or media, and particulate phosphorus can be removed by sedimentation and infiltration. However, the amount removed varies considerably in [stormwater treatment systems](#). One complication is that a large proportion of particulate phosphorus may be stored in sediment. Decomposing plant material can also release formerly dissolved phosphorus again into the water, and can cause treatment ponds and wetlands to eventually act as phosphorus source rather than a sink. Periodic sediment removal and harvesting of plant growth is necessary to maintain long-term removal effectiveness.

The solubility of phosphorus is not a constant. The pH is an important factor, with 6.5 corresponding to maximum solubility. As pH increases more phosphorus precipitates with calcium, but aluminum and iron precipitates are more common in acidic soil. Higher pH levels correspond to decreased oxidation-reduction potential of suspended particles, further reducing their sorption capacity for phosphorus. Temperature changes and anaerobic conditions can



also change removal effectiveness. Phosphorus removal is therefore highly variable, and can be site specific.

*Nitrogen* exists in several forms in the environment: ammonia ( $\text{NH}_3$ ), nitrite ( $\text{NO}_2$ ), nitrate ( $\text{NO}_3$ ), or as nitrogen gas ( $\text{H}_2$ ). Fertilizers and decomposing organic matter contain ammonia, which is broken down by microorganisms in the soil. If oxygen is available (aerobic conditions), ammonia will be converted to nitrite, and then into nitrate. This typically occurs in shallow water bodies as well as in soil. Nitrate is very soluble in water and is not removed by sedimentation or sorption mechanism, so excess nitrates can easily enter [ground water](#).

Nitrates are harmless in naturally occurring amounts, but high levels can cause health problems for babies. They should not ingest water or infant formula made with water with  $\text{NO}_3\text{-N}$  levels exceeding 10 mg/l. Few places have nitrates high enough to cause health concerns, but many of Alachua County's [springs](#) have increasing nitrates, and the lower Santa Fe River is impaired by high  $\text{NO}_3$  levels. In some springs  $\text{NO}_3\text{-N}$  has increased from naturally occurring levels of < 0.1 mg/l to more than 5 mg/l. While these levels are not likely to cause health concerns, they can cause spring water to become cloudy with increased plant growth and lead to algal blooms in water bodies.



*Low nitrate levels in ground water result in clear springs*

Abnormally high levels can come from septic systems and municipal and agricultural wastewater, as well as overuse of fertilizers. Additionally, monitoring of septic tanks in several areas of Florida, along with recent monitoring of [stormwater retention systems](#) in Alachua and Marion County, has demonstrated the importance of soil characteristics in and beneath retention BMPs in reducing nitrate formation and movement into the ground water.

Nitrate leaching into ground water can be lessened in two ways. Plants take in nitrate as a requirement for their growth, so it can be removed in any vegetated area. It is most effective where there is vigorous plant growth, such as in wetlands and enhanced stormwater ponds. However, if the resulting plant growth is not removed, it will release nutrients as it decomposes and the previously absorbed nitrogen will re-enter the water cycle.

The second way nitrate is removed is when the Nitrogen Cycle is promoted in the design of the retention system. This is accomplished by ensuring the soil characteristics promote soil microbial mechanisms of Ammonification, Nitrification, and Denitrification. Key soil characteristics include high soil moisture, low dissolved oxygen concentrations, high clay content, and high Cation Exchange Capacity. For example, fine-textured soils retain moisture,

**Figure 2.3. The Nitrogen Cycle transforms nitrogen into nitrogen gas**

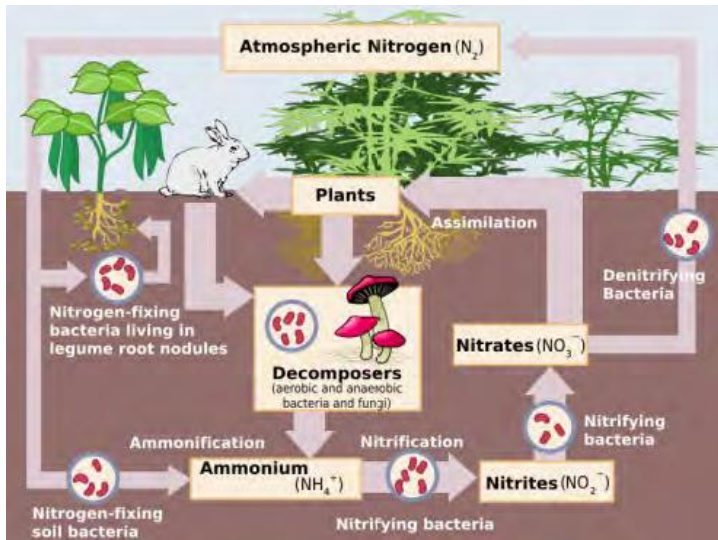

have a higher CEC, and reduce oxygen transport into the subsurface. The Karstic sandy soils typically found in much of western Alachua County do not have these types of soil characteristics leading to nitrate formation and movement into the ground water and springs. Soil amendments such as [Biosorption Activated Media \(BAM\)](#) can be used to create the proper soil conditions to promote the Nitrogen Cycle and reduce nitrate loads discharged from retention BMPs into the ground water. Alternatively, retention basins can be lined and the stormwater harvested for irrigation.

*Metals* – Stormwater is the source of 80-95% of heavy metals in Florida's surface waters. Zinc, cadmium, copper and nickel enter stormwater from our cars from degradation of tires, engine parts and brake linings along with motor oils, grease, and other lubricants. They are deposited on roadways as they leak or wear down, and are washed off by stormwater. Insecticides and fungicides also may contain copper and cadmium. Many metals are particulate in nature and are effectively removed by sedimentation and settling. Other metals are in dissolved form and can be removed by wetland vegetation. Heavy metals can also be removed through sorption by filtering stormwater through certain types of vegetative mats with high lignin content, such as alfalfa or aspen fibers (Han, 1999).

*Organic pollutants* such as oil, gasoline, and other hydrocarbons have a high affinity for soil and mulches and are usually removed and biodegraded during infiltration. Sunlight and bacteria in standing water bodies also can degrade hydrocarbons.

See [Section 5.2](#) for additional information on stormwater treatment fundamentals and mechanisms.

## 2.3. Goals of Stormwater Management

### 2.3.1. General goals of stormwater management

The ultimate stormwater management goal is to maintain the pre-development stormwater characteristics of a site or watershed after development ([Section 62-40.431\(2\)](#), F.A.C.). More generally, the goals of stormwater management are to minimize the adverse effects of urban development on communities, watersheds, water bodies, wetlands, floodplains and other natural systems. These goals also are applied to [redevelopment](#) situations so that existing stormwater conditions are appropriately improved with reconstruction. More specifically, these goals include:

Reducing pollutant concentrations and loadings as needed to ensure that discharges do not cause or contribute to violations of [State water quality standards](#).

Preventing or reducing on-site and off-site flooding.

Maintaining or restoring the hydrologic integrity of wetlands and aquatic habitats.



Maintaining and promoting ground water recharge.  
Minimizing erosion and sedimentation.  
Promoting the reuse of rainfall and stormwater

### 2.3.1. Alachua County Comprehensive Plan - Stormwater Management Goals

**This section of the Manual applies only to projects within unincorporated Alachua County. Each of the Municipalities in the County have adopted Comprehensive Plans that apply to projects within their boundaries. If your project is within a Municipality, please obtain the appropriate Comprehensive Plan and Land Development Codes that apply to your project.**

The [Alachua County Comprehensive Plan](#) is a document developed primarily to guide growth and development within the County through policy initiatives. The applicable Policies, Goals and Objectives of the Comprehensive Plan were used as the foundation to the purpose and intent of the Stormwater Management Manual.

The goal of the Conservation and Open Space Element of the Comprehensive Plan is to conserve, manage, and restore or enhance the natural and human-related resources of Alachua County to ensure long-term environmental quality for the future. Objectives and Policies in this section set forth requirements to establish environmental conservation as a priority in all decision-making for Alachua County. Specific Objectives and Policies set forth resource protection standards for soils, slopes, geologic resources, strategic ecosystems, ground waters, springs, and surface waters. Low Impact Design (LID), “green” building, and other sustainable stormwater techniques are specifically recognized as tools to achieve these goals. Innovative techniques and public education are encouraged.

The Surface Water Management Element of the Comprehensive Plan addresses the County’s broad approach to watershed planning and surface water management, and states the County’s intent to manage stormwater flow in the urban environment to help reduce the impact on natural features. A goal for future watershed planning is to offset existing stormwater deficiencies in the County. “Natural” design alternatives for stormwater treatment are encouraged.

The Stormwater Management Element of the Comprehensive Plan establishes Objectives and Policy to protect natural drainage features and the quality of waters and protect new and existing developments with adopted levels of service for floodplain management, stormwater quantity, and stormwater quality. The Element establishes minimum Levels of Service (LOS) and specific policy requirements to ensure that stormwater management on all new development and redevelopment achieve the adopted LOS. The Element promotes LID techniques to provide better protection of surface and ground waters.

## 2.4. Introduction to Stormwater Management

[Stormwater management systems](#) are required to mitigate the stormwater quantity and quality changes that accompany urban development. Stormwater treatment systems are those components of a stormwater management system constructed to control pollutant loads. Stormwater treatment systems use [best management practices \(BMPs\)](#) that can be categorized into two basic categories:

(a) Nonstructural BMPs (AKA source controls). These BMPs are used for pollution prevention to minimize pollutants getting into stormwater or to minimize stormwater volume. They include [Site Planning BMPs](#) such as preserving vegetation, clustering development, minimizing total imperviousness or directly connected impervious areas. They also include [Source Control](#)

[BMPs](#) such as minimizing clearing, minimizing soil compaction, and using [Florida-friendly landscapes](#) and [fertilizers](#). All of these nonstructural BMPs fall under the umbrella term known as “[Low Impact Design](#)” (LID) that is discussed later in this Chapter.

(b) Structural BMPs. Structural BMPs are used to mitigate the changes in stormwater characteristics associated with land development and urbanization. There are three major types of structural BMPs: retention BMPs, detention BMPs, and filtration BMPs.

- [Retention BMPs](#) are infiltration-based practices – the stormwater treatment volume is not discharged directly to surface waters but is “retained on-site” through percolation into the soil, evaporation, and evapotranspiration. Infiltration BMPs include retention basins, exfiltration trenches, swales, vegetated natural buffers, and pervious pavements,
- [Detention BMPs](#) are those that detain stormwater and discharge it off-site at a specified rate, usually the pre-development peak discharge rate. The most common type of detention BMP in Florida is a wet detention system that has a permanent pool of water.
- [Filtration BMPs](#) typically are used on the bottom of retention areas and with detention systems in which the discharge structures incorporate pollutant removal media, often a [Biosorption Activated Media](#), within a filtration system. Filtration systems are more maintenance intensive and are generally used in special circumstances where more traditional retention and detention BMPs do not achieve the stormwater treatment goals for a site or project.

[Table 6.1](#) lists the nonstructural and structural BMPs incorporated into this Manual. Each of these BMPs is discussed and described in more detail in [Section 6.1](#) (Site Planning BMPs), [Section 6.2](#) (Source Control BMPs), or [Sections 6.3 through 6.16](#) (Structural BMPs).

## 2.5. Introduction to Low Impact Design

### 2.5.1. What is “Low Impact Design” (LID)

LID is a stormwater and land use management strategy that strives to mimic pre-disturbance hydrologic processes of infiltration, filtration, storage, evaporation, and transpiration by emphasizing conservation, use of on-site natural features, site planning, and distributed stormwater management practices that are integrated into a project’s design, especially it’s landscaping and open space.

The goals of LID stormwater management include:

**Achieve multiple objectives** – Comprehensive stormwater management helps achieve multiple objectives such as: managing peak discharge rates and total discharge volume; providing effective stormwater treatment to minimize pollutant loadings; maintaining or improving the hydrologic regime at a site; and retaining or [harvesting stormwater](#) on-site for non-potable purposes. LID also promotes integrating stormwater systems into the landscaping and open space of a site creating more attractive and diverse systems.

**Preserve or restore natural features and resources** – The conservation or restoration of natural features such as floodplains, soils, and vegetation helps to retain or restore hydrologic functions thereby achieving the multiple objectives above.

**Minimize soil compaction** – Soil compaction disturbs native soil structure, reduces infiltration rates, and limits root growth and plant survival.

**Reduce and disconnect impervious surfaces** – By minimizing [impervious surfaces](#), especially [directly connected impervious surfaces](#), more rainfall can infiltrate into the ground and less stormwater volume and pollutant loading are generated.

**Manage stormwater close to the source** - Using source controls to minimize the generation of stormwater or pollutants that can get into stormwater needs to be first step in managing stormwater.

**Use a [BMP Treatment Train](#) approach** – Effective stormwater management requires a comprehensive approach that incorporates source controls with multiple structural stormwater BMPs (retention, detention, and filtration) often integrated into the landscaping to create an efficient stormwater management system.

Successful adoption of LID stormwater management requires a fundamental shift in thinking from the traditional “collect, concentrate, convey, centralize and control” approach to a new stormwater management mantra of “retain, detain, recharge, filter and use”. Unlike conventional stormwater systems, which typically control and treat runoff using a single engineered stormwater BMP located at the “bottom of the hill,” LID systems are designed to promote volume attenuation and treatment at or near the source. LID systems use a suite of stormwater BMPs – Site Planning BMPs, Source Control BMPs, and Structural BMPs such as retention, detention, infiltration, treatment and harvesting mechanisms – that are integrated into a project site to function as a [“BMP Treatment Train.”](#)

LID practices facilitate on-site infiltration by preserving [pervious surfaces](#), limiting the total area of [impervious surfaces](#), and [disconnecting impervious surfaces](#). The following site design objectives are key to achieving the County’s stormwater hydrology and pollutant load reduction goals:

Conservation Measures - Preserve or conserve existing site features and assets that facilitate natural hydrologic function.

- Maximize retention and protection of native forest cover, vegetation and wetlands and replant trees and other vegetation to intercept, evaporate, and transpire precipitation.
- Preserve permeable, native soil, and enhance disturbed soils to store and infiltrate stormwater.
- Retain and incorporate topographic site features that slow, store, and infiltrate stormwater.
- Retain and incorporate natural stormwater management features and patterns.
- Minimize site disturbance and compaction of soils through low-impact clearing, grading, and construction measures.

Site Planning and Minimization Techniques - Minimize generation of runoff and pollutants from your project as close to the source as possible.

- Use a multidisciplinary approach that includes planners, engineers, landscape architects, and architects at the initial phases of the project.
- Locate buildings away from critical areas and soils that provide effective infiltration.
- Reduce hard surfaces, total impervious surface area, minimize directly connected impervious areas, increase retention of native vegetation, and plant native trees.

Distributed and Integrated Management Practices

- Manage stormwater as close to its origin as possible by using small scale, distributed hydrologic controls.
- Create a hydrologically rough landscape that slows storm flows.
- Increase reliability of the stormwater management system by providing multiple or redundant LID flow control practices.
- Integrate stormwater controls into the development design and use the controls as amenities to create a multifunctional landscape.
- Reduce the reliance on traditional conveyance and pond technologies.

Low Impact Construction Techniques - Clearing, grading, and construction measures that minimize site disturbance and promote LID function:

- Minimize the amount of area cleared.
- Clear selectively to protect trees and other vegetation.
- Use smaller and lighter construction equipment where possible.
- Keep heavy equipment outside of the drip line of preserved trees.
- Minimize grading and importing of fill (e.g., through use of stemwall construction).
- Keep heavy equipment off soils where infiltration-dependent stormwater practices will be used.
- Designate storage areas for construction equipment and materials

Maintenance and Education

- Develop reliable and long-term maintenance programs to provide clear and enforceable standards.
- Educate owners of LID projects, landscape management professionals, and other interested parties on the operation and maintenance of LID systems.
- Protect LID systems by promoting community participation.

A fundamental premise of LID is that the more closely an engineered stormwater system mimics a site's [pre-development](#) hydrologic characteristics, the better it will perform in terms of meeting both volume control and treatment goals for the project. This means LID projects should strive to have the same conditions (or better, if a site has already been degraded) for total and peak stormwater runoff volumes, runoff conveyance patterns, and infiltration and treatment capacity as were present before development. LID project designs typically employ a combination of innovative, conventional, non-structural and structural engineered designs to accomplish these goals. Note that although LID techniques are often decentralized within a site or parcel, they are not disconnected but are integrated into a BMP Treatment Train.

Typically, LID practices will not completely replace more conventional "bottom-of-the-hill" stormwater management practices, but can be used to complement these practices and to ensure that the entire stormwater management system meets the Alachua County water resources objectives. Combining conventional and LID stormwater management practices can reduce the area devoted solely to stormwater management and allow more efficient use of the development site.

### **2.5.2. Advantages of LID**

Why might LID – from a single BMP to an LID master plan – be considered a superior alternative to conventional design? Quite simply, it depends on the interests of the party or person posing the question, but the evidence from a growing field of LID practice suggests that

with the essential ingredients of early planning, commitment, and creativity, LID strategies can lead to net benefits for all parties involved.

For the developer, the LID reward might be a direct monetary benefit from avoided investments in stormwater infrastructure – or a lot gained via clustering and stormwater management with native hydrologic conditions in mind. For local governments and the general public, the LID reward might be the benefit of protected or enhanced water quality and reduced stress on natural resources that sustain local economies. For the homeowner, the LID reward might be improved property values. Integrating LID strategies as standards of practice in development projects will take time, energy and commitment on the part of developers, builders, county staff, and homeowners, yet the diversity of economic, environmental and social benefits that LID strategies have to offer make them a critical piece of the overall stormwater management strategy in Alachua County.

Despite concern that the assumed or perceived financial costs associated with using LID in [redevelopment](#) projects will drive developers to [greenfield development](#), encouraging sprawl and exacerbating water quality problems, experience is proving that developers are pursuing (and having success with) LID projects in both redevelopment and greenfield projects. Not only are developers with experience in LID continuing to invest in projects in their standard markets despite increasingly strict stormwater standards, but they also are finding that LID can reduce their costs relative to conventional stormwater controls (EcoNorthwest, 2011) The most commonly cited area of cost savings/revenue gains for developers choosing LID over conventional design is in stormwater piping and road infrastructure (conveyance pipes, etc.), landscape investments (e.g., sod area, in-ground irrigation systems), and developable lots (e.g., via clustering and distributed stormwater conveyance and treatment controls, reducing the size of the stormwater pond necessary for treatment.)

In a 2009 article in *Land Development* magazine, local landscape architect and University of Florida faculty member Glenn Acomb describes the LID experience in *Madera*, a 44-acre, 80-lot residential subdivision in the City of Gainesville, Florida. Preservation of existing hydrology, topography and tree canopy were critical elements of the site design. By taking advantage of existing contours of the site to capture and infiltrate stormwater, the site plan resulted in on-site control of the majority (70%) of the site's stormwater runoff; furthermore, this design saved the developer \$40,000 in stormwater infrastructure costs (U.S. HUD, 2005) At the lot level, resource-efficient, LID strategies were integrated to the maximum extent possible, from Energy Star certification to Florida-friendly landscaping™, to shared driveways. Comparing *Madera* "LID" lots to conventional lots, Acomb reports a 7.6% savings in capital costs (about \$1,500 per lot to the developer) and estimates approximately \$1,900 in annual savings per lot for landscape maintenance (to the homeowner) for the *Madera* lots (Acomb, 2004). Pre-development conditions made the site particularly favorable for implementing a broad suite of LID strategies, and *Madera* serves as a model example of LID in new residential development in Alachua County.

Not all monetary costs/benefits of LID stormwater management fall to the developer, however. Occupants of buildings with green roofs, for example, can realize significant energy savings (i.e., reduced operational costs) over the life of the project. Homeowners with rain gardens or lots adjacent to ecologically enhanced stormwater ponds may benefit from increased market value of their homes (particularly as the consumer market for native, low-maintenance landscapes continues to grow.)

ECONorthwest (2011) provides a detailed report on the factors influencing developers' decisions to pursue LID projects, profiling three of the most progressive regions of the U.S. with respect to LID (Montgomery County, MD; Philadelphia, PA; Olympia, WA). Their results indicate a significant (albeit gradual) shift occurring in the market for LID in both redevelopment and greenfield projects. The report highlights the need for creativity and flexibility on the part of the development team to realize the significant economic, environmental and social benefits that LID approaches offer. The full report is available at:

[http://doee.dc.gov/sites/default/files/dc/sites/ddoe/publication/attachments/ECONW\\_Final\\_Report\\_2011-0628.pdf](http://doee.dc.gov/sites/default/files/dc/sites/ddoe/publication/attachments/ECONW_Final_Report_2011-0628.pdf)

For a comparison of traditional and LID development techniques along with a tool to conduct a cost-benefit analysis for your site, consult the Green Values National Stormwater Calculator at <http://greenvalues.cnt.org/national/calculator.php>.

Environmental and ecological rewards from LID include water quality protection/pollution prevention, protection of drinking water supplies via enhanced infiltration and treatment of stormwater runoff, and wildlife and habitat protection and provision.

Many LID applications are valued as social or community amenities. Roadway and median swale/tree box/green street applications often calm traffic (improving public safety) and reduce heat-island effects in urban environments. Mixed-use, clustered communities reduce the need for lengthy commutes from home to work or play (which also translates to a monetary benefit for residents). While difficult to value directly, the aesthetics of LID stormwater features also provide a public amenity.

## 2.6. Site Planning and Design

To effectively use and integrate LID practices into a [stormwater management system](#) requires sites to be evaluated for LID compatibility as early as possible in the planning process. Specific site conditions must be carefully evaluated to determine LID feasibility and to design and construct each LID practice. This manual supports Alachua County's goal of applying the LID concept and design where feasible to enhance existing stormwater management measures and reduce the adverse impacts of land development projects on the County's natural resources.

Assessing a site's natural stormwater management capabilities and resources is a necessary step toward integrating them into the stormwater management system. The site assessment process provides information about current conditions that are essential to implement the site planning and layout activities. Specifically, site assessment should evaluate hydrology, topography, geology, soils, vegetation, wetlands, and water features to identify how stormwater moves through the site before and after development or redevelopment. Projects should be designed and constructed with the objective of preserving and using on-site features to help manage stormwater. Site conditions that need to be evaluated include: What natural features (tree canopy, vegetation, depressions, etc.) intercept and/or capture rain as it falls on the site and return portions of it to the atmosphere via infiltration, evaporation and/or transpiration?

Key site assessment factors that are directly related to the type and design of a BMP Treatment Train for a specific development site include:

- What is the topography of the site and does it promote stormwater drainage away from the site or capture and infiltrate stormwater on-site?



- Is the site adjacent to a [water body](#) or [wetlands](#) and does it have any buffer or riparian zones?
- Does the site discharge to an impaired water body?
- What are the [hydrologic soil groups](#) and distributions on-site, and to what extent do they promote infiltration of rainfall (i.e., what are their infiltration rates)? Is there a “hard pan” in lower soil levels that inhibits infiltration?
- Where and to what extent have soils been modified, disturbed and/or compacted, reducing infiltration rates and promoting runoff generation?
- What is the elevation of the [SHGWT](#) throughout the site and when and how long does it occur?
- Do critical and sensitive areas (wetlands, riparian areas, etc.) that provide capture, uptake, and filtering of pollutants exist on site and have they been protected or disturbed?
- What physical structures (buildings, parking lots, etc.) intercept rainfall and convey it as stormwater to other areas of the site and/or away from the site?
- What [pervious surfaces](#) (natural and structural) allow stormwater to infiltrate to parent soils?
- What [impervious surfaces](#) (natural and structural) prevent infiltration of stormwater and promote runoff?
- What engineered [stormwater treatment systems](#) exist on site and could they be enhanced or retrofitted to improve performance?

A first step in evaluating sites for LID opportunities is to review the Site Planning BMPs and the Source Control BMPs in [Table 6.1](#). Several of these LID BMPs provide direct or indirect stormwater pollutant load reduction credits. Next, complete a thorough assessment of environmental conditions on the site. The Environmental Resources Assessment Checklist (Figure 2.4) can be used for this.

The items on the Checklist can help designers choose appropriate BMPs that protect important resources. For example, in high aquifer recharge areas, infiltration-based BMPs such as retention basins, rain gardens, and permeable pavement systems should always be considered, but the topography of the site (e.g., steep slopes) might constrain their design. For projects in wellfield protection areas or those where spills of hazardous materials are possible, source control of stormwater pollutant loads is an especially important consideration, and infiltration-based treatment BMPs must be designed to avoid inadvertent transfer of contaminants from surface water to ground water.

The environmental assessment is also intended to ensure LID BMPs and strategies are considered as early as possible in the project design. They should never be an afterthought or simple “add-on” to a conventional design. Mechanisms to reduce site disturbance before, during, and after construction are some of the most critical elements of an integrated and effective approach to LID stormwater planning. Opportunities to preserve and promote natural hydrologic functioning of a site are often lost due to conventional development practices such as non-selective site clearing, export of native soils, importing of fill, mass grading, and construction in sensitive areas using heavy machinery. Compacting soils reduces the pore space available for storage and infiltration of stormwater.

Rather than defining the project goals, designing the stormwater system to meet those goals, and then trying to fit LID BMPs into the project, developers and project engineers are encouraged to first define the project goals to be consistent with using LID BMPs, and then plan the entire site and design the entire stormwater management system to use as many LID

principles and BMPs as possible. LID BMPs work well at both the subdivision level and on individual lots as seen in Figures 2.5 and 2.6.

Project planners and design engineers should consider stormwater an asset that can be used to reduce the impact of development projects on water resources. Rather than designing systems to drain stormwater from the site, LID promotes retention, treatment and harvesting of stormwater on-site. To encourage the practice of using stormwater as an asset, Alachua County has included incentives within the [Unified Land Development Code](#) that allow [open space](#) requirements to be satisfied through LID stormwater management techniques. For projects within Municipalities, please check with their staff to see if they have incentives for using LID BMPs.

**Figure 2.4. Environmental Resources Assessment Checklist**

The use of the Environmental Resources Assessment Checklist is required ONLY for projects within unincorporated Alachua County

	<p><b>Alachua County, Board of County Commissioners</b>                  Department of Growth Management                  10 SW 2nd Ave., Gainesville, FL 32601                  Tel. 352.374.5249, Fax. 352.338.3224  <a href="http://growth-management.alachua.fl.us">http://growth-management.alachua.fl.us</a></p>	<p>Submit to:                  Development Services Division</p>		
<p><b>ENVIRONMENTAL RESOURCES ASSESSMENT CHECKLIST</b></p> <p>Pursuant to Alachua County Comprehensive Plan 2002, as amended, Conservation Open Space Element Policy 3.4.1, applications for land use change, zoning change, and development approval shall be required to submit an inventory of natural resource information. The inventory shall include site specific identification, analysis and mapping of each resource present on or adjacent to the site. The identification and analysis shall indicate information sources consulted.</p>				
<p><b>Natural Resources Checklist:</b>                  Check "Yes" for each resource or resource characteristic identified and discuss and provide supporting material.                  Check "N/A" for each resource or resource characteristic not present or otherwise relevant to the application.</p>				
Yes	<input type="checkbox"/>	N/A	<input type="checkbox"/>	Surface Waters (ponds, lakes, streams, springs, etc.)
Yes	<input type="checkbox"/>	N/A	<input type="checkbox"/>	Wetlands
Yes	<input type="checkbox"/>	N/A	<input type="checkbox"/>	Surface Water or Wetland Buffers
Yes	<input type="checkbox"/>	N/A	<input type="checkbox"/>	Floodplains (100-year)
Yes	<input type="checkbox"/>	N/A	<input type="checkbox"/>	Special Area Study Resource Protection Areas (Cross Creek, Idylwild/Serenola, etc)
Yes	<input type="checkbox"/>	N/A	<input type="checkbox"/>	Strategic Ecosystems (within or adjacent to mapped areas)
Yes	<input type="checkbox"/>	N/A	<input type="checkbox"/>	Significant Habitat (biologically diverse natural areas)
Yes	<input type="checkbox"/>	N/A	<input type="checkbox"/>	Listed Species/Listed Species Habitats (FNAI S1, S2, & S3; State or Federally E, T, SSC)
Yes	<input type="checkbox"/>	N/A	<input type="checkbox"/>	Recreation/Conservation/Preservation Lands
Yes	<input type="checkbox"/>	N/A	<input type="checkbox"/>	Significant Geological Features (caves, springs, sinkholes, etc.)
Yes	<input type="checkbox"/>	N/A	<input type="checkbox"/>	High Aquifer Recharge Areas
Yes	<input type="checkbox"/>	N/A	<input type="checkbox"/>	Wellfield Protection Areas
Yes	<input type="checkbox"/>	N/A	<input type="checkbox"/>	Wells
Yes	<input type="checkbox"/>	N/A	<input type="checkbox"/>	Soils
Yes	<input type="checkbox"/>	N/A	<input type="checkbox"/>	Mineral Resource Areas
Yes	<input type="checkbox"/>	N/A	<input type="checkbox"/>	Topography/Steep Slopes
Yes	<input type="checkbox"/>	N/A	<input type="checkbox"/>	Historical and Paleontological Resources
Yes	<input type="checkbox"/>	N/A	<input type="checkbox"/>	Hazardous Materials Storage Facilities
Yes	<input type="checkbox"/>	N/A	<input type="checkbox"/>	Contamination (soil, surface water, ground water)
<p><b>SIGNED:</b> _____ <b>PROJECT #</b> _____ <b>DATE:</b> _____</p>				
<p>For assistance please visit the Alachua County Environmental Protection Department (ACEPD) website at <a href="http://www.alachuacounty.us/government/depts/epd/natural/devchecklist.aspx">http://www.alachuacounty.us/government/depts/epd/natural/devchecklist.aspx</a> or contact ACEPD at (352) 264-6800. (version 5/20/05)</p>				

Figure 2.5. Stormwater LID BMPS at the Lot Scale

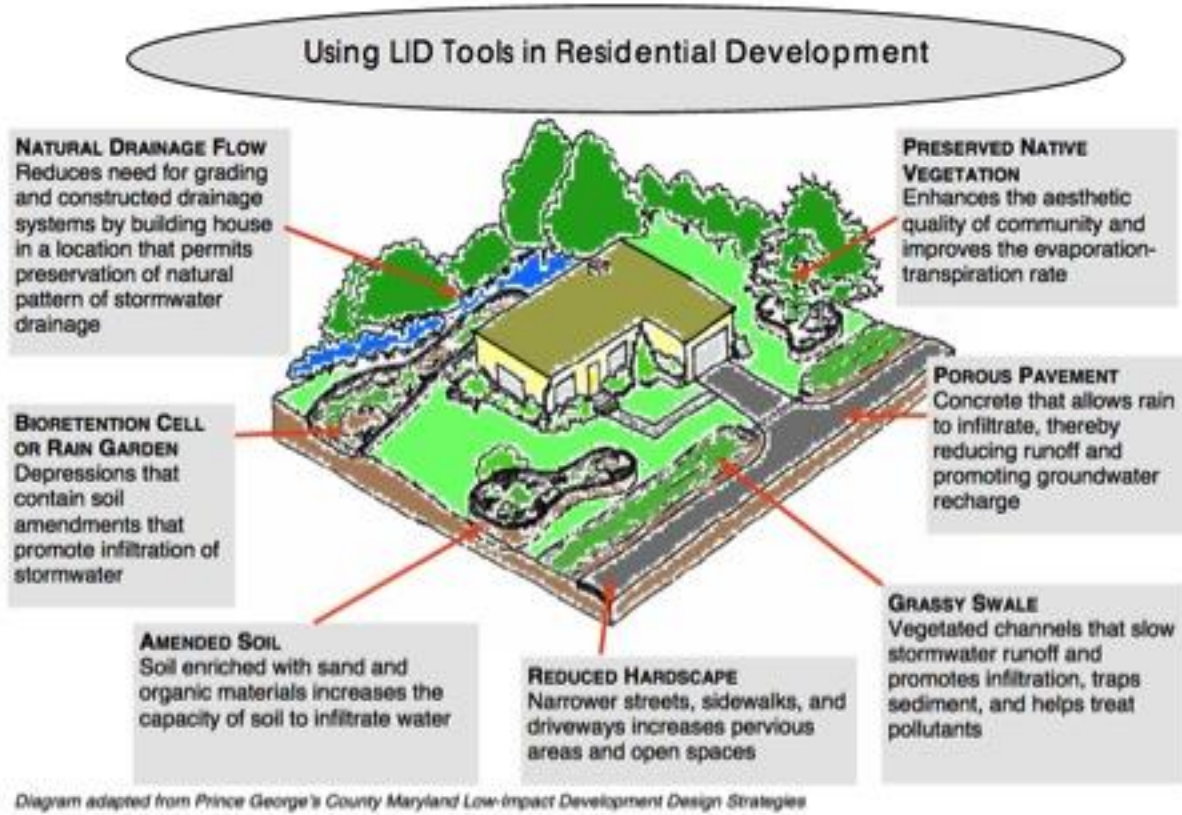

Figure 2.6. Stormwater LIDs at the Lot Scale (Medera Model Home)



Source: Dr. Glenn Acomb, PREC Photo Library

Stormwater is a valuable freshwater resource that can be captured and used for a variety of non-potable purposes. Cisterns or rain barrels can be used for collecting, storing, and using rainwater for irrigating lawns and landscape beds, irrigating green roofs, washing vehicles, and toilet flushing as approved by state and Alachua County health codes. [Detention systems](#) can incorporate “[stormwater harvesting](#)” to reduce stormwater volume and pollutant loading discharges and save valuable freshwater for landscape irrigation or non-potable purposes.

Table 2.1 summarizes the functional aspects of LID BMPs and the timing during the construction process for their implementation. Remember that LID BMPs must be considered very early in the design process, especially their feasibility and potential location on the site. This information can be used together with the Stormwater BMP Strategies Checklist ([Table 6.1](#)) to facilitate the design of BMP Treatment Trains that incorporate LID strategies and BMPs. The BMP checklist is separated into three “phases” roughly parallel to key phases of land development and stormwater planning: conceptual site planning BMPs, source control BMPs, and stormwater BMPs.

**Table 2.1. Functional Aspects and Timing of LID BMPs**

LID technique	Emphasized functional aspects					Occurrence during construction
	Infiltration	Runoff minimization	Runoff reuse	Water quality improvement	Reduced maintenance & water usage	
Amending disturbed or compacted soil						late
Permeable pavement or paving often with under-pavement storage						middle
Grassy or vegetated swales on uncompacted soil (often with curb elimination or curb cuts)						early to middle
Dry wells or exfiltration tanks						middle
Bioretention (rain garden)						middle to late
Tree boxes and tree filters						middle to late
Vegetated Natural Buffers (VNB)						early
Tree canopy retention and drip line root protection						very early
Neighborhood design						very early
Reducing Directly Connected Impervious Areas (DCIA)						early
Green roofs (vegetated roofs)						middle
Minimization of site disturbance and/or construction footprint						early
Cisterns and rain barrels						middle to late
Stormwater reuse ponds						middle to late
Florida Friendly native landscaping						late
Drip irrigation						late

## 2.7. References Cited

James Han, Stormwater Filtration of Toxic Heavy Metal Ions Using Lignocellulosic Materials Selection Process, Fiberization, chemical Modification, and Mat Formation, US Department of Agriculture, Forest Service, <http://www.treesearch.fs.fed.us/pubs/5758>

Economic Factors that Influence Developers' Decisions, ECONorthwest (June 2011)  
<http://doee.dc.gov/sites/default/files/dc/sites/d DOE/publication/attachments/ECONW%20Final%20Report%202011-0628.pdf>

U.S. Department of Housing and Urban Development – Partnership for Advancing Technology in Housing (PATH). Low-Impact Development in the Madera Community, Gainesville, Florida. Case Study, August 2005.

Low Impact Development at the Local Level: Developers Experiences and City and County Support. ECONorthwest. February 2009

Glenn Acomb. LID vs. Conventional Site Design: The Madera Case Study. Land Development. Fall 2009, 22-27.



# ALACHUA COUNTY STORMWATER MANAGEMENT MANUAL



## PART B





Page intended to be blank

# CHAPTER 3. GENERAL STORMWATER REQUIREMENTS AND CRITERIA

## 3.1. Introduction

This chapter summarizes some of the stormwater permitting requirements of FDEP and the WMDs as implemented through the [Environmental Resource Permitting](#) (ERP) program. It also includes general requirements for stormwater treatment systems serving projects in unincorporated Alachua County and the flood control requirements for Alachua County and the municipalities within the county.

## 3.2. Compatibility with State Environmental Resource Permitting (ERP) Rules

Development projects in Alachua County usually will also require permits under the Statewide Environmental Resource Permitting Rules ([Chapter 62-330](#), F.A.C.) implemented by FDEP and the WMDs. Both State and County requirements for stormwater management share the common goal of ensuring that stormwater discharges do not cause flooding or cause or contribute to violations of State water quality standards. This Manual is written with the intent of being compatible with State rules. Applicants should be cautioned, however, that the thresholds, criteria and design standards in this Manual are not necessarily identical to those in State rules. This Manual includes the FDEP's erosion and sediment control requirements and the Sensitive Karst Area requirements of the SJRWMD.

## 3.3. Criteria Flexibility and Alternative Designs

Innovative approaches to stormwater management are encouraged to ensure concurrent control of erosion, sedimentation, flooding, and water quality. An applicant may propose alternative designs to the stormwater quality and quantity design criteria provided in this Manual. Alternative designs will be considered by the applicable County or City staff in determining whether, based on plans, storm and load monitoring data, test results, or other information, the alternative design is suitable for the specific site conditions, and provides equivalent water quality and quantity treatment to that required by the performance standards in this Manual. In otherwise determining whether reasonable assurance has been provided for compliance with this paragraph, the applicable County or City staff shall consider:

- Whether the proposed system will provide the level of attenuation, storage and treatment required by the performance standards in this Manual; and
- Whether reasonable provisions have been made to ensure that the system will be effectively operated and maintained.

## 3.4. Presumptive Criteria

Requirements established in this Manual for [stormwater management systems](#) are based on performance standards ([Section 4.3](#)) and BMP design criteria ([Chapter 5](#)) that are **presumed** to enable those systems to meet the stormwater goals and objectives provided herein. For the purposes of this manual, BMP effectiveness is based on removal of nutrients (total nitrogen and total phosphorus). **It is presumed that systems designed to achieve adequate treatment efficiencies for nutrients will adequately treat other pollutants that could otherwise cause**

**or contribute to water quality violations.** A presumptive approach allows applicants to provide reasonable assurance that stormwater management systems will comply with County/City codes without requiring monitoring or substantial amounts of site-specific information. The presumption is rebuttable however, by either the applicant or the County/City, if site-specific information exists that indicates County/City goals and objectives will not be met unless additional or alternative measures are taken. The LID BMP design criteria in this Manual are presumptive criteria. They are based on the latest Florida BMP monitoring information. However, since they are not included in current ERP Applicant Handbooks, some of the LID BMPs may be permitted by the WMDs as alternative designs.

### 3.5. Applicability of Stormwater Management Requirements

The requirements set forth in this Manual shall apply to new [development](#), also called "[greenfield development](#)".

For projects in Unincorporated Alachua County, the [Alachua County Comprehensive Plan](#) and the [Unified Land Development Code](#) provide general and specific requirements associated with the management of stormwater and the protection of the county's natural resources. The Comprehensive Plan includes goals, objectives and policies associated with minimizing impacts from stormwater. The following elements address the County's adopted goals with respect to stormwater and protecting water resources:

- Conservation and Open Space Element
- Stormwater Management Element

Finally, the Alachua County Unified Land Development Code includes numerous Chapters that protect surface and ground waters and specify requirements for the design, construction, operation, and maintenance of stormwater management systems. These include:

- Chapter 406, Natural and Historic Resources Protection
  - Article 6, Surface Waters and Wetlands
  - Article 7, Flood Hazard Areas
  - Article 8, Springs and High Aquifer Recharge Areas
  - Article 10, Wellfield Protection
- Chapter 407, General Development Standards
  - Article 4, Landscaping
  - Article 5, Open Space
  - Article 7, Traditional Neighborhood Development and Transit Oriented Developments
  - Article 8, Subdivision Regulations
  - Article 9, Stormwater Management
  - Article 11, Potable Water, Wastewater, and Reclaimed Water Service

For projects located within Municipalities, please obtain the appropriate Comprehensive Plan and Land Development Code to determine how they may apply to your project.

For projects within Unincorporated Alachua County and within Municipalities, the requirements in the following Chapters in Part II of the Alachua County Code of Ordinances apply:

- Chapter 73, Environment
- Chapter 77, Water Quality Standards and Management Practices
- Chapter 78, Fertilizers
- Chapter 79, Irrigation Conservation Standards and Management Practices
- Chapter 353, Hazardous Materials Management Code

### **3.6. County/City Approval and Authorizations**

#### **3.6.1. Development Approval Required**

No person shall initiate any construction activity, or construct a stormwater management system, without complying with the provisions of this Manual. The following activities shall require review and approval by the County/City prior to the initiation of any project:

- Clearing and/or draining of land for development purposes.
- Clearing and/or draining of nonagricultural land.
- Converting agricultural lands to nonagricultural uses.
- Subdivision of land where road improvements are required.
- Alteration of land and/or the construction of a structure or other impervious surfaces or a change in the size of one or more structures.
- Creation of 1,000 square feet or more of impervious surface

#### **3.6.2. Exemptions**

The following activities shall be exempt from the requirements of this Manual:

1. Bona fide agriculture. Ongoing agriculture and silviculture farming operations that are not part of a development application and that meet the provisions and criteria pursuant to F.S. Chapter 163.3162, the Agricultural Lands and Practices Act, or F.S.823.14(6), the Right to Farm Act, shall be exempt.
2. The construction, alteration, or maintenance of a single-family residence and accessory structures.
3. A group of single-family residences and accessory structures in unincorporated Alachua County constructed as part of a Family Homestead Subdivision in accordance with the requirements of §407.75 where clearing and drainage does not adversely impact adjacent properties by diverting runoff.
4. Roadway modifications within existing County or municipal road rights-of-way, provided the cross-sectional volume capacity of the existing roadside swale is not reduced and provided that there are no downstream impacts.
5. Redevelopment Projects.
6. Off-site compensating treatment facilities permitted and constructed prior to the effective date of this Article.
7. Projects discharging to exempt facilities that have also obtained a modification to the Water Management District permit for the compensating treatment facility.
8. Stormwater facilities that have already applied for development approval by the Stormwater Treatment Code's adoption date or have already received State or local approval by the Code's effective date.

### 3.6.3. Waivers

(a) A waiver from specific requirements of this section may be granted by the County where a proposed building addition will not result in significant adverse impacts to stormwater quality; the environment; or public health, safety, or welfare. It is the property owners' burden to demonstrate that a waiver is warranted.

(b) Development activities located on parcels with total land area less than 1 acre in size may be eligible for a partial waiver from the stormwater treatment Performance Standards in Section 77.21 based on a demonstration by the applicant that meeting these standards is not technically feasible. A technical feasibility analysis must be submitted to demonstrate that higher levels of treatment are not achievable.

### 3.6.4. Documents Incorporated By Reference

All stormwater management systems must be designed and implemented to meet the design and performance criteria set forth in this Manual. In addition, the following documents are incorporated herein by reference, for supplemental standards and methodologies for use in designing, implementing, and maintaining stormwater management systems and erosion and sediment control systems:

Chapter 40B-4, Florida Administrative Code (F.A.C.), Suwannee River Water Management District, Works of the District Permits;

Chapter 40B-400, F.A.C. Suwannee River Water Management District, Environmental Resource Permits. Include Applicant's Handbook Volumes 1 and 2.

Chapter 40C-4, F.A.C., St. Johns River WMD, Environmental Resource Permits: Surface Water Management Systems. Includes Applicant's Handbook Volumes 1 and 2.

Chapter 40C-42, F.A.C., St. Johns River WMD, Environmental Resource Permits: Regulation of Stormwater Management Systems

Chapter 62-4, F.A.C., Department of Environmental Protection (FDEP), Permits;

Chapter 62-302, F.A.C., FDEP, Water Body Classifications and Water Quality Standards

Chapter 62-302.700, F.A.C., FDEP, Special Protection (FDEP), Outstanding Florida Waters, Outstanding Natural Resource Waters;

Chapter 62-330, F.A.C., FDEP, Environmental Resource Permitting. Includes Applicant's Handbook Volume 1 and the Volume 2 Applicant's Handbooks of each of the WMDs.

Chapter 62-528, F.A.C., FDEP, Underground Injection Control

Chapter 62-621, F.A.C., FDEP, Generic Permits;

Chapter 62-624, F.A.C., FDEP, Municipal Separate Storm Sewer Systems;

Chapter 77, Code of Ordinances, Alachua, Florida, Water Quality Code

Chapter 353, Code of Ordinances, Alachua, Florida, Hazardous Waste;

The Florida Stormwater, Erosion and Sedimentation Control Inspector's Manual, FDEP;

State of Florida Erosion and Sediment Control Designer and Reviewer Manual, (July 2013),

Florida Department of Transportation (FDOT) and Florida Department of Environmental Protection (FDEP).

Drainage Manual, State of Florida Department of Transportation; and

A Policy on Geometric Design of Highways and Streets, American Association of State Highway and Transportation Officials (AASHTO).

### 3.7. Flood Control Requirements

The focus of this Manual is on the stormwater treatment requirements of stormwater management systems built in Alachua County. Alachua County is within both the Suwannee River Water Management District (SRWMD) and the St. Johns River Water Management District (SJRWMD). Please contact the appropriate Water Management District and County or City staff to obtain the appropriate flood control requirements.

### 3.8. Requirements in Chapter 407, Article 9 – Stormwater Management

For stormwater systems serving a project within Unincorporated Alachua County, the requirements in Chapter 407, General Development Standards, of the Unified Land Development Code shall apply. If a project is within a Municipality please check their Land Development Code for applicable requirements.

Within Chapter 407, please note the following Sections of [Article 9](#) for the design of stormwater management systems:

Section 407.91 (e), General Engineering and Environmental Standards  
Section 407.92, Relationship to Project Design and General Design Criteria  
Section 407.92(c), Fencing of Stormwater Management Systems

In addition, the following two sections of the Alachua County Unified Land Development Code shall apply to stormwater systems serving projects within Unincorporated Alachua County:

Landscaping Design of Stormwater Management Facilities in [Section 407.43.2](#) of the Alachua County ULDC.

Requirements for Stormwater Management Areas Used as Open Space in [Section 407.56](#) of the Alachua County ULDC.

### 3.9. Erosion and Sediment Control

#### 3.9.1. Overview

Uncontrolled erosion and sediment from land development activities can result in costly damage to aquatic systems and to both private and public lands. Excessive sediment blocks stormwater conveyance systems, plugs culverts, fills navigable channels, impairs fish spawning, clogs the gills of fish and invertebrates, and suppresses aquatic life.

A plan for minimizing erosion and controlling sediment through the implementation of appropriate BMPs must be included with the application for a stormwater permit. The Erosion and Sedimentation Control Plan shall be prepared by a [Registered Professional](#).

An effective sediment and erosion control plan is essential for controlling stormwater pollution during construction. An erosion and sediment control plan is a site-specific plan that specifies the location, installation, and maintenance of best management practices to prevent and control erosion and sediment loss at a construction site. The plan is submitted as part of the permit application and must be clearly shown on the construction plans for the development. Erosion and sediment control plans range from very simple for small, single-phase developments too complex for large, multiple phased projects. If, because of unforeseen circumstances such as extreme rainfall events or construction delays, the proposed erosion and sedimentation controls no longer provide reasonable assurance that water quality standards will not be violated,



additional erosion and sediment control measures shall be required that must be designed and implemented to prevent violations of water quality standards.

### 3.9.2. Erosion and Sediment Control Requirements

Erosion and sediment control BMPs shall be used as necessary during construction to retain sediment on-site and assure that any discharges from the site do not cause or contribute to a violation of Florida's turbidity standard, (29 NTU above background). These BMPs must be designed to accommodate specific site conditions and shall be shown or clearly referenced on the construction plans for the development. At a minimum, the erosion and sediment control requirements described in this section shall be followed during construction of the project. Additional measures are required if necessary to protect wetlands or prevent off-site flooding. All appropriate contractors must be furnished with the information pertaining to the implementation, operation, and maintenance of the erosion and sediment control plan. In addition, sediment accumulation in the stormwater system from construction activities must be removed prior to final certification of the system to ensure that the designed and permitted storage volume is available.

### 3.9.3. Erosion and Sediment Control Principles

Factors that influence erosion potential include soil characteristics, vegetative cover, topography, climatic conditions, timing of construction, and the areal extent of land clearing activities. The following principles must be considered in planning and undertaking construction and alteration of surface water management systems:

- Plan the development to fit the existing topography, soils, drainage patterns, and natural vegetation of the site;
- Minimize both the extent of area exposed at one time and the duration of exposure;
- Schedule activities during the dry season or during dry periods whenever possible to reduce the erosion potential;
- Apply erosion control practices to minimize erosion from disturbed areas;
- Stockpiling and storage of materials shall not impede flow or cause materials to be eroded by stormwater or rainfall.
- Apply perimeter controls to protect disturbed areas from off-site runoff and to trap eroded material on-site to prevent sedimentation in downstream areas;
- Keep runoff velocities low and retain runoff on-site;
- Stabilize disturbed areas immediately after final grade has been attained or during Interim periods of inactivity resulting from construction delays; and
- Implement a thorough maintenance and follow-up program.

These principles are usually integrated into a system of vegetative and structural measures, along with other management techniques, that are included in an erosion and sediment control plan to minimize erosion and control movement of sediment. In most cases, a combination of limited clearing and grading, limited time of exposure, and a judicious selection of erosion control practices and sediment trapping systems will prove to be the most practical method of controlling erosion and the associated production and transport of sediment. Permit applicants, system designers, and contractors can refer to the [State of Florida Erosion and Sediment Control Designer and Reviewer Manual \(July 2013\)](#) and the [Florida Stormwater, Erosion, and Sediment Control Inspector's Manual \(FDEP July 2008\)](#), for further information on erosion and sediment control. These manuals provide guidance for the planning, design, construction, and maintenance of erosion and sediment control practices.

### 3.9.4. Development of an Erosion and Sediment Control Plan

An Erosion and Sediment Control Plan must be submitted to the applicable County or City to provide reasonable assurance that [water quality standards](#) will not be violated during the construction phase of a project. The plan shall identify permanent stormwater conveyance structures, final stabilized conditions of the site, provisions for removing temporary control measures, stabilization of the site when temporary measures are removed, and maintenance requirements for any permanent measures. All sedimentation control structures to be used during construction shall be installed prior to any construction activity and shall be maintained in an effective condition until the completion of the permanent stormwater management system or other erosion control measures to assure adequate erosion and sediment control. The plan must identify the location, relative timing, and specifications for all erosion and sediment control and stabilization measures that will be implemented as part of the project's construction. The plan must provide for compliance with the terms and schedule of implementing the proposed project, beginning with the initiation of construction activities. The plan may be submitted as a separate document, or may be contained as part of the plans and specifications of the construction documents.

All stormwater management facilities shall be stabilized with either grass or sand-based sod. When used, sod shall be certified apparently weed-free sod. The following minimum requirements shall be met:

All dry basin bottoms must be seeded. The seeding mix must provide both long-term vegetation and rapid growth seasonal vegetation. A topsoil mixture may be required in excessively drained sandy soils. Side slopes steeper than 3H:1V must have the sod stapled or pegged. Basin side slopes flatter than 3H:1V may be seeded and mulched or sodded.

Erosion protection at the outlet of all drainage structures shall be provided. For outlet velocities less than three feet per second, pegged or stapled sod must be provided. For velocities greater than three feet per second, an energy dissipation device shall be installed, such as riprap, baffles, or stilling basins.

Sod shall be placed around the full perimeter of all head walls, end walls, and mitered end installations in accordance with the [Florida Department of Transportation's Design Standards for Design, Construction, Maintenance and Utility Operations on the State Highway System](#).

During construction, provisions shall be made to minimize disturbance to and compaction of soils in the basin bottom.

Dewatering and pumping activities shall be permitted for construction purposes provided the dewatering activities will not cause flooding or adverse impacts to downstream conditions.

Either a Dewatering Permit from FDEP or coverage under [the FDEP NPDES Construction Generic Permit](#) is required. Permission from adjacent property owners must be obtained for discharge to privately owned properties. A permit must be obtained from the Alachua County Public Works Department for any off-site discharge to the County right-of-way.

### 3.9.5. Projects larger than 1 Acre Must Obtain NPDES CGP Coverage

Since Alachua County, the City of Gainesville, and FDOT have been issued a NPDES Municipal Separate Storm Sewer System (MS4) permit, their staff must assure that all construction sites comply with the State of Florida's NPDES Construction Generic Permit (CGP) pursuant to subsection 62-621.300(4), F.A.C. Construction activities resulting in greater than 1 acre of soil disturbance must also apply for and receive coverage from FDEP under Florida's NPDES Construction Generic Permit before disturbing the soil.

The NPDES Construction Generic Permit (CGP) is adopted by reference in Chapter 62-621.300(4), F.A.C., and is available online at: <http://www.dep.state.fl.us/water/stormwater/npdes/construction3.htm>. The CGP consists of the following nine parts:

- Part 1 – Permit Coverage
- Part 2 – Your Application (Notice of Intent)
- Part 3 – Discharges
- Part 4 – Stormwater Pollution Prevention Plan (SWPPP)
- Part 5 – Best Management Practices (BMPs)
- Part 6 – Inspections and Records
- Part 7 - Completion (Notice of Termination)
- Part 8 – Definitions and Acronyms
- Part 9 – Standard Permit Conditions

**3.10. Inspection of Stormwater Treatment Systems**

For projects within Unincorporated Alachua County, the County will provide inspection services during the construction activities of all approved stormwater management systems. Any duly authorized representative of the County at any reasonable time may enter and inspect property on which a stormwater management system is located to determine compliance of proposed or constructed stormwater management systems with this Manual or any applicable county ordinances, or consistency with any development application or development approval. The duly authorized representative of the County may collect water quality samples and obtain other information necessary to determine compliance of the stormwater management system. No person shall refuse reasonable entry or access to any authorized representative of the County who requests entry for purposes of inspection and who presents appropriate credentials.

For projects within a Municipality, please check with their staff regarding inspections during construction activities of the approved stormwater management system.

Stormwater treatment systems must be inspected and maintained on a regular basis as set forth in this Manual to assure that systems continue to function as permitted. In addition to the regular inspections required by each BMP, a Registered Professional is required to inspect the entire permitted stormwater treatment system according to the schedule set forth in the applicable ERP issued by either the SJRWMD or the SRWMD. If the applicable WMD ERP did not include an inspection schedule then the follow the requirements in Table 3.1. The Registered Professional shall document the inspection using ERP [Form 62-330.311\(1\)](#), [“Operation and Maintenance Inspection Certification.”](#) The form shall be submitted by email to Alachua County within 30 days of inspection, a system failure, or deviation from the permitted design.

**Table 3.1. Stormwater Treatment System Recertification Frequency**

<i>Type of Stormwater Treatment System</i>	<i>During the First Two Years of Operation</i>	<i>After First Two Years of Successful Operation</i>
Retention basins	Annually	Once every 5 years

<i>Type of Stormwater Treatment System</i>	<i>During the First Two Years of Operation</i>	<i>After First Two Years of Successful Operation</i>
Exfiltration trenches	Annually	Once every 24 months
Underground retention	Annually	Once every 24 months
Underground retention vault/chambers	Annually	Once every 24 months
Treatment Swales	Annually	Once every 5 years
Vegetated Natural Buffers	Annually	Once every 24 months
Pervious pavements	Annually	Once every 24 months
Greenroof/cisterns	Annually	Once every 24 months
Wet detention basins	Annually	Once every 5 years
Managed aquatic plant systems	Annually	Once every 24 months
Stormwater harvesting	Annually	Once every 24 months
Depressed basins	Annually	Once every 5 years
Rain gardens	Annually	Once every 24 months
Alum injection	Annually	Once every 24 months

**3.11. Additional Permitting Requirements to Protect Potable Water Supplies**

Pursuant to Chapter [62-555.312\(3\)](#), F.A.C., stormwater retention and detention systems are classified as moderate sanitary hazards with respect to public and private drinking water wells. Accordingly, stormwater treatment facilities shall not be constructed within 75 feet of a public or private drinking water supply well.

**3.12. Hazardous or Toxic Substances**

Stormwater systems serving a land use or activity that produces or stores hazardous or toxic substances shall be designed to prevent exposure of such materials to rainfall and runoff to ensure that stormwater does not become contaminated by such materials. Such land uses may not be appropriate for certain BMPs such as retention basins to minimize introduction of such materials into the ground water.

**3.13. Co-mingling Off-site and On-site Stormwater Runoff**

The specific load reductions required to achieve the performance standards in [Section 4.3](#) apply only to the pollutant load generated from on-site runoff. If stormwater runoff from off-site areas co-mingles with on-site runoff, the stormwater treatment system must be designed to achieve the performance standards in Section 4.3 only for the pollutant load generated by on-site runoff. However, the off-site runoff cannot reduce the pollutant load reduction effectiveness of the BMP(s) being used to treat the stormwater generated on-site.

**3.14. Professional Certification Requirements**

All copies of plans and drawings, together with supporting calculations and documentation submitted to the County must be signed, sealed, and dated by a [registered professional](#), as

required by Chapters 471, 472, 481 or 492, Florida Statutes, as applicable, when the design of the system requires the services of a registered professional.

# CHAPTER 4. STORMWATER QUALITY PERFORMANCE STANDARDS

## 4.1. Introduction

All new [development](#) projects must provide adequate stormwater treatment to not degrade the surface or ground water quality. This includes infill residential development within residential areas or subdivisions existing prior to the adoption of this Stormwater Treatment Manual. Regardless of the type of project, the [stormwater management system](#) must provide a level of treatment that meets or exceeds the requirements set forth in this Manual.

## 4.2. Stormwater Treatment Process Fundamentals

Stormwater pollutant loading is a product of the stormwater volume discharged off-site times the [Event Mean Concentration \(EMC\)](#) of the pollutant(s) of interest. Therefore, to reduce stormwater pollutant loading, one can reduce stormwater volume or stormwater concentration or both. However, as seen in [Table 4.4](#), the stormwater pollutant concentrations are relatively low, especially when compared to the concentrations of pollutants in wastewater. Typically, stormwater pollutant concentrations are like wastewater that has been treated to Advanced Wastewater Treatment standards. **Therefore, in general, the greatest stormwater pollutant load reduction potential is associated with reducing the volume of stormwater discharged off-site.**

However, many BMPs, including source controls, incorporate mechanisms that also reduce stormwater pollutant concentrations. To design BMPs to effectively treat stormwater, it is helpful to understand the basic processes involved and why they remove pollutants. Figure 4.1 illustrates the effect of pollutant particle size on the relative volume of water that can be treated. It also lists groups of BMPs and a range over which each one functions. Following it, Table 4.1 breaks down the basic treatment processes, the BMPs that employ them and what they remove.

Choose treatment BMPs based on the hydraulic loading rate, the expected or measured stormwater pollutants, the type of soil present, the level of treatment required, and the cost.

One problem preventing wider use of LID BMPs for stormwater treatment has been missing or inconsistent data on the pollutant load reduction effectiveness of stormwater LID BMPs. However, since 1999, FDEP and FDOT have funded numerous projects to monitor the effectiveness of conventional and LID BMPs. Links to web sites with many of the LID BMP completed research reports are on the [Acknowledgements](#) page of this Manual.

Additionally, Harper and Baker (2007) summarize information about BMP effectiveness based on monitoring done within Florida.



**Figure 4.1. Stormwater Treatment Tradeoff – Particle Size vs. Hydraulic Loading**

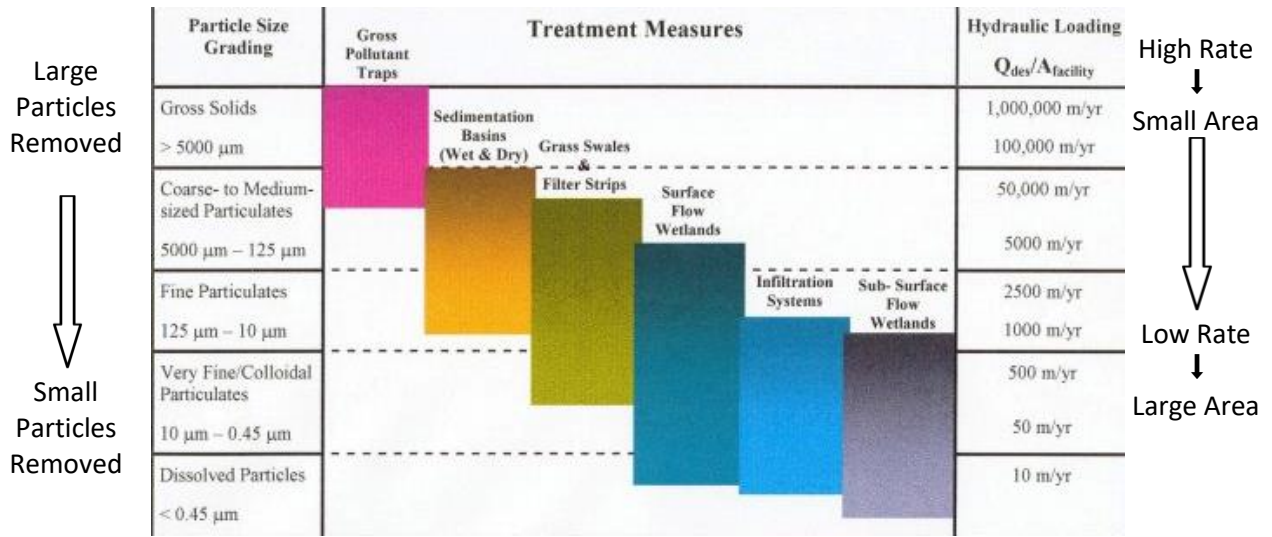

**Table 4.1. Basic Mechanisms of Stormwater Treatment**

Treatment Process	BMP Options	What is Removed?	How Does it Happen?
Flotation	Skimmers oil/water separators density separators	Oil and other hydrocarbons Trash	Substances lighter than water are removed with units specifically designed for this purpose.
Settling/ Sedimentation	Bioretention wetlands wet or dry ponds tree boxes cisterns	Suspended solids, Metals, Particulate phosphorus, Organics	Suspended particles settle by gravity, along with pollutants adhered to them. Forebays must capture and facilitate periodic removal of sediment. Avoid re-suspension of sediment.
Filtration	Sand/gravel filters, natural/amended soil, green roofs, infiltration tanks, horizontal wells.	Suspended solids, Metals, Phosphorus, Organics	Stormwater passes through a porous material, mechanically removing anything larger than the pore openings.
Sorption (adsorption/ absorption/ ion exchange)	Any BMP using infiltration thru soils or other media, especially organic material or clay.	Dissolved nutrients Metals Bacteria	Contaminants adhere to irregularities in the surface of vegetation, to clay particles in soil or are attached to other molecules by chemical bonds.
Biological Removal	Bioretention, enhanced ponds, floating islands	Nitrogen, phosphorus, Organic molecules	Microorganisms and plants take in nutrients needed for their cell growth and break apart large organic molecules.
<b>Treatment Process</b>	<b>BMP Options</b>	<b>What is Removed?</b>	<b>How Does it Happen?</b>

Infiltration	Bioretention areas, retention ponds, wetlands, swales, tree boxes, infiltration tanks.	Suspended solids, Metals, Particulate phosphorus, Organics	As water moves from the surface into soil voids, contaminants are removed by a combination of filtration, sorption to soil and biological removal.
Degradation in open water	Wetlands and ponds with open water	Organic molecules	Some volatile compounds move into the atmosphere, and sunlight photolysis can break apart others.
Hydrodynamic Separation	Various commercial devices	Light hydrocarbons and trash Sediment and attached pollutants	The internal structure of the device may use a skimmer to remove things lighter than water, and it may create a vortex and/or a stilling basin to separate heavier sediment.
Chemical Precipitation	Cisterns or other stormwater storage before reuse.	Fine suspended solids Metals Organics	Chemicals such as alum attract small particles to charged ions, creating larger particles that can be removed by sedimentation. Not common unless stormwater is being treated for reuse.

**4.3. Stormwater Treatment Performance Standards**

Florida’s Environmental Resource Permitting program is based on minimum levels of stormwater treatment (the Performance Standard) and BMP design criteria that are presumed to achieve the desired level of load reduction. The Performance Standard will vary with the health of the receiving water body. Except for exempt projects meeting the criteria in [Subsection 3.6.2](#), a stormwater treatment system shall be designed to achieve the minimum level of treatment specified below as applicable to the development project and its location:

1. Projects that discharge directly or indirectly to surface waters - Reduce the [post-development](#) annual average stormwater total nitrogen load by at least 70% and the annual average stormwater total phosphorus load by at least 80%. This means that 30% of the post-development total nitrogen load and 20% of the total phosphorus load may be discharged. Depending on pre-development conditions, this may still represent an increase in load.
2. Projects that directly discharge to Outstanding Florida Waters – Reduce the post-development annual average total nitrogen and total phosphorus load by at least 95%. This means that 5% of the post-development total nitrogen load and total phosphorus load may be discharged. Depending on pre-development conditions, this may still represent an increase in load.
3. Projects within watersheds of [Verified Impaired Water Bodies](#) or Water Bodies with Adopted Nutrient [Total Maximum Daily Loads \(TMDLs\)](#) – Either meet the performance standard in 1 or 2 above or reduce the post-development average annual nitrogen and phosphorus load to at least 10 percent less than the [pre-development](#) average annual nitrogen and phosphorus load, whichever provides the highest amount of average annual nutrient load reduction ([Net Improvement Performance Standard](#)).

4. Projects using retention BMPs within Sensitive Karst Areas – Meet (1), (2), (3) above, as applicable to the surface water, and treat the first inch of runoff from the contributing drainage area with a combination of one or more Low Impact Design techniques separate from the dry retention basin(s).
5. Projects using Rapid Infiltration Stormwater Retention Basins will incorporate appropriate Best Management Practices to reduce the post-development total nitrogen loading into the groundwater by at least 70%.

#### **4.4. Special Basin Criteria**

##### **4.4.1. Sensitive Karst Areas**

The [Floridan Aquifer](#) is the drinking water source for most of the population in Alachua County. In parts of Alachua County. The limestone that comprise this aquifer are at or very near the land surface and potential sources of pollution. Potential contamination of the Floridan Aquifer from surface pollutant sources in these areas is greater than within the rest of the County due to the hydrogeology and geology of these "Sensitive Karst Areas." "Karst" is a geologic term used to describe areas where sinkhole formation is common and landscapes are formed by the solution of limestone.

The Sensitive Karst Area within Alachua County is defined as the areas designated as "High Vulnerability" or "Vulnerable" zones of the Alachua County Aquifer Vulnerability Map (Figure 4.2), and with soil types classified as "excessively drained", "somewhat excessively drained", or "well drained" as defined by the U.S. Department of Agriculture (USDA) Natural Resources Conservation Service (NRCS) Soil Survey Geographic (SSURGO) Database for Florida (Figure 4.3).

Figure 4.2. Alachua County Aquifer Vulnerability Map

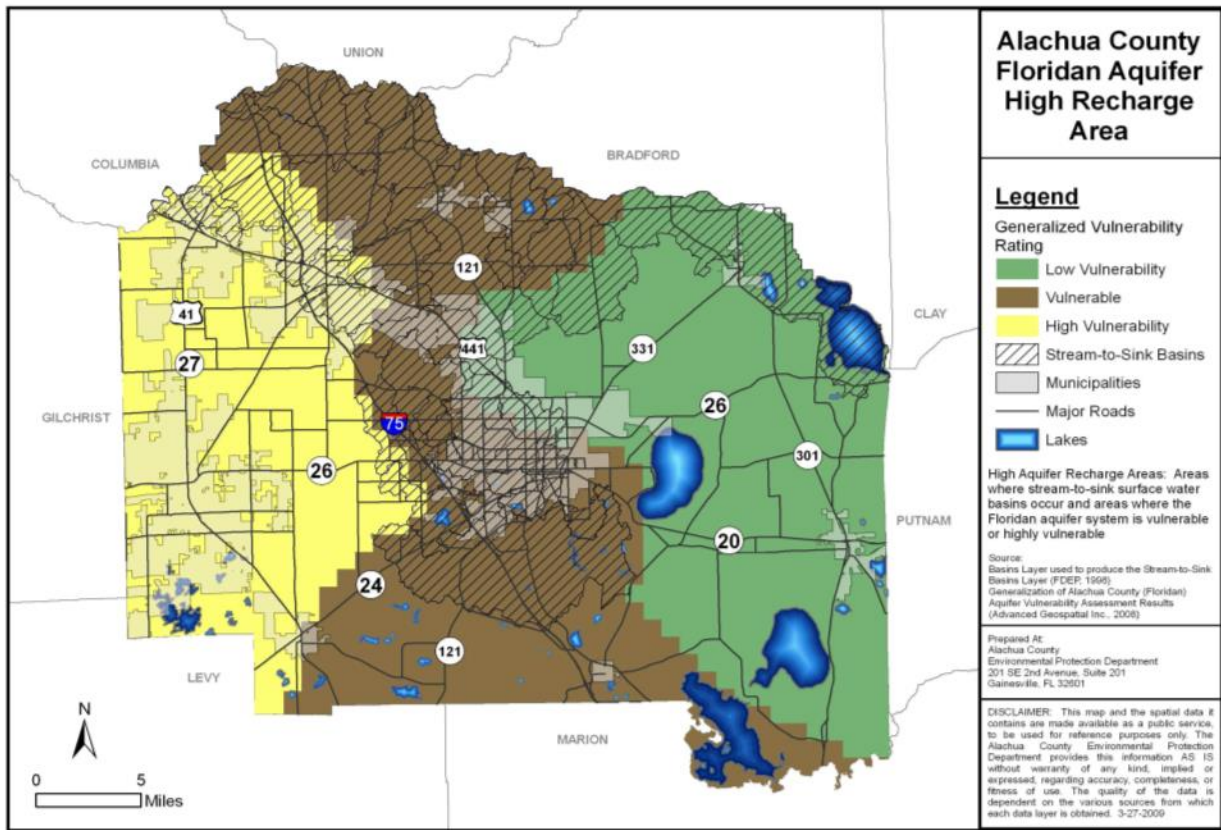

**4.4.1.1. Hydrogeology of the Sensitive Karst Areas Basin**

Throughout the eastern part of Alachua County, the highly porous limestone that contains the Floridan Aquifer is overlain by tens to hundreds of feet of sands, clays, and other material. This material acts as a buffer, isolating the Floridan Aquifer from surface pollutants. Surface water seeps through this material slowly which allows for filtration, adsorption, and biological removal of contaminants.

However, in the Sensitive Karst Areas (SKA) the limestone that contains the Floridan Aquifer exists at, or virtually at, land surface. The absence of cover material allows rapid movement of stormwater into the aquifer with little treatment. The SKA are areas of high recharge for the Floridan Aquifer. Floridan Aquifer ground water levels vary from land surface to approximately 60 feet below land surface in the SKA.

Figure 4.3. Soil Drainage Classes

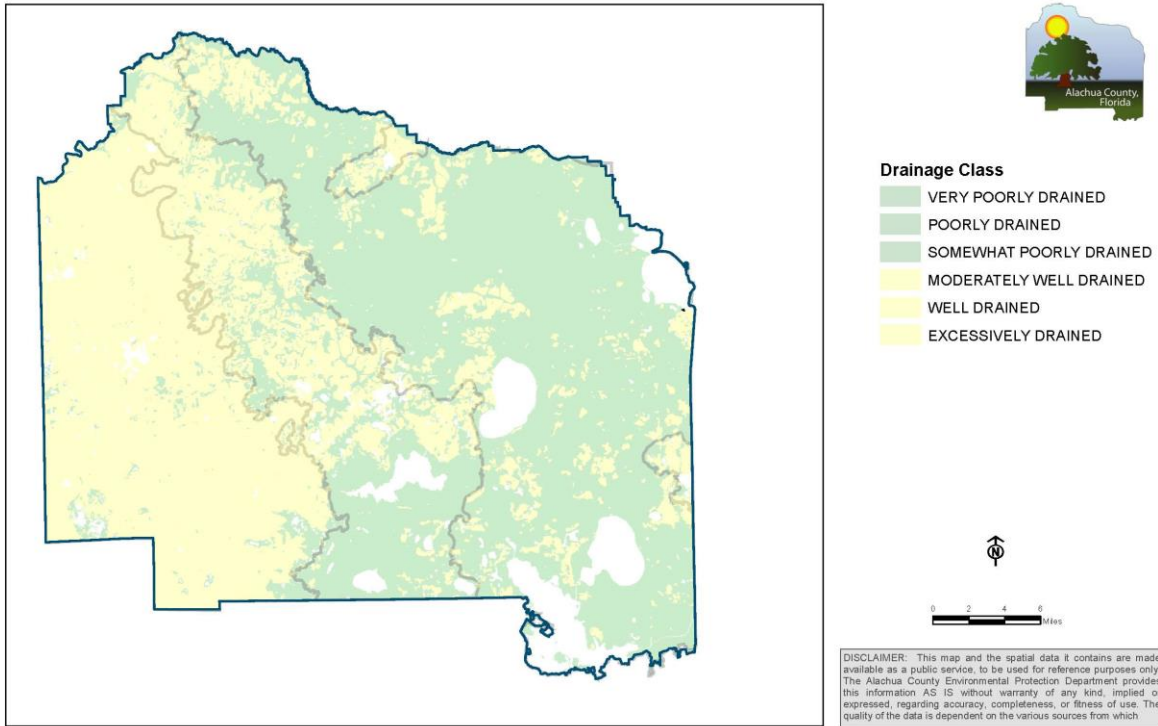

Two factors make the SKA particularly prone to stormwater contamination. The first factor is the very sandy soil with little silt or clay content, low Cation Exchange Capacity, low moisture content, and very aerobic conditions. Typically these include the soils classified as “excessively drained”, somewhat excessively drained, or well drained. These conditions at the area of infiltration promote the transformation of nitrogen into nitrates and allow nitrates to enter the ground water beneath the retention BMP. The use of soil amendments, such as [Biosorption Activated Media \(BAM\)](#), can change these soil characteristics allowing the Nitrogen Cycle to transform the nitrate to nitrogen gas and minimize transport of nitrates into the ground water. The second factor is the formation of solution pipe sinkholes. Within the SKA, solution pipe sinkholes often form in the bottom of stormwater retention basins. The existing capping soil plug may be reduced by excavation of the basin. Stormwater in the basin increases the hydraulic head on the remaining plug. Both factors can wash the plug down the solution pipe. Solution pipes act as natural drainage wells and can drain stormwater basins resulting in contamination of the ground water.

4.4.1.2. SJRWMD Design Criteria for Sensitive Karst Areas

Section 13.6 of the SJRWMD Permit Information Manual (October 1, 2013) includes specific design requirements in Sensitive Karst Areas. The SKAs within Alachua County are shown in Figure 13.0-3 of the Permit Information Manual. Chapter 40-41.063(6), F.A.C., establishes design criteria for BMPs in these KSAs. The design criteria are intended to preclude the



formation of solution pipe sinkholes in retention systems. They include the following minimum design features:

- A minimum depth of three feet of unconsolidated soil material between the surface of the limestone bedrock and the bottom and sides of the retention basins.
- Stormwater basin depth should be as shallow as possible with a horizontal bottom. Use of [Site Planning BMPs](#) and [Source Control BMPs](#) integrated into a [BMP Treatment Train](#) is highly recommended;
- Maximum stormwater basin depth of ten feet; and
- Fully vegetated basin side slopes and bottoms.

Depending on the potential for contamination to the Floridan Aquifer, more stringent criteria may be required by the SJRWMD. Industrial and some commercial sites will normally require more stringent design features. Some of the more stringent site-specific design requirements that may be necessary include:

- More than three feet of unconsolidated soil material between limestone bedrock surface and the bottom and sides of the stormwater basin.
- Basin liners--clay or geotextile.
- Sediment sumps at stormwater inlets.
- Off-line treatment.
- Paint/solvent and water separators.
- Trash traps.
- Hydrodynamic separators.

Utility lines shall not be installed beneath stormwater basins in karst areas. Any line for temporary irrigation of vegetation in and around stormwater management systems shall be installed to minimize excavation in karst areas.

#### **4.4.2. Projects within Watersheds of Impaired Water Bodies or Water Bodies with Adopted Total Maximum Daily Loads (TMDLs)**

Section 373.414(1)(B)3, F.S., establishes the “Net Improvement” performance standard. It states:

3. If the applicant is unable to meet water quality standards because existing ambient water quality does not meet standards, the governing board or the department shall consider mitigation measures proposed by or acceptable to the applicant that cause net improvement of the water quality in the receiving body of water for those parameters which do not meet standards.

The FDEP and the WMDs interpret this to mean that the post-development average annual stormwater pollutant loading must be less than the pre-development loading for the pollutant(s) of concern. However, as set forth in [Section 4.3.3](#) the “net improvement” performance standard requires the [post-development](#) average annual stormwater pollutant loading to be at least 10 percent less than the [pre-development](#) loading.



**When is a project required to meet the “Net Improvement” performance standard? “Net improvement” will be required if a project is located within the boundary of a WBID that is on the Verified List of Impaired Waters or for which a TMDL has been adopted**

[Appendix A](#) lists the [WBIDs](#) within Alachua County and notes whether they are impaired, have an adopted TMDL, or an adopted BMAP. To see if “Net Improvement” applies to a specific project, discuss this with the permitting staff during a pre-application meeting. In some cases, the SJRWMD may use the 12 digit Hydrologic Unit Code boundary to apply “Net Improvement”. To determine if your project is within the HUC 12 sub-watershed or a WBID, use FDEP’s Map Direct System at: <http://ca.dep.state.fl.us/mapdirect/?focus=tmdlvi>

Net Improvement applies to all impaired water bodies where the pollutant causing the impairment is TN, TP or BOD<sub>5</sub>. However, if a water body is impaired for Fecal Coliform, the “Net Improvement” performance standard in Section 4.3.3 does not apply. As discussed in [Section 3.4](#), stormwater treatment systems designed to achieve the required treatment efficiencies for TN and TP will adequately treat other pollutants that could otherwise cause or contribute to water quality violations.

#### 4.5. Rapid Infiltration Stormwater Retention Basins

Rapid Infiltration Stormwater Retention Basins means a constructed vertical drainage connection between the retention basin and a more pervious underlying geological formation, typically the Floridan aquifer. It typically incorporates removal and replacement of a semi-confining or confining soil layer with a more permeable material. These structures are used to allow the flood control volume recovery requirements to be met.

However, these structures must comply with Federal, State, and local requirements. These include the Federal Safe Drinking Water Act and Federal and state regulations of Underground Injection Control Wells. An injection well is used to place fluid underground into porous geologic formations. These underground formations may range from deep sandstone or limestone, to a shallow soil layer. Injected fluids may include water, wastewater, brine (salt water), or water mixed with chemicals.

The definition of a well is codified in the UIC regulations at 40 CFR 144.3.

Well means: A bored, drilled, or driven shaft whose depth is greater than the largest surface dimension; or, a dug hole whose depth is greater than the largest surface dimension; or, an improved sinkhole, or, a subsurface fluid distribution system.

Within Florida, the FDEP has adopted [Chapter 62-528, F.A.C.](#), to regulate the six classes of Underground Injection Control wells. Class V injection wells are wells used for the storage or disposal of fluids into or above a USDW. The fluid injected must meet appropriate criteria as determined by the classification of the receiving aquifer. Common types of Class V wells include air conditioning return flow wells, swimming pool drainage wells, stormwater drainage wells, lake level control wells, domestic waste wells, and aquifer storage and recovery (ASR) wells (see below). There are more than 13,000 Class V wells in Florida. Stormwater drainage wells are classified as Non-Major Class V Wells that are permitted through FDEP’s District Offices.

To minimize introduction of pollutants into the ground water the following requirements apply to drainage bore holes:

1. They will not meet the definition of a well. That is, they are wider than they are deep.
2. They will incorporate appropriate BMPs to reduce the post-development total nitrogen loading into the ground water by at least 70%.

To meet the ground water protection Performance Standard above in the most cost-effective manner, a stormwater treatment train of Low Impact Design BMPs is required. This can include some or several of the following BMPs:

- A. Site Planning BMPs including [SP5](#), [SP6](#), [SP7](#), [SP8](#), [SP9](#), [SP10](#), [SP11](#), and [SP12](#).
- B. Source Control BMPs including [SC1](#), [SC2](#), [SC3](#), [SC4](#), [SC5](#), [SC6](#), [SC7](#), [SC8](#), and [SC9](#).
- C. [Green roofs](#) with cisterns (SW8)
- D. [Pervious pavement \(SW7\)](#)
- E. Replace the three feet of unconsolidated soil material with two feet of [Biosorption Activated Media](#) (BAM)
- F. Lined BMPs with [stormwater harvesting \(SW11\)](#)
- G. [Filter systems](#) using BAM (SW12, SW14)

#### 4.6. Calculating Stormwater Pollutant Loading

A methodology for calculating site-specific annual average stormwater pollutant loadings is provided below. The methodology is based on the one set forth in [Harper and Baker \(2007\)](#).

##### 4.6.1. Calculation of Pre-Development and Post-Development Hydrology

To calculate hydrology and pollutant loading from the proposed project, develop a table similar to Table 4.2 to summarize land use information. Determine the [pre-development](#) and [post-development](#) characteristics of each of the individual [watersheds](#) or drainage basins at the project site. The Directly Connected Impervious Area (DCIA) consists of those [impervious areas](#) that are directly connected to the stormwater conveyance system. Impervious areas also are considered to be DCIA if stormwater from the area occurs as concentrated shallow flow over a short pervious area such as grass or a swale. **Non-directly connected impervious areas include all pervious areas and portions of impervious areas that flow over at least 10 feet of pervious areas with HSG A or B soils and over at least 20 feet of pervious area for other soil types.**

**Table 4.2. Example Land Use Categories Matrix to Calculate Loadings**

Land Use	Total area	Non-DCIA CN	DCIA percentage
Pre-development			
Low Density Residential			
Single Family			
Multi-Family			
Low Intensity Commercial			
High Intensity Commercial			
Light Industrial			
Highway			

<b>Land Use</b>	<b>Total area</b>	<b>Non-DCIA CN</b>	<b>DCIA percentage</b>
Natural Vegetated Community			
<b>Post-development</b>			
Low Density Residential			
Single Family			
Multi-Family			
Low Intensity Commercial			
High Intensity Commercial			
Light Industrial			
Highway			
Natural Vegetated Community			

As noted in [Section 1.3.1](#), Alachua County is in Rainfall Zone 2 and annually receives between 50 to 54 inches of rain (Figure 4.4). The Manual provides tabular solutions to a series of calculations for determining annual runoff volumes in Precipitation Zone 2.

Figure 4.4. Annual Rainfall Isoleths in Alachua County  
(Harper and Baker, ERD, June 2007)

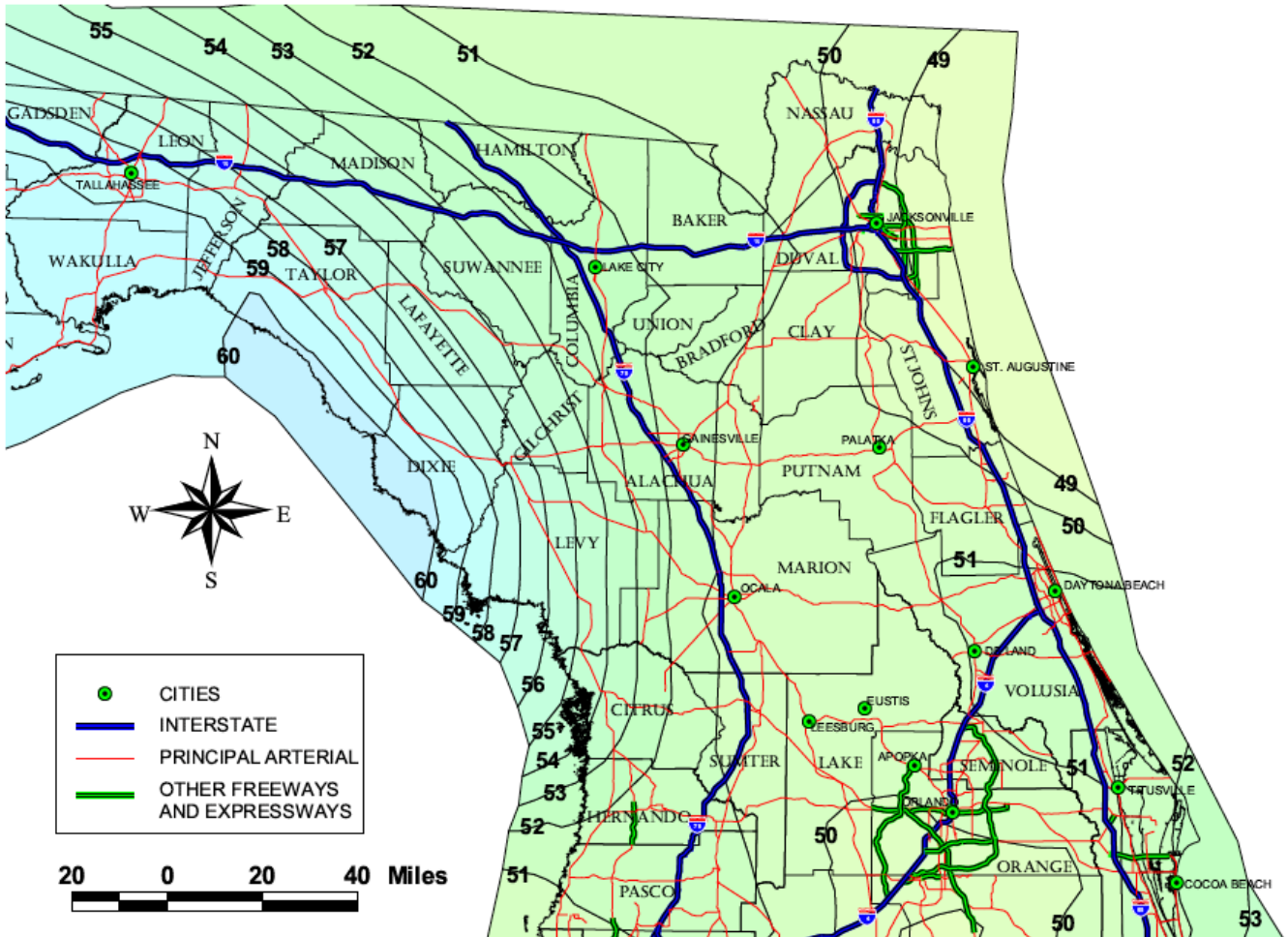

Table 4.3 below summarizes the calculated mean annual runoff coefficients (“C value”) as a function of Curve Number and Directly Connected Impervious Area (DCIA) in Precipitation Zone 2. These values reflect the average long-term runoff coefficients (C Values) over a wide range of DCIA and Curve Number combinations.

**Table 4.3. Mean Annual Runoff Coefficients (C Values) as a Function of DCIA Percentage and Non-DCIA Curve Number (CN) for Alachua County.**

Source: Harper and Baker, ERD, June 2007

NDCIA CN	Percent DCIA																				
	0	5	10	15	20	25	30	35	40	45	50	55	60	65	70	75	80	85	90	95	100
30	0.002	0.043	0.083	0.123	0.164	0.204	0.244	0.285	0.325	0.366	0.406	0.446	0.487	0.527	0.567	0.608	0.648	0.688	0.729	0.769	0.809
35	0.004	0.044	0.085	0.125	0.165	0.205	0.246	0.286	0.326	0.366	0.407	0.447	0.487	0.528	0.568	0.608	0.648	0.689	0.729	0.769	0.809
40	0.007	0.047	0.087	0.127	0.167	0.207	0.248	0.288	0.328	0.368	0.408	0.448	0.488	0.528	0.569	0.609	0.649	0.689	0.729	0.769	0.809
45	0.010	0.050	0.090	0.130	0.170	0.210	0.250	0.290	0.330	0.370	0.410	0.450	0.490	0.530	0.570	0.610	0.650	0.690	0.729	0.769	0.809
50	0.015	0.055	0.095	0.134	0.174	0.214	0.254	0.293	0.333	0.373	0.412	0.452	0.492	0.531	0.571	0.611	0.651	0.690	0.730	0.770	0.809
55	0.022	0.061	0.101	0.140	0.179	0.219	0.258	0.298	0.337	0.376	0.416	0.455	0.494	0.534	0.573	0.613	0.652	0.691	0.731	0.770	0.809
60	0.030	0.069	0.108	0.147	0.186	0.225	0.264	0.303	0.342	0.381	0.420	0.459	0.498	0.527	0.576	0.615	0.654	0.693	0.731	0.770	0.809
65	0.042	0.080	0.119	0.157	0.195	0.234	0.272	0.311	0.349	0.387	0.426	0.464	0.502	0.541	0.579	0.618	0.656	0.694	0.733	0.771	0.809
70	0.057	0.095	0.133	0.170	0.208	0.245	0.283	0.321	0.358	0.396	0.433	0.471	0.509	0.546	0.584	0.621	0.659	0.697	0.734	0.772	0.809
75	0.079	0.116	0.152	0.189	0.225	0.262	0.298	0.335	0.371	0.408	0.444	0.481	0.517	0.554	0.590	0.627	0.663	0.700	0.736	0.773	0.809
80	0.111	0.146	0.181	0.216	0.251	0.285	0.320	0.355	0.390	0.425	0.460	0.495	0.530	0.565	0.600	0.635	0.670	0.705	0.740	0.774	0.809
85	0.160	0.192	0.225	0.257	0.290	0.322	0.355	0.387	0.420	0.452	0.485	0.517	0.550	0.582	0.614	0.647	0.679	0.712	0.744	0.777	0.809
90	0.242	0.270	0.299	0.327	0.355	0.384	0.412	0.440	0.469	0.497	0.526	0.554	0.582	0.611	0.639	0.667	0.696	0.724	0.753	0.781	0.809
95	0.404	0.424	0.444	0.464	0.485	0.505	0.525	0.546	0.566	0.586	0.606	0.627	0.647	0.667	0.688	0.708	0.728	0.749	0.769	0.789	0.809
98	0.595	0.605	0.616	0.627	0.638	0.648	0.659	0.670	0.680	0.691	0.702	0.713	0.723	0.734	0.745	0.756	0.766	0.777	0.788	0.799	0.809

The information contained in Table 4.3 is used to estimate the annual runoff volume for a given parcel under either pre- or post-development conditions. The mean annual rainfall depth (52”) is multiplied by the appropriate mean annual runoff coefficient (C value) based upon the DCIA and Curve Number characteristics of the site as follows:

**Equation 4.6.1** Annual Runoff Volume (ac-ft.) =

$$Area \text{ (acres)} \times Mean \text{ Annual Rainfall (inches)} \times C \text{ Value} \times \frac{1 \text{ ft}}{12 \text{ in}}$$

Linear interpolation can be used to estimate annual runoff coefficients for combinations of DCIA and Curve Numbers that fall between the values in the Table. For “naturally occurring” undeveloped conditions, it should be assumed that the percent DCIA is equal to 0.0.

**4.6.2. Calculation of Pre-Development (Current) Stormwater Pollutant Loading**

To calculate the [pre-development](#) annual mass loadings of total phosphorus and total nitrogen, multiply the pre-development annual runoff volume (derived in Section 4.6.1) by the land use specific runoff characterization data ([event mean concentrations](#) or EMCs) for total phosphorus and total nitrogen. Florida specific EMCs are listed in Table 4.4 for several different types of pre-development and post-development land use categories. These are from the State of Florida EMC data base.

<b>Table 4.4. Stormwater Pollutant Loading Input Data</b>						
<i>Annual Rainfall</i>	<i>50 – 54” - Rainfall Zone 2 for BMPTRAINS Model</i>					
<b>Stormwater Event Mean Concentrations (mg/l)</b>						
<b>Land Use Category</b>	<b>Total N</b>	<b>Total P</b>	<b>BOD</b>	<b>TSS</b>	<b>Copper</b>	<b>Zinc</b>
Low Density Residential <sup>1</sup>	1.60	0.1370	5.25	25.75	0.010	0.036
Single Family	2.07	0.327	7.90	37.50	0.016	0.062
Multi-Family	2.32	0.520	11.30	77.90	0.009	0.086
Low Intensity Commercial	1.13	0.188	7.60	59.90	0.017	0.083
High Intensity Commercial	2.40	0.345	11.30	69.70	0.015	0.160
Light Industrial	1.20	0.260	7.60	60.00	0.003	0.057
Highway	1.52	0.200	5.20	46.00	0.025	0.116
Natural – Dry Prairie	2.025	0.184				
Natural – Marl Prairie	0.684	0.012				
Natural - Wet Prairie	1.095	0.015				
Natural – Mesic Flatwoods	1.09	0.043				
Natural – Scrubby Flatwoods	1.155	0.027				
Natural – Wet Flatwoods	1.095	0.015				
Natural – Upland Mixed Forest	0.606	1.166				
Natural – Upland Hardwood Forest	1.042	0.346				
Natural – Ruderal Upland Pine	1.694	0.162				
Natural – Xeric Scrub	1.596	0.156				
Range land/park land	1.15	0.055	1.40	8.40		
General Agricultural	2.80	0.487	3.80	34.20	0.012	0.021
Pasture	3.51	0.686	5.10	67.10		
Citrus	2.24	0.183	2.60	15.50	0.003	0.012
Row Crops	2.65	0.593		19.80	0.022	0.030
Conventional rooftops	1.05	0.12				
1. Average of single-family and undeveloped values						



The mass loading calculation is provided in Equation 4.6.2 below.

**Equation 4.6.2.** Annual Mass Loading = Annual Runoff Volume x EMC

The various components of Equation 4.6.2 are expressed in different units and require some conversion factors, as provided below.

Annual Mass Loading (lb./year) =

$$\text{Annual Runoff Volume (ac-ft./year)} * 43,560 \text{ ft}^2/\text{ac} * 7.48 \text{ gal}/\text{ft}^3 * 3.785 \text{ liter}/\text{gal} * \text{EMC (mg/l)} * 1 \text{ lb.}/453,592 \text{ mg}$$

**4.6.3. Calculation of Post-Development Stormwater Pollutant Loading**

Calculate the [post-development](#) annual mass loadings of total phosphorus and total nitrogen in a manner similar to the pre-development loadings above. Simply multiply the post-development annual runoff volume (derived in Section 4.6.1) by the land use specific runoff pollutant ondata (EMCs) for total phosphorus and total nitrogen listed in Table 4.4 for post-development land use conditions. The mass loading calculation is done using Equation 4.6.2.

**4.7. Designing the BMP Treatment Train to Meet Required Load Reductions**

Once the pre-development and post-development loadings have been calculated and the required percent reduction of TN and TP have been established, the stormwater [BMP treatment train](#) can be designed. This Manual includes a variety of BMPs, both nonstructural and structural, that can be used to reduce nutrients and other pollutants in stormwater discharges to either surface waters or ground waters. [Stormwater treatment systems](#) are generally most effective when designed to include a combination of BMPs in series to achieve the required pollutant removal efficiency. This concept is called the “BMP Treatment Train.”

Treatment efficiencies of BMPs in series must account for the reduced loading transferred to subsequent downstream treatment devices. After treatment occurs in the first system, a load reduction has occurred which is a function of the type of BMP used to provide treatment. After load reduction in the initial BMP, the remaining load consists of pollutant mass that was not removed. This mass is then treated by the second BMP with the nutrient reduction efficiency determined by the specific type of BMP used.

To obtain an overall increase in pollutant load reduction in a BMP Treatment Train, **the BMPs must be complementary and not duplicative with respect to the types of pollutants removed.** Upstream BMPs must not reduce the treatment effectiveness of the downstream BMP. For example, using BMPs that remove solids and particulate pollutants in front of a wet detention system will reduce the treatment effectiveness of the wet detention system. This is because most treatment in a wet detention system is a result of particle settling

The overall treatment effectiveness of two BMPs in series is calculated with Equation 4.7.1:

**Equation 4.7.1**

$$\% \text{ Removal} = \text{Eff1} + (1 - \text{Eff1}) * \text{Eff2} \dots$$

Where: Eff1 = efficiency of first treatment BMP

Eff2 = efficiency of second treatment BMP

As stormwater pollutant concentrations or stormwater volumes are reduced in each BMP in the treatment train, the ability of a BMP to further reduce stormwater pollutant concentrations and loads is diminished. The treatment efficiency used for downstream BMPs must account for the diminishing effectiveness of stormwater treatment.

Typically, to design your BMP system, first select the BMPs that will be used to meet the required TP load reductions. Once the BMPs for TP load reductions are selected, determine if the BMPs used also will achieve the required level of TN load reduction. Typically, retention systems will achieve the same load reduction for both TN and TP since their treatment effectiveness is directly related to the percentage of the annual stormwater volume that is retained on-site (aka captured volume). However, the typical load reduction for TN and TP vary greatly in BMPs that reduce pollutant concentrations as with sorption media or wet detention. If the TN and TP performance standards are met, complete the design of the stormwater treatment system. If they are not met, either modify the selected BMPs or add BMPs to increase the pounds of removal until the system meets the required amount of load reduction for both TP and TN.

#### 4.8. Computational Aids

Since LID BMPs may not be considered by the WMDs to be “presumptive” BMPs, a significant amount of information is needed in the permit application process to document the BMP design criteria and the relationship to pollutant load reduction. To obtain a permit for a stormwater system an applicant must include pre-development and post-development pollutant loadings. This is relatively easy to understand and many models can calculate such loadings. However, the difficulty is in calculating the stormwater treatment effectiveness (reduction in average annual TN and TP loadings) associated with the specific design criteria for the LID BMPs being used.

To assist designers in determining the pollutant load reduction effectiveness of proposed stormwater BMP Treatment Trains that incorporate LID BMPs, the University of Central Florida Stormwater Management Academy has created the **BMPTRAINS Model** software. This spreadsheet model is in the Public Domain and is available online for free at

<https://stormwater.ucf.edu/>

This software has been developed in cooperation with the FDEP, the WMDs, and the Florida DOT. It is accepted by FDEP and the WMDs for ERP permit applications. Its uniqueness is the inclusion of Florida specific data that are used to calculate the treatment effectiveness of LID BMPs, both individually and when they are used in either parallel or serial BMP Treatment Trains. It includes long term Florida rainfall data by zones and locations; Florida soils and their infiltration capabilities; Florida EMCs; Florida BMP effectiveness data; and Florida LID design criteria and effectiveness data. The BMP treatment effectiveness is based on the Florida BMP research and monitoring done over the past 30 years. This includes all the LID BMP effectiveness research and monitoring data. However, other continuous simulation methods, such as EPA SWMM or other public or proprietary software approved by the County, may also be used to calculate pre-development and post-development hydrology and loadings, providing Florida based rainfall, runoff, and loading data are used relative to good practice.

#### 4.9. References

Harper, H. H. and D. Baker. 2007. [Evaluation of Current Stormwater Design Criteria within the State of Florida](#). Final report submitted to the FDEP, June 2007.

Wanielista, Marty, Harvey Harper, Eric Livingston, Mike Hardin, Przemyslaw Kuzlo, and Ikiensinma Gogo-Abita, UCF Stormwater Management Academy, 2016. [User's Manual for the BMPTRAINS Model.](#)

# ALACHUA COUNTY STORMWATER MANAGEMENT MANUAL



## PART C

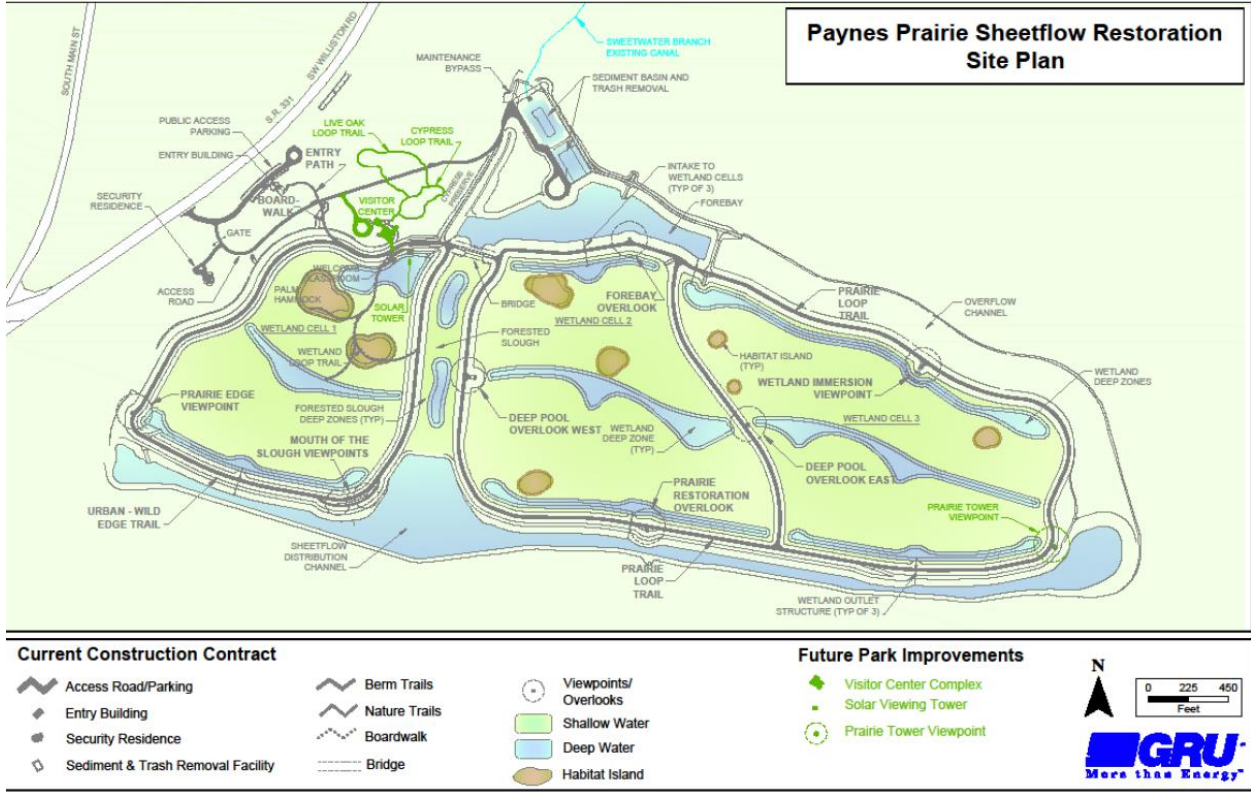

From: Paynes Prairie Sheetflow Restoration Project presentation, Alice Rankeillor, P.E. GRU, 2015

# CHAPTER 5. CATALOG OF STORMWATER BEST MANAGEMENT PRACTICES

## 5.0. Best Management Practices

### 5.0.1. Introduction to BMPs

This section of the Manual sets forth technical criteria for the design, construction, operation, and maintenance of [stormwater treatment systems](#) or [BMPs](#). These systems can be used, typically in combination as part of a [BMP Treatment Train](#), to achieve the Manual's required minimum levels of pollutant load reduction in [Section 4.3](#). As seen in Table 5.1, the BMPs are separated into three "phases" roughly parallel to key phases of land development and stormwater planning: site planning BMPs, source control BMPs, and stormwater treatment BMPs.

Each structural BMP section in Chapter 5 begins with a summary table that highlights the most critical information for the specific BMP covered in that section. The following information is included in these summary tables:

- Advantages/Benefits
- Disadvantages/Limitation
- Volume Reduction Potential
- Pollutant Removal Potential
- Key Design Considerations
- Key Construction and Maintenance Considerations

Criteria provided in Chapter 5 are considered minimum standards for the design of stormwater treatment systems in Alachua County. It is unlikely that any single BMP will achieve the WMD and Alachua County stormwater management objectives and it is intended that these BMPs will be implemented in series with other BMPs—a BMP treatment train approach. The stormwater treatment system should be designed so that the entire system meets minimum stormwater control requirements. It is important that users of this manual consult with the applicable WMD Environmental Resource Permitting criteria and the County's/City's guidance documents on land development and stormwater management, including the applicable Comprehensive Plan, Land Development Code, and the Code of Ordinances, for any variations to these criteria or additional standards that must be followed.

The BMPs in this Manual provide a wide range of average annual TN and TP load reductions. **In general, retention BMPs provide the greatest level of pollutant load reduction because they reduce the annual stormwater volume discharged off-site. The treatment effectiveness of retention BMPs is directly proportional to the percentage of the annual stormwater volume that is captured and retained on-site.** [Tables B1-1](#) and [B2-1](#), which are in Appendix B, provide the range of pollutant load reduction associated with retaining a specific volume of stormwater under varying conditions of the percent DCIA and the non-DCIA Curve Number. For example, Table B1-1 shows that the stormwater volume needed to achieve 80% average annual load reduction varies from 0.22 inches to 1.43 inches. Likewise, Table B2-1,



which contains a series of tables based on the stormwater treatment depth, shows that the average annual load reduction for a retention system with 0.5” treatment volume varies from 28.1% to 91.8% depending on a site’s CN and percent DCIA.

The effectiveness of [wet detention systems](#) varies depending on the average annual residence time as shown in [Figures 5.12.2](#) (TP) and [5.12.3](#) (TN). In general, a wet detention system can achieve a 30% to 43% reduction in TN and a 45% to 85% reduction in TP. To increase the effectiveness of a wet detention system, one can add [Managed Aquatic Plants](#) or an [Up-flow Filter](#) to reduce pollutant concentrations, or add a [stormwater harvesting system](#) that takes water from the wet detention system and uses it for non-potable purposes, thereby reducing the stormwater volume and pollutant loading discharged by the wet detention system.

To facilitate the design of BMP Treatment Trains that incorporate LID strategies and BMPs, this Manual includes the Stormwater BMP Strategies Checklist (Table 5.1). The BMP checklist is separated into three “phases” roughly parallel to key phases of land development and stormwater planning: conceptual site planning BMPs, source control BMPs, and stormwater BMPs. Those BMPs that have [a quantifiable nutrient load reduction](#) are shown in the last column.

**Table 5.1. Stormwater BMP Strategies Checklist**

Site Planning BMPs	Conceptual Site Planning	Completed or Used	N/A	Load Reduction Credit
<a href="#">SP1</a>	Inventory Site Assets: Hydrology			
<a href="#">SP2</a>	Inventory Site Assets: Topography			
<a href="#">SP3</a>	Inventory Site Assets: Soils			
<a href="#">SP4</a>	Inventory Site Assets: Vegetation			
<a href="#">SP5</a>	Protect Surface Waters and Wetlands			
<a href="#">SP6</a>	Preserve Open Space			
<a href="#">SP7</a>	Natural Area Conservation - Retain Tree Canopy and Native Landscapes			√
<a href="#">SP8</a>	Cluster Design and Maximize Gross Density			
<a href="#">SP9</a>	Minimize Building Footprint			
<a href="#">SP10</a>	Minimize Total Impervious Area			√
<a href="#">SP11</a>	Minimize Directly-Connected Impervious Area			√
<a href="#">SP12</a>	Curb Elimination and Curb Cuts			

Source Control BMPs	Source Control Techniques	Completed or Used	N/A	Load Reduction Credit
<a href="#">SC1</a>	Retain Natural Landscape Depressions			
<a href="#">SC2</a>	Minimize Clearing and Grading			
<a href="#">SC3</a>	Minimize Soil Disturbance and Compaction			
<a href="#">SC4</a>	Build with Landscape Slope			
<a href="#">SC5</a>	Retain Native Landscapes at the Lot Level			
<a href="#">SC6</a>	Florida-friendly Landscapes and Fertilizers			√
<a href="#">SC7</a>	Rainfall Interceptor Trees			√
<a href="#">SC8</a>	Install Efficient Irrigation Systems			
<a href="#">SC9</a>	Use Non-potable Water Supply for Irrigation			
<a href="#">SC10</a>	Community and Home Owner Education			
Structural BMPs	Structural Stormwater BMPs	Completed or Used	N/A	Load Reduction Credit
<a href="#">SW1</a>	Retention Basin			√
<a href="#">SW2</a>	Exfiltration Trench			√
<a href="#">SW3</a>	Underground Storage and Retention			√
<a href="#">SW4</a>	Rain Gardens			√
<a href="#">SW5</a>	Treatment Swales			√
<a href="#">SW6</a>	Vegetate Natural Buffers			√
<a href="#">SW7</a>	Pervious Pavements			√
<a href="#">SW8</a>	Green Roofs with Cisterns			√
<a href="#">SW9</a>	Rainwater Harvesting/Cisterns			√
<a href="#">SW10</a>	Wet Detention Systems			√
<a href="#">SW11</a>	Stormwater Harvesting/ Horizontal Wells			√
<a href="#">SW12</a>	Filter Systems			√
<a href="#">SW13</a>	Managed Aquatic Plant Systems			√
<a href="#">SW14</a>	Biofiltration Systems/Tree Box Filters			√

## 5.1. Site Planning BMPs

Site Planning BMPs are applied as part of the development design process to ensure efficient land usage and preservation of the site's natural hydrology. The following 12 Site Planning BMPs should be considered for each project. These site planning principles are associated with Smart Growth practices. Additional information pertaining to sustainable site planning may be found at [www.epa.gov/smartgrowth](http://www.epa.gov/smartgrowth).

The first step in using the Site Planning BMPs is to know what land and water resources are on the project site. To help conduct the inventory of Site Assets you can use the Environmental Resources Assessment Checklist in [Figure 2.4 or a similar form](#).

### SP1. Inventory Site Assets: Hydrology

Identify and retain the [pre-development](#) hydrology to the maximum extent possible, including natural flow/conveyance paths and patterns and drainage features. Maintain or replicate original site hydrology by preserving pre-development stormwater volume, infiltration, and evapotranspiration rates and the hydrologic assets of the site. When assessing a site for LID opportunities, it is important to identify and understand the stormwater sources and sinks in each catchment and sub-catchment, and plan accordingly.



Does runoff leave the site through surface or subsurface drainage? Is there potential for sinkhole formation or stream bank erosion? Although sinkholes form naturally, concentrating flow in a small area or increased pressure from storing large volumes of stormwater can accelerate the process. Both peak and total volume of runoff can contribute to erosion.

Are there adjacent land uses or sites that will contribute additional stormwater runoff or pollutant loads that will need to be addressed? In this phase of planning, the need for buffer strips or other strategies to protect sensitive areas (water bodies, karst features, desirable wildlife or cultural areas) in or adjacent to your site should also be identified.

### SP2. Inventory Site Assets: Topography

The pre-development topography should drive the stormwater design of a project as much as possible, rather than alter the topography of the site during development to fit a traditional stormwater management plan. Use the topographic characteristics of the site to guide the road layout and stormwater conveyance features, and consider the natural drainage patterns when delineating lots and placing public infrastructure. Topographic features should also guide lot-level landscape layout and plantings. For instance, avoid re-contouring and installing high-maintenance landscaping or turf, or disturbing areas with steep slopes or natural landscape depressions that should be preserved for their infiltration capacity. Natural depressions should be maintained where possible to promote storage, infiltration, and treatment during typical stormwater events and to capture part of the treatment volume during extreme events. However, increasing the volume of stormwater into natural depressions requires geotechnical investigation to safely store the runoff and minimize the formation of sinkholes.

**SP3. Inventory Site Assets: Soils**

Inventory and delineate the extent of all soil types present on site. Determine their [hydrologic group classifications](#) and capacity for stormwater infiltration. Clearly mark on drawings and designate on site all areas that will be vegetated or used in stormwater management to prevent their compaction and maintain the soil infiltration capacity. Consider any significant differences in infiltration potential when planning and laying out the proposed development. Employ careful site clearing, grading, equipment and materials staging when planning construction to limit compaction and protect native soil characteristics.

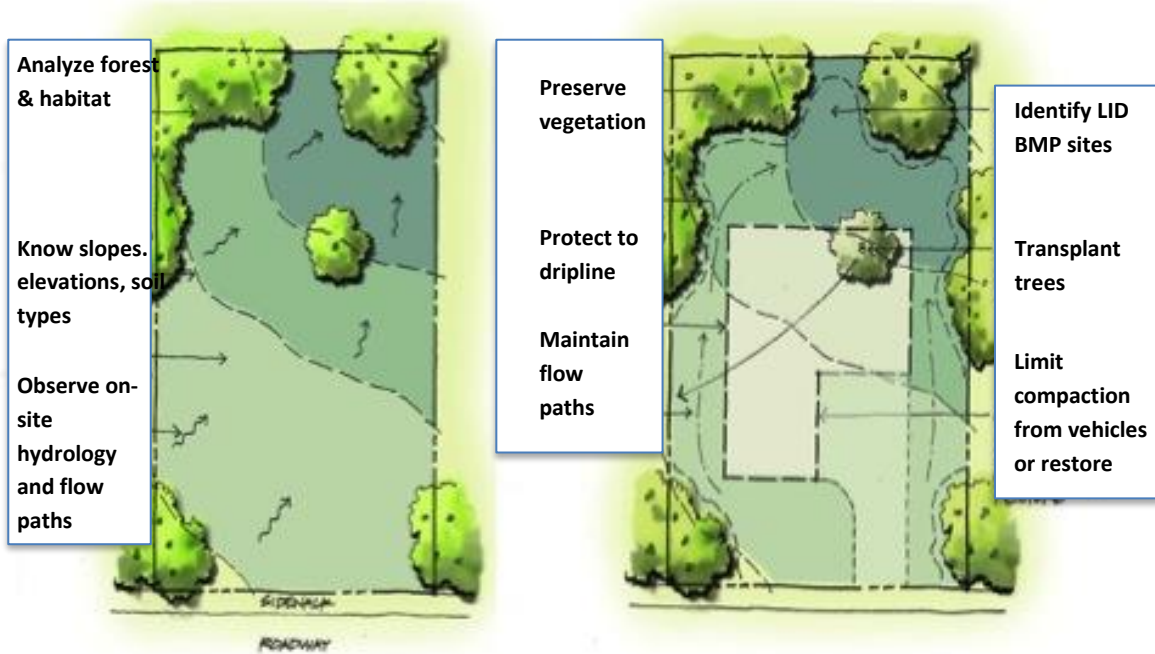

Consider site vegetation and topography, maintain natural hydrology, and limit soil compaction.

**SP4. Inventory Site Assets: Vegetation**

Protection of trees and native vegetation promotes carbon dioxide absorption, oxygen production, dust filtration, reduction of wind, noise, and glare, soil stabilization and enrichment, erosion prevention, surface drainage improvement and aquifer recharge, water pollution reduction, wildlife habitat, energy conservation, temperature moderation, the economic enhancement of improved and vacant lands, scenic beauty, quality of life, and the health, safety, welfare and well-being of the community.

Check the applicable County/City Comprehensive Plan or Land Development Code to determine requirements for tree inventory and preservation, tree removal, removal of native vegetation, removal of exotic plants, and landscaping.

### SP5. Protect Surface Waters and Wetlands

Surface waters is a comprehensive term that includes all rivers, streams, creeks, springs, lakes, ponds, intermittent water courses and associated wetlands that hold or transport water on the ground surface. Protect surface waters and wetland edges by using buffers and native plantings. Check the applicable County/City Comprehensive Plan or Land Development Code to determine requirements.

For example, within unincorporated Alachua County, Article 406.43, Water Resources Buffers, of the ULDC requires buffers around surface waters or wetlands to be maintained by retaining existing, undisturbed vegetation. The appropriate width of the buffer is determined on a case-by-case basis following a site inspection by the County. Among the factors considered are the potential for adverse impacts both on-site and off-site, the type of water to be protected and plant and animal communities present. Minimum buffer distance varies by the type of surface water: they are at least a minimum of 35 feet and an average of 50 feet for waters less than 0.5 acre and no special designation, and go up to a minimum of 100 feet with an average of 150 feet for Outstanding Florida Waters. In addition, properties bordering large constructed wet detention basins should have non-turf native plantings on the water's edge of a minimum of 20 feet.

Finally, [Appendix A](#) lists the receiving waters within Alachua County for which FDEP has established a [WBID number](#). Within the table, those waters that are not meeting their applicable water quality standards ([Verified Impaired Waters](#)) or for which a [Total Maximum Daily Load](#) or [Basin Management Action Plan](#) has been adopted are identified. Any project that will contribute pollutant loads to these impaired water bodies must meet the "[Net Improvement](#)" performance standard for stormwater treatment.

### SP6. Preserve Open Space

Once a thorough inventory of the site assets that facilitate LID BMPs has been completed, the first planning strategy is to preserve these assets to the maximum extent possible. Consider all areas where [open space](#) and [pervious areas](#) can be protected. Check the applicable County/City Comprehensive Plan or Land Development Code to determine requirements.

Not all sites contain significant amounts of natural vegetation that can be preserved, but where they exist, several established ecological principles should be considered when initially laying out development and setting aside open spaces.

- The objective is to reduce the length of edges between the development and natural area. Edges have greater disturbance, more predators, and poorer habitat for many species. The width of an edge varies by species, but can extend 150-300 feet into a patch of habitat.
- The shape of natural areas is important for minimizing the effects of development on many plants and animals. Therefore, one 15-acre natural area is much better than five three-acre natural areas. Similarly, a roughly circular shape has a shorter perimeter than a long narrow or irregularly shaped site with the same area.
- Patches with "soft" edges (gradual & undulating vegetation) are better than those with "hard" edges (straight & sudden)
- It is not always possible to design a natural area with inland areas free of edge effects. However, any open space is better than none, as some species will still benefit despite edge effects.



- Where there are several patches of natural habitat, connecting them with a corridor is desirable. Wide corridors are better than narrow, and natural corridors are better than man-made.
- If both exist on site, wet *and* dry areas should be included in a preserved area.
- Preserve rare natural communities over more common ones, using the Florida Natural Areas Inventory state and global rarity ranking.

**SP7. Natural Area Conservation - Retain Tree Canopy and Natural Landscaping**

Tree canopy can be viewed as the first line of defense in stormwater source control. Retaining native and large tree canopies to the maximum extent possible and planning new tree plantings to maximize tree canopy over the life of the project will help retain and enhance pre-



*Trees were retained at this site, but avoid mounding soil around the base of the trees, as they did here!*

development interception and evapotranspiration capacity, reducing generation of stormwater runoff. There is evidence that tree canopies have the potential to intercept approximately 15-20% of the water in a storm event that falls on their leaves. This water is retained by surface tension and reduces the potential for runoff from impervious surfaces directly underneath the canopy.

Tree canopies retain rain water on leaves via surface tension (up to 15% of the water that falls on the canopy), a virtual “retention pond in the sky.” Consult [Section SC7](#) of this Manual for Interceptor Tree BMP design criteria that provide stormwater credits for retaining large

native trees on site or for reforesting portions of a site. Silva cell technology for soil porosity provides protection under foot-travel paved areas and allows for regular tree root growth.

Position or plant trees so that when they are fully grown (10-40 yrs., depending on species) they will [cover impervious surfaces](#) or shade buildings during the summer months from noon to late afternoon. Use deciduous trees when and where appropriate to provide shade in the summer months and maximize solar gain during the winter months. Maximize the amount of tree canopy cover over impervious surfaces to get stormwater credit for using Interceptor Trees.

Raising or lowering the grade level around trees, by even a few inches can kill the tree. Lowering the grade is likely to remove important root mass, while raising it can prevent oxygen from reaching the roots, smothering them.

**Natural Area Conservation Pollutant Load Reduction Credit:** Protection of natural areas and their associated vegetation helps maintain the undeveloped hydrology of a site by reducing runoff, promoting infiltration and preventing soil erosion. The undisturbed soils and native vegetation of conservation areas promote rainfall interception and storage, infiltration, runoff filtering and direct uptake of pollutants. Natural areas are eligible for stormwater credit if they remain undisturbed during construction and are protected by a permanent conservation easement prescribing allowable uses and activities on the parcel and preventing future development. Examples of conservation areas include any areas of undisturbed vegetation



preserved at the development site, such as forests, floodplains and riparian areas, steep slopes, and stream, wetland and shoreline buffers.

#### 1. Calculation of Stormwater Treatment Credit

Natural areas that are placed into conservation shall be excluded from the runoff calculations used to determine the volume of stormwater that must be treated or to calculate pre- and post-development nutrient loads.

#### 2. Conditions for Credit

Proposed conservation areas shall meet the conditions outlined below to be eligible for credit:

- The minimum combined area of all of the natural areas conserved at the site must exceed one acre.
- No disturbance may occur in the conservation area during or after construction (i.e., no clearing or grading except for restoration operations or removal of exotic vegetation unless provided for within the conservation easement).
- The limits of disturbance around each conservation area shall be clearly shown on all construction or permit drawings.
- A long-term vegetation management plan must be prepared to maintain the conservation area in a natural vegetative condition. Managed turf is not considered an acceptable form of vegetation management, and only the passive recreational areas of dedicated parkland are eligible for the credit (e.g., ball fields and golf courses are not eligible).
- The conservation area must be protected by a perpetual easement that is filed in the public records prior to beginning construction.

### **SP8. Cluster Design and Maximize Gross Density**

The terms “clustering” and “high density” are sometimes equated, but high density design may be perceived and portrayed as contrary to smart growth principles. However, both are useful strategies from an LID design perspective.

Clustering of built infrastructure at the development or subdivision scale is a preferred technique that can significantly reduce the overall environmental impacts of a project. This strategy is useful primarily for residential and mixed-use developments. Cluster design typically reduces the length of roads (and therefore transportation infrastructure costs as well), total impervious area and area needed for stormwater management infrastructure, and reduces overall site disturbance. It also allows the opportunity in project design to maintain natural areas and wildlife habitat.

Another important, yet simple LID strategy to consider (also particularly for residential subdivisions or mixed-use developments) is maximizing gross density by designing for smaller lots. Alachua County is encouraging this type of LID design by using gross density rather than lot size requirements where possible. This approach does not reduce the total number of permitted units per acre and provides the design engineer flexibility in planning to protect the most ecologically sensitive and valuable portions of a site. By reducing the total project impact, the use of both clustering and smaller lot sizes (in some cases) may allow the developer to increase the total number of developed units or lots, thereby increasing total project revenues.

For example, clustering to increase density from 1 unit/acre to 4 units/acre, while maintaining the same total number of units, has been estimated to reduce the average annual stormwater runoff for the total site by 67% (EPA, 2006). Therefore, the total stormwater runoff from the entire site will be reduced, even though runoff from the more densely developed portion of the site may increase. Furthermore, other benefits of clustering extend well beyond reducing stormwater runoff volumes and loads.

For a discussion of high- vs. low-density developments and detailed information on the water quality benefits of compact development, see EPA's *Protecting Water Resources with Higher Density Development* (2006) at [www.epa.gov/smartgrowth](http://www.epa.gov/smartgrowth).

**SP9. Minimize Building Footprint**

To reduce the impervious footprint of the project and disturbance of the site, consider multi-story building design options for the project (i.e., build vertically). Buildings with more than one story maximize the square footage to area ratio and lessen the stormwater runoff from the site.



On sloping sites, rather than importing fill to make a level site for slab-on-grade foundations, use stem-wall construction and minimize the area disturbed and compacted. Fill material in Florida, usually has a significantly different composition from native soils, particularly in the potential for phosphorus leaching. In the example illustrated, the pH of fill material was 7.3 vs. 5 in native soil, and leachable P was on the order of 50 to 100 times as great.



### SP10. Minimize Total Impervious Surface Area

Minimizing [total impervious surface](#) area reduces the [post-development](#) stormwater volume and peak discharge rate. There are many design options to minimize total impervious surface area, thereby increasing the potential for infiltration of stormwater particularly with street and parking design. Street design should look for a layout that reduces the total street length; curvilinear roads and short cul-de-sacs typically save 20-25% over a strict grid pattern. Narrower lots and cluster design maximize the number of lots per unit length of pavement. Neighborhoods that emphasize short, walkable streets offer efficient use of resources and structure that encourages desirable connected communities. Shared multi-use open space and easily accessible commercial areas are also features of this type of development.

Another way to reduce impervious pavement is to narrow street widths as much as possible. Narrow roads can be used for residential streets with traffic volume of 500 trips per day or less. Wider roads are often perceived to be safer, but narrow streets tend to cause drivers to slow down. Greater width encourages higher speed, which is the main cause of both pedestrian and vehicle accidents. Pervious pavements can be incorporated to provide wider access for emergency vehicles and on-street parking.

Check the applicable County/City Comprehensive Plan or Land Development Code to determine requirements. For example, in unincorporated Alachua County cul-de-sacs must provide the minimum turning radius needed for a 30 feet wheel base vehicle to make a 90-degree turn. The minimum radius is recommended. If a larger radius is required, using recessed center landscaped islands will reduce the amount of impervious area and provide for stormwater infiltration. In some designs cul-de-sacs may be replaced with T-shaped turn around or loop roads, which substantially reduce pavement.

Eliminate alleyways and paved auxiliary roads to the greatest extent possible. When auxiliary roads are necessary, use load-bearing pervious pavements or permeable pavers. Also reduce sidewalk widths and consider incorporating shared driveways to reduce impervious area. Sidewalks are usually not required on both sides of residential streets. As previously discussed, smaller lot sizes reduce street length; similarly, reduced setbacks from the roadway will shorten driveways and lessen paved areas. However, overall impact must be considered, as larger setbacks may be required to incorporate roadside swales.

Parking lots should be designed to use small parking space dimensions and the fewest number of parking spaces necessary. [Pervious pavement](#) can be used for many parking lots, especially for overflow parking (for seasonal or rare events). Maximize infiltration capacity of parking areas by using structurally-reinforced grass areas or pervious gravel areas for overflow parking. Where possible, design impervious areas to first drain into interior recessed rain garden islands with overflow directed via sheet flow across pervious areas to swales or finally a piped conveyance system.

### SP11. Minimize Directly-Connected Impervious Area (DCIA)

[Directly connected impervious areas](#) allow runoff to be conveyed without interception by permeable areas that allow for infiltration and treatment. Disconnecting impervious areas from roofs, small parking lots, courtyards, driveways, sidewalks and other impervious surfaces allows runoff to flow onto adjacent pervious areas where it is filtered or infiltrated. Reduce DCIAs by designing the site to divert sheet flow into a swale, infiltration basin, rain garden, vegetated natural buffer or pervious area for treatment. Disconnection of rooftops offers an excellent opportunity to harvest this rainwater and either reuse it or distribute it over lawns and other



pervious areas where it can be filtered and infiltrated. Downspout disconnection can infiltrate runoff, reduce runoff velocity, and remove pollutants. Alternately, downspouts can be directed to a cistern, rain barrel, dry well, rain garden or landscaped infiltration area (See SW9 [Rainwater Harvesting BMP](#)).

Use curb cuts or uncurbed roads that will drain to vegetated swales as a method to reduce directly-connected impervious areas (See [SP12](#)). To the greatest extent possible, drain parking lots to vegetated swales, exfiltration systems, or interior vegetated parking lot islands that have been designed as rain gardens. Incorporate underdrains or elevated culverts to protect against flooding.

At the project level, disconnection of impervious area can go a long way in reducing the need for costly stormwater conveyance and treatment infrastructure. Reduce the connectedness of impervious areas by treating the stormwater incrementally, close to the source of generation. Instead of gathering all stormwater runoff from parking areas and building roof and piping it to a large, centralized basin. Gather and treat the stormwater from each roof side into separate, small rain gardens on each side of the building. Again, pervious pavement should be considered for parking or drain runoff to vegetated areas where possible.

As seen in [Table 4.3](#), the required stormwater treatment volume is directly related to the amount of DCIA. Disconnecting small areas of impervious cover from the storm drain system can greatly reduce the total volume and rate of stormwater runoff. Credits for surface disconnection are subject to the restrictions below concerning the length, slope, soil characteristics of the pervious area which are designed to prevent any reconnection of runoff with the storm drain system. In some cases, minor grading of the site may be needed to promote overland flow and vegetative filtering.

**DCIA Stormwater Treatment Credit** - The total disconnected impervious area is moved from the DCIA calculations of stormwater treatment volume to the non-DCIA area when computing the stormwater treatment volume. This will reduce the stormwater volume which reduces the stormwater pollutant loading.

Conditions for Credit - For the purposes of the stormwater treatment rule, impervious area is disconnected if the following conditions apply for the overland flow of stormwater:

- The contributing impervious area is not more than 50% larger than the overland flow area.
- Non-directly connected impervious areas include all pervious areas and portions of impervious areas that flow over at least 10 feet of pervious areas with HSG A or B soils and over at least 20 feet of pervious area for other soil types.
- The roof runoff is diverted into a cistern, rain barrel, or other storage device where the water is reused for non-potable purposes (rainwater harvesting).
- The surface slope for overland flow must be between 0.5% and 5.0%.
- The velocity of runoff from a 5-year frequency storm must not exceed 0.15 feet per second.
- The infiltration capacity of soils in the overland flow path must be sufficient and not reduced by compaction, or amendment and tilling will be required to restore permeability.

Soil amendments, as discussed in the Filter Section, may be needed to restore porosity of compacted pervious areas. Soil amendments refer to tilling, composting, or other amendments to urban soils to recover soil porosity, increase water-holding capacity, and reduce runoff. Soils in many urban areas are highly compacted from prior grading, construction traffic and ongoing

soil disturbance. Amendments recover soil porosity by incorporating compost, top soil, and other soil conditioners to improve the hydrologic properties of lawns or landscaped areas

### SP12. Curb Elimination and Curb Cuts

**Intent:** Curbs and gutters have been standard features of stormwater management for roadways and parking lots, intercepting and directing runoff into drainage pipes in an efficient manner. However, they are often inconsistent with the goal of maintaining natural hydrology. Curbs concentrate runoff into faster flowing, more erosive streams of water. Simply eliminating curbs and allowing stormwater to sheet flow from roadways onto vegetated areas slows runoff and reduces peak discharge rates. If used in conjunction with downstream infiltration BMPs, total stormwater volume is reduced and stormwater pollutant loads are reduced.

If barriers are desired to bar vehicles from the shoulders of streets, curbs with cuts or raised semi-spherical knobs can be used for this purpose without obstructing the flow of stormwater.



*Curb cuts at Campus USA Headquarters in Alachua County allow runoff to flow into depressed island retention areas*

Curbs may also be desired to protect landscaped areas from pedestrian traffic in public locations. Pavement must be graded so that stormwater flows through the curb cuts onto the vegetated area. Thus, roadways and other paved areas can be changed from DCIA to non-DCIA areas, reducing the calculated required treatment volume.

If a site does not meet the criteria for non-DCIAs, the elimination of curbs or curb cuts, etc. can still be used to direct flow onto grassed verges, vegetated swales or rain gardens. Changing the traditional curb and gutter approach is a simple, very cost-effective method of stormwater management. It can easily be used to retrofit areas with existing curbs, by making cuts at low points in the curb to direct runoff onto other LID stormwater features.

**Design Considerations:** The first design decision is whether curbs are needed at all. In many residential communities, curbs are unnecessary. In commercial and other public areas, curbs are often desired to maintain proper traffic patterns. Tire stops can also serve this purpose

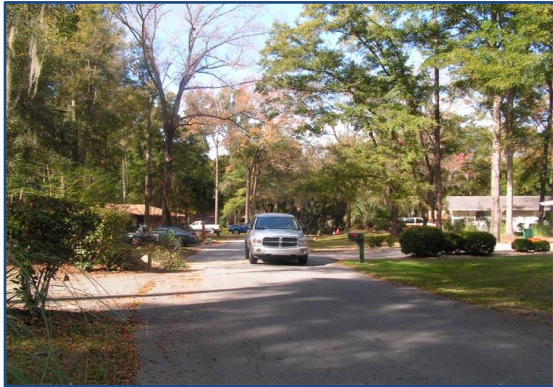

Think this...

instead of this.

If curbs are desired, eliminating stormwater inlets and piped conveyances can still be considered if runoff is directed to pervious areas through curb cuts. Whether gutters are required depends on how stormwater is being treated and managed downstream.

If curb cuts are used, their number, placement and design should be evaluated.

- An opening 18 inches wide is recommended to reduce the potential for clogging.
- The sides can be vertical or angled at 45 degrees.
- The bottom of the curb cut must slope away from the pavement.
- A 2" drop is recommended between the pavement and the vegetated area.
- Consider whether a concrete pad or gravel area is needed to dissipate energy and prevent erosion at entry points to rain gardens or parking lot islands.

Note, the street profile must match the intended drainage; i.e., a crowned street will drain to both sides, or a side shed profile will drain to only one side.

**Maintenance:** Inspections are required before the beginning of each rainy season (April-May) to check that runoff is flowing as intended, that curb cuts are not blocked by sediment, vegetation, or debris, and that soil in the downstream vegetated area is not being eroded.



## 5.2. SOURCE CONTROL BMPs

Often the most cost effective and simple stormwater volume and water quality goals are accomplished by managing rainfall and stormwater runoff at the source. **Source control techniques** can be defined as nonstructural BMPs that reduce the amount of stormwater that runs off a site (**volume source controls**), or act to lessen the nutrients and other pollutants that are picked up and carried by stormwater (**load source controls**). These can include many strategies ranging from disconnecting impervious areas to minimizing paved areas to education programs to teach homeowners to use less [Florida-friendly fertilizer](#) on their [Florida-friendly landscapes](#). Source controls are usually low cost, simple techniques that could be described as the “ounce of prevention” that is worth more than a “pound of cure.”

Typically, the most expensive elements of conventional stormwater systems are the conveyance and treatment structures, particularly as the physical distance from the source to a discharge point increases. When a site is proposed for development or redevelopment, the easiest way to maintain or restore the pre-development hydrology is to implement control measures as close as possible to the source. Suites of distributed, source control strategies at the lot or project level are the keystones of LID BMP treatment trains.

### SC1. Retain Natural Landscape Depressions

Natural depressions in the landscape are Mother Nature’s [retention](#) systems. They should be preserved where possible to promote storage, infiltration, and treatment of stormwater. Lot lines can be determined in part by location of natural depressions, and one or more per lot can be used to install rain gardens on individual lots. Again, remember to view these natural landscape depressions as LID assets and potential environmental and marketing (homeowner) amenities.

### SC2. Use Selective Site Clearing and Grading

To preserve the natural topography and avoid disturbing native soils, carefully plan clearing, grading, and construction. Then clearly delineate the areas on the ground and instruct all construction personnel on their purpose and importance. This will minimize soil compaction over the entire site - the ultimate goal being completely undisturbed soil in all areas except the building and impervious surface footprint. Use existing roads, future road areas, or previously compacted areas for materials staging.



### SC3. Minimize Soil Disturbance and Compaction

The fertility, infiltration capacity, extent of compaction and stability of native soils will constrain the landscape design and management plan to varying extents. All LID BMP projects should evaluate the likely impacts of development on site soils and attempt to minimize adverse impacts. This can be done through preservation and protection of planned

vegetated areas, and soils that will not be covered by impervious materials throughout the project to the maximum extent possible.

SOIL TYPE	INFILTRATION RATE (IN/HR)	
	PITT ET. AL. (Alabama)	GREGORY (Alachua County)
Sandy Soils	13.0	14.8 - 25
Compacted Sandy Soils	1.4	0.3 – 6.9
Clay Soils	9.8	NA
Compacted Clay Soils	0.2	NA

As demonstrated in the adjacent table, research on infiltration rates of sandy soils in North Florida has demonstrated that compaction reduces infiltration rates by between 80 and 99 percent by construction equipment ([Gregory, 2006](#)). This has a greater impact than

the soil classification in many cases, and stormwater runoff prediction may be significantly underestimated by ignoring the effects of compaction.

Compaction of the top 6 inches is primarily related to tire pressure, and compaction of greater depths is related to the total weight of the equipment, affecting primarily the top foot of soil, but some compaction continues up to 3 feet. The degree of compaction varies with the soil type, pH, the organic and mineral content and moisture level. The upper layers of sandy soil can recover in 4-9 years, but some soils with high clay content have taken more than 40 years to recover.

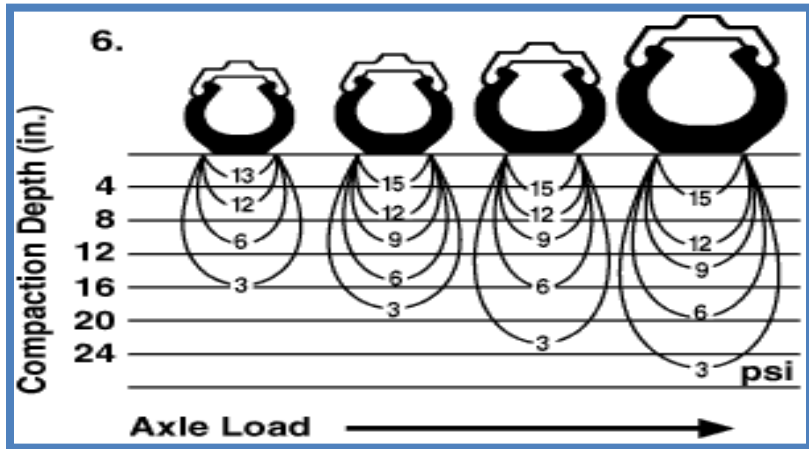

*Up to 80% of compaction occurs during the first pass of a vehicle!*

Remember that regardless of how well a structural infiltration-based BMP is designed, it will only achieve its design goals if the infiltration capacity of site soils meets design standards. Similarly, even the hardiest, drought-tolerant trees and plantings cannot thrive if the soils in which they are planted have been excessively compacted. Although soils disturbed during site preparation and construction should be amended with compost to restore some permeability and infiltration capacity, most soils cannot be returned to their natural state. Avoiding

compaction is far preferable and less expensive. It is imperative that sites intended for infiltration BMPs be clearly designated and not traversed by heavy construction equipment.

#### **SC4. Build with the Landscape Slope**

Retain the natural slope of the landscape by designing buildings and infrastructure around existing topography, rather than re-contouring the land to fit the building design. Build with the slope of the landscape by considering stem wall construction or pier and beam/raised floor foundations (rather than the traditional slab-on-grade) for homes and buildings. Raised floor construction without exterior fill on sloped sites reduces fill needs and lot-level soil disturbance.

#### **SC5. Retain Native Landscapes at the Lot Level**

Minimize the planned area requiring imported or constructed landscapes. Plant and maintain [Florida-friendly](#) or native vegetation wherever possible (i.e. celebrate Florida's native plant diversity). Minimize use of turf grass and use it only where outside active recreation is planned and frequent. Plant native vegetation in beds that will require little or no irrigation after establishment. Native trees and shrubs can be watered with temporary perforated hoses laid on top of the ground and covered by mulch. They do not need to be irrigated by permanent in-ground systems. Homeowners should be instructed to remove the hoses in approximately one year, after plants are established.

#### **SC6. Florida-friendly Landscaping™ and Fertilizers**

Recent studies have shown that nitrate levels are rising in many local water bodies, especially springs. Nitrate is a form of nitrogen that is found in inorganic fertilizers. Nitrogen is needed to help lawns stay healthy. When fertilizer is applied correctly, the grass will use all the nitrogen. If applied incorrectly, nitrogen can leach into our ground water or wash off the land and into lakes, rivers and the Gulf. Once in our water bodies, nutrients from fertilizer may cause algae to grow. Algae can form large blooms that shade out beneficial aquatic plants and use oxygen that fish need to survive.



Minimize new landscaped areas requiring supplemental inputs of fertilizer and irrigation by creating a Florida-friendly landscape (<http://www.floridayards.org/>). Plan your site for low-impact and resource-efficient landscapes that have the capacity to thrive without supplemental inputs of irrigation, fertilizers, pesticides, herbicides, etc. For the entire site, minimize the area of landscapes that require irrigation. Minimize turf lawns as needed for family activities or replace turf with Florida-friendly groundcovers and vegetation. Perennial peanut makes an excellent groundcover. Grasses are dormant during winter from about November until mid-March. Dormant grasses require little to no watering. Watering may be needed in April, May, and October since those months are usually dry. Irrigate in the hour before dawn to reduce water loss due to evaporation or wind. Irrigate only one or two days per week (as per current Water Management District watering regulations). Use rain monitors and/or soil moisture sensors to reduce unnecessary water use and regulate irrigation timers. Where possible, irrigate with non-potable water such as rainwater (See [Rainfall Harvesting BMP](#)),

stormwater (See [Stormwater Harvesting BMP](#)), or reclaimed water. However, if using reclaimed water be sure to find out the concentration of nitrogen and phosphorus in the reclaimed water and do not overwater. Overwatering will lead to stormwater coming off the landscape and create nutrient loading to downstream stormwater conveyances and water bodies. Overuse of reclaimed water can increase stormwater [EMCs](#) by 50%.

Be sure to use Florida-friendly fertilizers (<http://www.swfwmd.state.fl.us/yards/fertilizing/>) and download the [Do-It-Yourself Guide to Florida-friendly Fertilizing](#). The Florida Department of Agriculture and Consumer Services passed a rule ([Chapter 5E-1.003 F.A.C.](#)) regulating labeling requirements in Florida for urban turf fertilizers. The new labeling requirements will make it easier for homeowners to find lawn fertilizers with both slow-release nitrogen and low phosphorus. This rule is intended to reduce potential pollution that might result from application of excess fertilizer to lawns.

Florida-friendly Urban Turf Fertilizer Labeling Requirements:

Specialty Fertilizer products labeled for use on urban turf or lawns shall be no phosphate or low phosphate.

- “No phosphate” fertilizers shall contain less than 0.5% of available phosphate expressed as P<sub>2</sub>O<sub>5</sub>. The “grade” shall indicate a zero guarantee.
- Fertilizers labeled as low phosphate shall have use directions that do not exceed an application rate of 0.25 lbs. P<sub>2</sub>O<sub>5</sub>/1000 sq. ft. and not to exceed 0.50 lbs. P<sub>2</sub>O<sub>5</sub>/1000 sq. ft. per year.
- Fertilizers labeled as, or formulated for use as, starter fertilizer shall have use directions that do not exceed an application rate of 1.0 lb. of P<sub>2</sub>O<sub>5</sub>/1,000 sq. ft. and that subsequent applications shall be made with products meeting the definition of Low or No Phosphate fertilizers. The term “starter fertilizer” shall be part of the brand name

Fertilizers labeled as urban turf or lawn fertilizer shall have directions for use for nitrogen that:

- Are consistent with the annual nitrogen recommendations in the table below.
- Nitrogen shall not be applied at an application rate greater than 0.7 lbs. of readily available nitrogen per 1000 sq. ft. at any time based on the soluble fraction of formulated fertilizer.

<b>TURF SPECIES</b>	<b>Bahiagrass</b>	<b>Bermuda</b>	<b>Centipede</b>	<b>St. Augustine</b>	<b>Zoysia</b>
Timing of Application: Only apply fertilizer to actively growing turf (needs mowing at least once every two weeks)					
Maximum pounds of Nitrogen per fertilizer application					
Spring or summer	2	2	2	2	2
Fall or Winter	1	1	1	1	1
Maximum Annual Pounds	2-3	3-5	1-2	2-4	2-3



- Not more than 2 lbs. of total nitrogen per 1000 sq. ft. per application may be applied during the spring or summer;
- Not more than 1 lb. total nitrogen per 1000 sq. ft. per application may be applied during the fall or winter.
- If a total controlled release product is applied, not more than 35 percent of the nitrogen in the controlled release fertilizer can be released within the first 7 days after application.

**Stormwater Treatment Credit** – The Florida-friendly Landscaping™ and Fertilizers BMP is a provisional BMP that do not have sufficient data to be accepted by FDEP or the WMDs. Use this BMP pollutant load reduction credit to meet the additional 10% load reduction required by Alachua County for net improvement.

Residential developments designed in accordance with the principles of the Florida-friendly landscaping™ program, as set forth in Chapter 407, Article 4 – Landscaping of the ULDC, shall receive a three percent (3%) TN load reduction credit. Since this is a Source Control BMP that minimizes the amount of nitrogen and phosphorus fertilizer applied, the load reduction credit can be claimed first when performing nutrient loading calculations.

Conditions for Credit - A development project shall meet the conditions outlined below to qualify for the [Florida-friendly Landscaping™](#) stormwater treatment credit:

- The entire development project shall have all landscaping designed and constructed in accordance with the principles of the Florida-friendly landscaping™ program.
- The development shall implement and record deed restrictions and other restrictive covenants based on the [Model FYN Deed Restrictions and Restrictive Covenants](#).
- All fertilizers shall be “[Florida-friendly](#)” fertilizers and their application consistent with the requirements in [Chapter 78 – Fertilizer Standards and Management Practices](#) of the Alachua County Code of Ordinances.
- All commercial fertilizer applicators that apply fertilizers within the development shall have been trained in the [Florida Green Industry BMP Program](#) as required in Section [403.9338, F.S.](#), and certified pursuant to the requirements in [Section 482.1562, F.S.](#)
- The publication entitled *Do-It-Yourself Guide to Florida-friendly Fertilizing* shall be provided to each new buyer within the development.

**SC7. Rainfall Interceptor Trees**

**1. Description**

Interceptor trees are used in urban land uses adjacent to impervious surfaces as part of the stormwater treatment system to reduce runoff volume and pollution from the area. Trees intercept rain water and retain a significant volume of the captured water on their leaves and branches allowing for evaporation and providing runoff reduction benefits. This reduces stormwater volume and pollutant loading. For example, a large oak tree can



intercept and retain more than 500 to 1,000 gallons of rainfall in a year (Cappiella, 2004). While the most effective Interceptor Trees are large canopied evergreen trees, deciduous trees can

also provide a benefit. For example, a leafless Bradford pear will retain more than one half the amount of precipitation intercepted by an evergreen cork oak (Xiao et al., 2000). Interceptor trees are an important component of urban reforestation and therefore also help to reduce the heat island effect.

**INTERCEPTOR TREES SUMMARY**

Advantages/Benefits	Reduces stormwater volume by intercepting rainfall and preventing it from hitting impervious surfaces; reduces heat island effect; reduces potable water use and reuses stormwater for irrigation; can be used within parking lot islands; can be used for new trees or existing trees. Interceptor trees also provide for enhanced aesthetic value, provides shade to cool pavement and reduces surface runoff temperatures, aids in removal of air pollutants and noise reduction, and provides potential LEED Credits.
Disadvantages/Limitations	Trees must be within 15 feet of impervious area; must provide adequate uncompacted and aerated soils for tree survival.
Volume Reduction Potential	Low to Moderate depending on number of trees and canopy cover of impervious surfaces.
Pollutant Removal Potential	Low to Moderate, directly related to reduction in stormwater volume.
Key design considerations	Determine locations for trees; select or protect desired tree species; ensure at least 1,000 cubic feet of uncompacted soil volume per tree;
Key construction and maintenance considerations	Prevent soil compaction and contamination from construction related materials; plant trees following guidelines; protect existing trees with proper barriers; install irrigation per specification' mulch with hardwood chips; prune trees as needed; replace mulch as needed.

**2. Applicability and Siting Considerations**

Check the applicable County/City Comprehensive Plan or Land Development Code to determine tree planting requirements.

- **Soils:** Drainage and soil type must support selected tree species. Must have sufficient soil volume to allow a tree to grow to its mature size. In general, a large-sized tree (16 inches diameter) needs at least 1,000 cubic feet of uncompacted rootable soil.
- **Location:** Locate within an impervious surface (such as in landscape islands within parking lots or tree planters within plazas) or within 15 feet of an impervious surface (as close as practical depending on the tree species). Alternatively, within unincorporated Alachua



County, the location is consistent with the requirements for Street Trees in Section 407.43.1 (b) – Street Trees or Section 407.43.1(c) – Landscaping in Paved Ground Surface Areas of Article 4 – Landscaping of the ULDC.

- **Other structures:** Maintain appropriate distance from infrastructure and structures that could be damaged by roots and avoid overhead power lines, underground utilities, septic systems, sidewalks, curbs, patios, etc.
- **Advantages:** Interceptor trees reduce the volume of rainfall that lands on impervious surfaces and becomes stormwater. This helps reduce the total stormwater volume and the stormwater pollutant loading entering the stormwater system and can reduce the size of downstream stormwater conveyances.

### 3. Stormwater Treatment Credits

The Interceptor Tree BMP is a provisional BMP that does not have sufficient data to be accepted by FDEP or the WMDs. This BMP pollutant load reduction credit can be used to meet the additional 10% load reduction required by Alachua County for “net improvement.”

The basic stormwater treatment mechanism associated with interceptor trees is the reduction in stormwater volume associated with the interception of the rainfall by the trees. The credits set forth below are based on the research conducted by New College in Sarasota County during 2006 to document rainfall interception by oaks, pines, and palm trees (Final report, NOAA Award NA03NMF4720538) and an interpretation of the data undertaken by Steve Suau, P.E., who worked for Sarasota County during the study. Based on this study, a provisional rainfall interception value is established below:

TREE TYPES	EXISTING TREES *INTERCEPTION CREDIT
Oaks or similar species	.25
Pines or similar species	.20
Palms or similar species	.15

\* Interception credit is equal to the fraction of the annual average rainfall volume that is intercepted by the tree and prevented from becoming stormwater on a DCIA.

The volume, TN, and TP load reduction credits associated with new interceptor trees is calculated as follows:

- When new trees are used for interception credit, apply a safety factor of 2 to the calculation below.
- Determine the impervious surface area covered by the canopy of the tree(s). For new trees, estimate the area the trees will cover in 20 years.
- From the above table, select the appropriate interception credit by tree type
- Calculate the annual rainfall volume reduction

$$V = A * R * I * \text{Conversion}$$

Where:

V = average annual rainfall interception (reduction) in cubic feet (ft<sup>3</sup>)

A = Impervious area covered by tree canopy in square feet (ft<sup>2</sup>)

R = average annual rainfall in inches (in)

I = interception credit in fraction of average annual rainfall

Conversion = 1 ft/12 inches = 0.083

Area (in acres) \* Annual rainfall (in/yr) \* Interception Credit (fraction) \* Conversion factor (1 ft/12 inches) = Volume in cubic feet

- Calculate TN and TP load reductions by multiplying the volume times the EMCs listed in [Table 4.4](#).

**Load reduction LBs** = Volume (ft<sup>3</sup>) \* EMC (mg/l) \* (7.48 gal/ft<sup>3</sup>) \* (3.785 l/gal)(1 lb/453592 mg)

When using BMPTRAINS, on the watershed characteristics page, enter the interception credit fraction times the tree covered impervious area as the estimated BMP area. This will reduce the annual loading in the post development due to the addition of interceptor trees.

#### 4. Design Criteria

- Site applicability:** For residential development on private property, interceptor tree credit can only be used at sites larger than 5,000 square feet. For all sites including right-of-way with over 1,000 square feet of impervious surface to manage, no more than 10 percent of the impervious area can be mitigated using interceptor trees.
- New tree sizing:** New trees on private property must be at least 2.0 caliper inches at the time of planting, and new coniferous trees must be at least 10 feet tall to receive credit. The size of the tree should require at least a 10 to 15 gallon container.
- New tree setbacks:** New trees shall be planted within 15 feet of impervious surfaces such that their canopy covers impervious surface areas. Siting of trees shall ensure that the root system is not harmed by proximity to impervious surfaces. Trees must be spaced such that the crowns do not overlap at maturity.
- Existing tree sizing and setbacks:** Credit also applies to existing trees kept on a site if the trunk is within 15 feet of impervious surfaces and are at least 4.0-inch caliper or larger. Caliper is the diameter of the tree measured at breast height.
- Tree selection:** The trees selected shall be Florida-friendly suitable species for the site conditions and the design intent. Please consult the applicable County/City Comprehensive Plan and LDC to determine requirements. For example, within unincorporated Alachua County, the Approved Plant List is found in [Table 407.50.1](#) – Appropriate Tree Plantings in Section 407.50 of Article 4 – Landscaping of the ULDC. Alachua County/City may require a certified arborist's report to verify suitable tree selection and preservation.
- Planting sites:** Ideal planting sites within a development are those that create interception opportunities around impervious surfaces. These include areas along pathways, roads, islands and median strips, and parking lot interiors and perimeters. It is important to evaluate and record the conditions, such as soil type, soil pH, soil compaction, and the hydrology of proposed planting sites to ensure they are suitable for planting. These evaluations provide a basis for species selection and determination of the need for any special site preparation techniques.

A minimum of 1,000 cubic feet of uncompacted, rootable soil volume must be provided per tree. In planting arrangements that allow for shared rooting space amongst multiple trees, a minimum of 1,000 cubic feet of rootable soil volume must be provided for each tree. Rootable soil volume must be within 3 feet of the surface. The 1,000 cubic feet of rootable soil volume may be changed based on the specific trees and with approval by the County/City arborist.

Site characteristics determine what tree species will flourish there and whether any of the conditions, such as soils, can be improved through the addition of compost or other amendments. Table 5.2.1 presents methods for addressing common constraints to urban tree planting. Planting trees at development sites requires prudent species selection, a maintenance plan, and careful planning to avoid impacts from nearby infrastructure, runoff, vehicles or other urban elements.

**Table 5.2.1. Methods for Addressing Urban Planting Constraints**

Potential Impact	Potential Resolution
Limited Soil Volume	Provide 1,000 cubic feet of rootable soil volume per tree (this soil must be within 3 feet of the surface) unless the County/City arborist approves another volume. Use planting arrangements that allow shared rooting space. A minimum of 1,000 cubic feet of rootable soil volume must be provided for each tree in shared rooting space arrangements.
Poor Soil Quality	Test soil and perform appropriate restoration Select species tolerant of soil pH, compaction, drainage, etc. Replace very poor soils if necessary
Air Pollution	Select species tolerant of air pollutants
Damage from Lawnmowers	Use mulch to protect trees
Damage from Vandalism	Use tree cages or benches to protect trees Select species with inconspicuous bark or thorns Install lighting nearby to discourage vandalism
Damage from Vehicles	Provide adequate setbacks between vehicle parking stalls and trees
Damage from animals such as deer, rodents, rabbits, and other herbivores	Use protective fencing or chemical retardants
Exposure to pollutants in stormwater and snowmelt runoff	Select species that are tolerant of specific pollutants, such as salt and metals
Soil moisture extremes	Select species that are tolerant of inundation or drought Install underdrains if necessary Select appropriate backfill soil and mix thoroughly with site soil Improve soil drainage with amendments and tillage if needed
Increased temperature	Select drought tolerant species
Increased wind	Select drought tolerant species
Abundant populations of invasive species	Control invasive species prior to planting Continually monitor for and remove invasive species
Conflict with infrastructure	Design the site to keep trees and infrastructure separate Provide appropriate setbacks from infrastructure Select appropriate species for planting near infrastructure Use alternative materials to reduce conflict

Potential Impact	Potential Resolution
Disease or insect infestation	Select resistant species

**G. Trees along Streets and in Parking Lots.** When considering a location for planting clear lines of sight must be provided, as well as safe travel surfaces, and overhead clearance for pedestrians and vehicles. Also, ensure enough future soil volume for healthy tree growth. At least two cubic feet of useable soil per square foot of average mature tree canopy is required. Useable soil must be uncompacted, and may not be covered by impervious material. Having at least an 8-foot wide planting strip or locating sidewalks between the trees and street allows more rooting space for trees in adjacent property.

Select tree species that are drought tolerant, can grow in poor or compacted soils, and are tolerant to typical urban pollutants (oil and grease, metals, and chlorides). Additionally, select species that do not produce excessive fruits, nuts, or leaf litter, that have fall color, spring flowers or some other aesthetic benefit, and the foliage can be cut up to 6 feet from the surface to provide pedestrian and vehicle traffic underneath. Please consult the applicable County/City Comprehensive Plan and LDC to determine requirements. For example, within unincorporated Alachua County Recommended Street Trees are listed in Table 407.50.1 – Appropriate Tree Plantings in Section 407.50 of Article 4 – Landscaping of the ULDC.

**Planting Techniques.** Prepare a hole no deeper than the root ball or mass but two to three times wider than the spread of the root ball or mass. Most of the roots on a newly planted tree will develop in the top 12 inches of soil and spread out laterally. Proper handling during planting is essential to avoid prolonged transplant shock and ensure a healthy future for new trees and shrubs. Trees should always be handled by the root ball, or container, never by the trunk. Specifications for planting a tree are illustrated in Figure 5.2.1 below. Trees must be watered well after planting.

**Figure 5.2.1. Tree planting guidelines. (Adapted from Flott, 2004 and ISA, 2003b)**

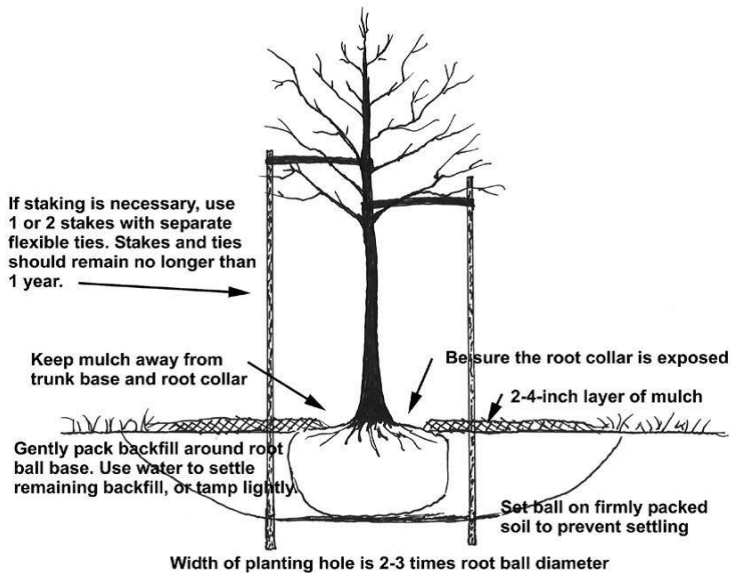

H. **Post-Planting Tree Protection.** Once the tree has been properly planted, 2 to 4 inches of organic mulch must be spread over the soil surface out to the drip line of the tree. If planting a cluster of trees, mulch the entire planting area. Slow-decomposing organic mulches, such as shredded bark, compost, leaf mulch, or wood chips provide many added benefits for trees. Mulch that contains a combination of chips, leaves, bark, and twigs is ideal for reforestation sites. Grass clippings and sawdust are not recommended as mulches because they decompose rapidly and require frequent application, resulting in reduced benefits.

For well-drained sites up to 4 inches of mulch may be applied, and for poorly drained sites a thinner layer of mulch should be applied. Mulch should never be more than 4 inches deep or applied right next to the tree trunk; however, a common sight in many landscaped areas is the —mulch volcano. This over-mulching technique can cause oxygen and moisture-level problems, and decay of the living bark at the base of the tree. A mulch-free area, 2- to 3-inches wide at the base of the tree, must be provided to avoid moist bark conditions and prevent decay (ISA, 2003a).

## 5. Construction considerations

### A. New trees

- Do not allow soil in planter areas to be compacted during construction.
- Do not allow soil in planter areas to become contaminated with construction related materials such as lime or limestone gravel, concrete, sheetrock, or paint.
- Install irrigation system to meet required specifications.
- When installing lawn around trees, install the grass no closer than 24 inches from the trunk.
- Install protective fencing if construction is ongoing, to avoid damage to new trees.
- Mulch with hardwood chips 4"-6" installed depth (2"-3" settled depth).
- Do not use pressure treated stakes. Do not stake into or through the root ball. Stakes should be set perpendicular to the prevailing wind. Stakes should be cut off 1"-2" above the highest tree tie.

### B. Existing trees

- Proposed development plans and specifications must clearly state protection procedures for trees that are to be preserved. Please consult the applicable County/City Comprehensive Plan and LDC to determine requirements.
- Within unincorporated Alachua County, existing trees must be protected during construction as required by [Section 405.12](#) of Article 2 – Trees and Native Vegetation within Chapter 406 of the ULDC. High-visibility construction fencing must be set at the outer limit of the critical root zone. The fence must prevent equipment traffic and storage under the trees. Excavation within this zone should be accomplished by hand, and roots 1/2" and larger should be preserved. It is recommended that pruning of the branches or roots be completed by, or under the supervision of, an arborist.
- Soil compaction under trees must be avoided.
- Ensure that trees that receive irrigation continue to be watered during and after construction.

## 6. Interceptor Tree Inspection Requirements

An initial inspection by a qualified professional must be done to ensure the tree has been planted, watered, and protected correctly with locations flagged if appropriate. For newly planted

trees, transplant shock is common and causes stress on a new tree. For this reason, newly planted trees must be inspected more frequently than established trees. The time it takes for a tree to become established varies with the size at planting, species, stock, and site conditions, but generally, trees should be inspected every few months during the first 3 years after planting, to identify problems and implement repairs or modify maintenance strategies.

After the first 3 years, annual inspections are sufficient to check for problems. Trees must also be inspected after major storm events for any damage that may have occurred. The inspection should take only a few minutes per tree, but prompt action on any problems encountered results in healthier, stronger trees. Inspections should include an assessment of overall tree health, an assessment of survival rate of the species planted, cause of mortality, if maintenance is required, insect or disease problems, tree protection adjustment, and weed control condition.

**7. Interceptor Tree Maintenance Requirements**

Water newly planted trees regularly (at least once a week) during the first growing season. Water trees less frequently (about once a month) during the next two growing seasons. After three growing seasons, water trees only during drought. The exact watering frequency will vary for each tree and site.

A general horticultural rule of thumb is that trees need 1 inch of rainfall per week during the growing season. Water trees deeply and slowly near the roots. Light, frequent watering of the entire plant can encourage roots to grow at the surface. Soaker hoses and drip irrigation work best for deep watering of trees. It is recommended that slow leak watering bags or tree buckets are installed to make watering easier and more effective. Continue watering until mid-fall, tapering off during lower temperatures. Pruning is usually not needed for newly planted trees but may be beneficial for tree structure and safety purposes. If necessary, prune only dead, diseased, broken or crossing branches at planting. As the tree grows, lower branches may be pruned to provide clearance above the ground, or to remove dead or damaged limbs. Trees that are removed or die should be replaced with similar species, or all water quality benefits will be lost. The property owner is responsible for all costs associated with the replacement of interceptor trees.

<b>Summary of Inspection and Maintenance for Interceptor Trees</b>	
Removal of Leaves and Debris	Fallen leaves and debris from tree foliage should be raked and removed regularly to prevent the material from being washed into the storm water. Nuisance vegetation around the tree should be removed when discovered. Dead vegetation should be pruned from the tree on a regular basis.
Pruning	It is recommended that a certified arborist or similarly qualified professional be retained to prune trees, or the property owner should learn proper pruning methods. A tree should never be topped. Topping is the practice of removing major portions of a large tree’s own crown by cutting branches to stubs or to the trunk. Tree topping shortens the life of the tree, creates weakly attached limbs prone to breakage, decay and disfigures the tree. It also eliminates the interception canopy.
Mulching	Add 4 – 6 inch deep hardwood mulch around newly planted trees and shrubs (avoid redwood and cedar, it is light and blows away and does not decompose fast enough to be beneficial to the soil health and tree’s growth).



Irrigation	A temporary irrigation system should be installed at the time of planting and maintained during the establishment period.
Pesticides and Fertilizers	Minimize the use of chemicals to only what is necessary to maintain the health of the tree. Consider using mulch around the base of the tree as a substitute to fertilizer. Do not place mulch within six inches of the trunk of the tree.
Lawn Maintenance	Keep lawn at least 24-inches from truck of tree. Competition from turf grass stunts tree growth, and even additional fertilizer and water will not overcome this effect. A bare area around the truck also helps prevent injury to the tree from a mower or string trimmer. Trunk wounds to a young tree can have a severe dwarfing effect.
Other Activities	Plant evergreen shrubs and groundcovers around the trees when possible. Care should be taken when digging near tree roots. Once tree has become established, planting of vegetation near base of tree and subsequent watering of vegetation may result in over-saturation and damage to the tree.
Removal/Replacement	See Long-term Maintenance.

**8. Submittal Requirements**

Interceptor Trees used for treatment credit as a stormwater volume and pollutant load reduction technique shall be clearly labeled on all plans, with the size and species included. The impervious surface area for which they will intercept rainfall must be shown along with its size. Approximate setbacks from property lines, structures, and underground utilities shall be shown. Street trees planted less than 10 feet from an underground utility line require the installation of a tree root guard. Temporary irrigation measures shall be shown, if applicable. A note shall be included on the permit drawings that call for County inspection after the tree has been planted, or in the case of existing canopy, after the site grading has been completed. Trees proposed for stormwater credit will need to be included in the required stormwater system O&M Plan. Alachua County/City may require a survey and certified arborist report to verify suitable tree selection or tree preservation for any trees designated for stormwater tree credit.

**SC8. Install Efficient Irrigation Systems**

In 2004, the Florida legislature created section 373.228, Florida Statutes, directing the Department of Environmental Protection, the Water Management Districts, and several stakeholder groups to devise standards for Landscape Irrigation and Florida-friendly landscape™ design. These standards were adopted in December 2006 and they are available online at:



*A soil moisture sensor, buried in the turf root zone prevents irrigation when it is not needed.*

<http://www.dep.state.fl.us/water/waterpolicy/docs/LandscapeIrrigationFloridaFriendlyDesign.pdf>.

Local governments must use these standards when adopting local ordinances after that date. In 2015, [Chapter 79, Irrigation Conservation Standards and Management Practices](#), was amended to add Article II, Landscape Irrigation Design and Maintenance Standards. When irrigation is necessary, use water conserving, low flow, programmable, and/or targeted irrigation systems. Landscaping beds with shrubs should be on separate zones from turf, and drip irrigation is recommended. If native plants are used, irrigation may be removed or turned off after they are well established, approximately one year. Many different types of irrigators are available. Consider which is most efficient for each application. To maximize irrigation efficiency of automatic in-ground irrigation systems, consider smart water application technologies such as evapotranspiration (ET) controllers or soil moisture sensors (SMS). When using soil moisture sensors, the run time for each irrigation zone can be divided into several short cycles, allowing the moisture level to be checked between cycles to optimize the amount of water delivered.

### SC9. Use Non-Potable Water Supply for Irrigation

Incorporate non-potable water as the primary source for irrigation: reclaimed water, roof runoff stored in rain barrels or cisterns, or [harvested stormwater](#). At the lot level, consider [rainwater harvesting](#) with cisterns or rain barrels for subsequent use to irrigate landscapes. While the relatively small volume stored in rain barrels will not measurably reduce stormwater from the site, they may be sufficient for irrigating small garden areas and may increase occupant's awareness of water use and promote conservation.



### SC10. Community and Homeowner Education

All community developments should include a community or homeowner education program. This is especially true for developments that incorporate LID BMPs into their stormwater treatment train. The town of [Harmony](#) provides one example education program. Seven different signs are placed in public areas to inform residents about natural resources, with panels that can be easily changed as desired to teach about different issues. A website for residents gives wide ranging information, including water and energy efficiency, native landscaping, conservation of resources, waste reduction and local wildlife identification. Also, information brochures are given to prospective and new homeowners to introduce them to the community, its resources and efforts to protect natural resources.

## 5.3. Structural Stormwater BMPs

The next section of the Alachua County Stormwater Management Manual provides detailed information on structural stormwater BMPs. This includes:

- [Section 5.3.](#) Retention basin
- [Section 5.4.](#) Exfiltration trench
- [Section 5.5.](#) Underground storage and retention
- [Section 5.6.](#) Rain gardens
- [Section 5.7.](#) Treatment swales
- [Section 5.8.](#) Vegetated natural buffers
- [Section 5.9.](#) Pervious pavements

[Section 5.10.](#) Green roofs with cisterns

[Section 5.11.](#) Rainwater harvesting systems

[Section 5.12.](#) Wet detention systems

[Section 5.13.](#) Stormwater harvesting

[Section 5.14.](#) Up-flow filter systems

[Section 5.15.](#) Managed aquatic plant systems

[Section 5.16.](#) Biofiltration systems

For retention BMPs, remember that Table B1-1 and Table B2-1 are in [Appendix B](#).

Use [Table B1-1](#) to determine the treatment volume needed to achieve an 80% pollutant load reduction if retention systems are being used to fully achieve the required level of pollutant load reduction.

If retention basins are being used as part of a BMP treatment train to achieve some level of pollutant load reduction but not the total amount of the required nutrient load reduction, use [Table B2-1](#).

### 5.3. Retention Basin Design Criteria

#### 5.3.1. Description

A “retention basin” is a recessed area within the landscape designed to store and retain a defined quantity of runoff allowing it to percolate through permeable soils into the shallow ground water aquifer. This section discusses the requirements for retention systems, historically referred to as “dry retention basins,” which are constructed or natural depression areas, often integrated into a site’s landscaping, where the bottom is typically flat, and turf, natural groundcovers or other appropriate vegetative or other methods are used to promote infiltration and stabilize the basin bottom and slopes (see Figure 5.3.1).

Small retention basins that serve small drainage areas and that are integrated into the landscape plan, such as along the edge of property and parking lot islands, are called “Rain Gardens.” These are a special type of retention basin and they are further discussed in [Section 5.6](#).

Soil permeability and water table conditions are essential to successful use of retention basins since they must percolate the required treatment runoff volume within a specified time following a storm event. After drawdown has been completed, the basin does not hold any water, thus the system is normally “dry.” Unlike detention basins, the treatment volume for retention systems is not discharged to surface waters.

Retention basins provide numerous benefits, including reducing stormwater volume, which reduces the average annual pollutant loading that may be discharged from the system. Additionally, many stormwater pollutants such as suspended solids, oxygen demanding materials, heavy metals, bacteria, some varieties of pesticides, and nutrients are removed as runoff percolates through the soil profile.

#### RETENTION BASIN SUMMARY

Advantages/Benefits	Reduces stormwater volume, peak discharge rate, pollutant loadings, and heat island effect. Provides ground water recharge and enhanced site aesthetics.
Disadvantages/Limitations	Can require large footprint. Do not construct within 75 feet of a public or private potable water supply well or within 15 feet of an on-site wastewater disposal and treatment system. Site must have appropriate soil and SHGWT conditions for infiltration. Not appropriate on sites with potential hazardous or toxic materials.
Volume Reduction Potential	High
Pollutant Removal Potential	High for all pollutants

Key design considerations	<a href="#">SHGWT</a> at least 2 feet below bottom; recovery of treatment volume within 24 – 72 hours; sides and bottoms must be stabilized with vegetation or other approved materials
Key construction and maintenance considerations	Minimize soil compaction and sedimentation during construction; ensure design infiltration is met after construction; inspect during wet season to see if water is ponding and not infiltrating properly; restore infiltration capacity as needed to meet permit requirements

To accomplish the desired level of pollutant load reduction, retention basins shall be designed in accordance with the following design and performance criteria.

**Figure 5.3.1. Typical Cross-section of “Dry” Retention Basin**

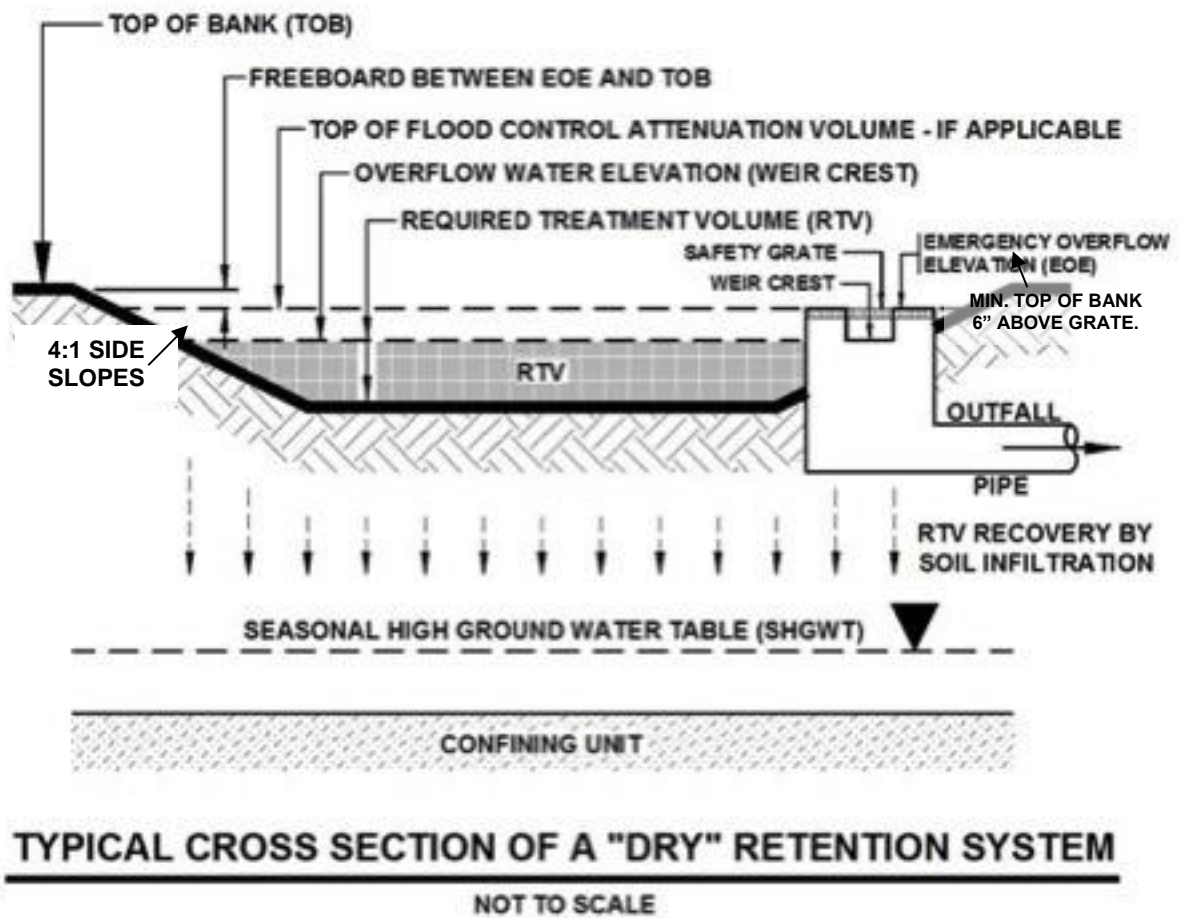

**5.3.2. Required Treatment Level and Associated Treatment Volume**

The Required Treatment Volume (RTV) necessary to achieve the desired treatment efficiency shall be routed to the retention basin and percolated into the ground. The required nutrient load reduction will be determined by type of water body to which the stormwater system discharges and the associated performance standard as set forth in [Section 5.3](#) of this Manual.



Treatment volumes to achieve the required load reduction efficiencies shall be determined based on the percentage of DCIA and the weighted Curve Number for non-DCIA areas as set forth in Tables B1-1 and B2-1.

### 5.3.3. Calculating Load Reduction Efficiency for a Given Retention Volume

Use [Table B1-1](#) to determine the treatment volume needed to achieve an 80% pollutant load reduction if retention systems are being used to fully achieve the required level of pollutant load reduction.

If retention basins are being used as part of a BMP treatment train to achieve some level of pollutant load reduction but not the total amount of the required nutrient load reduction, use [Table B2-1](#).

### 5.3.4. Design Criteria

1. The retention basin must have the capacity to retain the required treatment volume without a discharge and without considering soil storage.
2. The retention basin must recover the required treatment volume of stormwater within 72 hours assuming average Antecedent Runoff Condition (ARC 2). Systems that are landscaped need to use appropriate plants that can either tolerate inundation for 72 hours or the system needs to recover the required treatment volume within 24 to 36 hours to prevent damage to vegetation. A recovery analysis is required that accounts for the mounding of ground water beneath the retention basin. Requirements related to safety factors, mounding analysis and supporting soil testing is provided in Appendix C of this Manual.
3. The seasonal high ground water table shall be at least two feet beneath the bottom of the retention basin unless the applicant demonstrates, based on plans, test results, calculations or other information, that an alternative design is appropriate for the specific site conditions.
4. The retention basin sides and bottom shall be stabilized with permanent vegetative cover, some other pervious material, or other methods acceptable to the County that will prevent erosion and sedimentation. Vegetation shall not be muck grown sod.
5. Retention basins shall not be constructed within 75 feet of a public or private potable water supply well or within 15 feet of an on-site wastewater disposal and treatment system.
6. The top bank of a retention basin shall not be within 5-ft of the right-of-way.

### 5.3.5. Required Site Information

Successful design of a retention system depends greatly upon knowing conditions at the site, especially information about the soil, geology, and water table conditions. Specific data and analyses required for the design of a retention system including details related to safety factors, mounding analyses, and required soil testing are set forth in [Appendix C](#) of this Manual.

### 5.3.6. Retention Basin Construction

Retention basin construction procedures and the overall sequence of site construction are two key factors that can control the effectiveness of retention basins. The applicant must demonstrate that the design infiltration rate will be met after construction by minimizing soil compaction during construction and minimizing the amount of sediment deposited into the retention basin.

Because [stormwater management systems](#) are required to be constructed during the initial phases of site development, retention basins are often exposed to poor quality surface runoff. Stormwater runoff during construction contains considerable amounts of suspended solids,

organics, clays, silts, trash and other undesirable materials. For example, the subgrade stabilization material used during construction of roadways and pavement areas typically consists of clayey sand or soil cement. If a storm occurs when these materials are exposed (prior to placement of the roadway wearing surface), considerable amounts of these materials end up in the stormwater conveyance system and the retention basin, hindering infiltration through the system. Another source of fine material generated during construction is disturbed surface soil that can release large quantities of organics and other fine particles. Fine particles of clay, silt, and organics at the bottom of a retention basin also create a poor infiltrating surface.

The following construction procedures are required to avoid degradation of retention basin infiltration capacity due to construction practices:

- The location and dimensions of the retention basin shall be verified on-site prior to its construction. All design requirements including retention basin dimensions and distances to foundations, septic systems, wells, etc., need to be verified.
- The location of retention basins shall be clearly marked at the site to prevent unnecessary vehicular traffic across the area causing soil compaction.
- Initially construct the retention basin by excavating the basin bottom and sides to approximately 12 inches above final design grades.
- Excavation shall be done by lightweight equipment to minimize soil compaction. Tracked, cleated equipment does less soil compaction than equipment with tires.
- After the drainage area contributing to the basin has been fully stabilized, the interior side slopes and basin bottom shall be excavated to final design specifications. The excess soil and undesirable material must be carefully excavated and removed from the basin so that all accumulated silts, clays, organics, and other fine sediment material have been removed from the pond area. The excavated material shall be disposed of in a manner that assures it will not re-enter the retention basin.
- Once the basin has been excavated to final grade, the entire basin bottom must be deep raked and loosened for optimal infiltration. The depth to be raked is dependent on the type, weight and contact pressure of the construction equipment used during the bulk excavation of the basin.

An applicant may propose alternative construction procedures to assure that the design infiltration rate of the constructed and stabilized retention basin is met.

### **5.3.7. Inspections, Operation and Maintenance**

Maintenance issues associated with retention basins are related to clogging of the porous soils, which reduces or prevents infiltration thereby slowing recovery of the stormwater treatment volume and often resulting in standing water. Sedimentation can cause clogging, resulting in the sealing of the bottom or side slope soils. It can also occur from excessive loading of oils and greases or from excessive algal or microorganism growth. Standing water within a retention basin can also result from an elevated high water table or from ground water mounding, both of which can present long term operational issues that may require redesign of the system.

To determine if an infiltration system is properly functioning or whether it needs maintenance requires that an inspection be done within 72 hours after a storm. The inspection should determine if the retention basin is recovering its storage volume within its permitted time frames, generally 24 to 72 hours after a storm. If this is not occurring and there is standing water, then

the cause must be determined and actions undertaken beginning with those specified in the system's Operation and Maintenance Plan.

1. Inspection Items:

- Inspect basin for storage volume recovery within the permitted time set forth in [Section 5.3.4](#). Failure to percolate the required treatment volumes indicates reduction of the infiltration rate and a need to restore system permeability.
- Inspect and monitor sediment accumulation on the basin bottom or inflow to prevent clogging of the retention basin or the inflow pipes.
- Inspect vegetation of bottom and side slopes to assure it is healthy, maintaining coverage, and that no erosion is occurring within the retention basin.
- Inspect inflow and outflow structures, trash racks, and other system components for accumulation of debris and trash that would cause clogging and adversely impact operation of the retention basin.
- Inspect the retention basin for potential mosquito breeding areas such as where standing water occurs after 72 hours or where cattails, other invasive or nuisance vegetation becomes established.

2. Maintenance Activities As-Needed To Prolong Service:

- If needed, restore the infiltration capacity of the retention basin so that it meets the permitted recovery time for the required treatment volume.
- Remove accumulated sediment from retention basin bottom and inflow and outflow pipes and dispose of properly. Please note that stormwater sediment disposal may be regulated under [Chapter 62-701, F.A.C.](#) (Sediment removal should be done when the system is dry and when the sediments are cracking.)
- Remove trash and debris inflow and outflow structures, trash racks, and other system components to prevent clogging or impeding flow.
- Maintain healthy vegetative cover to prevent erosion in the basin bottom, side slopes or around inflow and outflow structures. Vegetation roots also help to maintain soil permeability. Grass needs to be mowed and grass clippings removed from the basin to reduce internal nutrient loadings.
- Eliminate mosquito-breeding habitats.
- Assure that the contributing drainage area is stabilized and not a source of sediments.

## 5.4. Exfiltration Trench Design Criteria

### 5.4.1. Description

An exfiltration trench is a subsurface retention system consisting of a conduit such as perforated pipe surrounded by natural or artificial aggregate which temporarily stores and infiltrates stormwater runoff (Figure 5.4.1). Stormwater passes through the perforated pipe and infiltrates through the trench sides and bottom into the shallow ground water aquifer. The perforated pipe increases the storage available in the trench and helps promote infiltration by making delivery of the runoff more effective and evenly distributed over the length of the system.

Soil permeability and water table conditions must be such that the trench system can percolate the required stormwater runoff treatment volume within a specified time following a storm event. The trench system is returned to a normally “dry” condition when drawdown of the treatment volume is completed. Like retention basins, the treatment volume in exfiltration trench systems is not discharged to surface waters.

Like other types of retention systems, exfiltration trenches provide reduction of stormwater volume that reduces pollutant loads. Additionally, substantial amounts of suspended solids, oxygen demanding materials, heavy metals, bacteria, some varieties of pesticides and nutrients such as phosphorus may be removed as runoff percolates through the soil profile.

The operational life of an exfiltration trench depends on site conditions, system design, and maintenance. Sediment accumulation and clogging by fines can reduce the life of an exfiltration trench. Total replacement of the trench may be the only possible means of restoring the treatment capacity and recovery of the system. Periodic replacement of the trench should be considered routine operational maintenance when selecting this management practice. As such, exfiltration trenches must be located where replacement can readily occur. They shall not be placed within 10 feet of a building and must be designed with adequate accessibility for maintenance or trench replacement.

### EXFILTRATION TRENCH SUMMARY

Advantages/Benefits	Reduces stormwater volume, peak discharge rate, pollutant loadings, and heat island effect. Provides ground water recharge and enhanced site development potential.
Disadvantages/Limitations	Only permitted for projects to be operated by entities with single owners or with full-time maintenance staff. Do not construct within 75 feet of a public or private potable water supply well or within 15 feet of an on-site wastewater disposal and treatment system Site must have appropriate soil and SHGWT conditions for infiltration. Not appropriate on sites with potential hazardous or toxic materials.
Volume Reduction Potential	High

Pollutant Removal Potential	High for all pollutants
Key design considerations	<a href="#">SHGWT</a> at least 2 feet below bottom; recovery of treatment volume within 24 – 72 hours; pretreatment via swales or catch basins essential to prevent litter, trash, leaves, and other debris from entering exfiltration trench.
Key construction and maintenance considerations	Minimize soil compaction and sedimentation during construction; block Inflows to the trench until the contributing drainage area is stabilized. ensure design infiltration is met after construction; inspect during wet season to see if water is ponding and not infiltrating properly; restore infiltration capacity as needed to meet permit requirements

**5.4.2. Required Level of Treatment and Associated Treatment Volume**

The Required Treatment Volume (RTV) necessary to achieve the desired treatment efficiency shall be routed to the exfiltration trench and percolated into the ground. The required nutrient load reduction will be determined by type of water body to which the stormwater system discharges and the associated performance standard as set forth in [Section 4.3](#) of this Manual.

Treatment volumes to achieve the required load reduction efficiencies shall be determined based on the percentage of DCIA and the weighted Curve Number for non-DCIA areas as set forth in Table B1-1 and Table B2-1.

Exfiltration trenches must be designed to have the capacity to retain the required treatment volume without discharging to surface waters.

**5.4.3. Calculating Load Reduction Efficiency for a Given Retention Volume**

Use [Table B1-1](#) to determine the treatment volume needed to achieve an 80% pollutant load reduction if exfiltration systems are being used to fully achieve the required level of pollutant load reduction.

If exfiltration systems are being used as part of a BMP treatment train to achieve some level of pollutant load reduction but not the total amount of the required nutrient load reduction, use [Table B2-1](#).



Figure 5.4.1. Cross-section of a “Dry” Exfiltration Trench (N.T.S.)

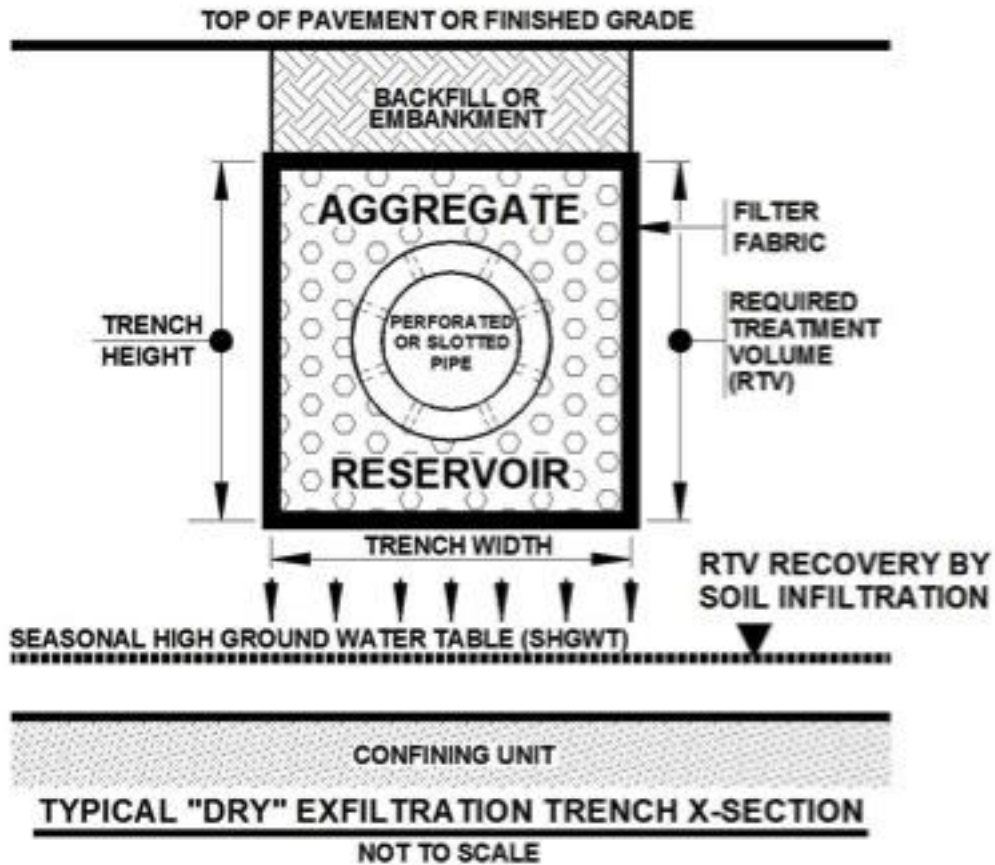

**5.4.4. Design and Performance Criteria**

Exfiltration trenches must have the capacity to retain the required treatment volume without a discharge and without considering soil storage. The required treatment volume initially shall be retained in the perforated/slotted pipe and the surrounding aggregate reservoir.

1. Exfiltration trenches shall only be permitted for projects to be operated by entities with single owners or entities with full-time maintenance staffs.
2. The exfiltration trench must provide the capacity for the required treatment volume of stormwater within 72 hours, with a safety factor of two, following a storm event assuming average antecedent runoff condition (ARC 2). In exfiltration systems, the stormwater is drawn down by natural soil infiltration and dissipation into the ground water table as opposed to underdrain systems that rely on artificial methods such as drainage pipes. A recovery analysis is required that accounts for the mounding of ground water beneath the exfiltration system. Details related to safety factors, mounding analysis and supporting soil testing is provided in [Appendix C](#) of this Manual
3. Minimum perforated or slotted pipe diameter shall be twelve (12) inches. Pipe shall not exceed 45° bends.
4. Minimum aggregate reservoir trench width shall be three (3) feet.
5. To assure recovery of the Required Treatment Volume (RTV), a dry exfiltration trench must be designed so that the invert elevation of the trench must be at least two feet above the seasonal high ground water table elevation unless the applicant demonstrates, based on

plans, test results, calculations or other information, that an alternative design is appropriate for the specific site conditions. Refer to Figure 6.4.1 for additional information.

6. To prevent surrounding soil migration into the aggregate reservoir, the reservoir must be enclosed on all sides by a permeable woven or non-woven filter fabric. The permeability of the filter fabric must be greater than the permeability of the surrounding soil.
7. To facilitate inspection of proper operation and maintenance of the exfiltration system, the system must be designed with sufficient access for inspection. Appropriate inspection access is dependent on the design of the specific system, but all must provide the ability to determine whether the system is maintaining the design infiltration rate and storage volume. Examples of acceptable inspection methods include designing the system such that the terminal ends of any perforated/slotted pipe or storage areas either:
  - Terminating in an accessible drainage inlet or manhole; or
  - Having an eight (8) inch minimum diameter inspection port installed at any terminal "dead end" of any perforated/slotted pipe or storage areas. Sweep in end no greater than 45° bend and 300'.
  - Having an observation well that allows checking of the recovery of the RTV.
  - Refer to Figure 6.4.2 for additional information and recommendations.

To provide a collection space for trash and other inflow debris, a minimum 24-inch deep maintenance sump will be required for all system inlets and manholes. A minimum twelve-inch (12") diameter weep hole shall be placed in the bottom of the maintenance sump to facilitate the infiltration of stormwater into the underlying soils after a rainfall event. Refer to Figure 6.4.2 for additional information and recommendations.

To reduce the potential for trash, debris and oil/grease inflow into the exfiltration trench system; a baffle, trash tee or other equivalent device must be installed at the end of the perforated/slotted pipe(s) in all access inlets and manholes. Refer to Figures 6.4.3 and 6.4.4 for additional information and recommendations.

8. Sustainable void spaces must be used in computing the storage volume in the aggregate reservoir. These aggregate void space values *shall be the greater* of the following:
  - 35% of aggregate volume; or
  - 80% of the measured testing lab values for the selected aggregate(s), if obtained and certified by a Florida licensed geotechnical professional.

The material used in the aggregate reservoir shall be washed to assure that no more than five percent (5%) of the materials passing a #200 sieve.

9. Exfiltration trenches shall not be constructed within 75 feet of a public or private potable water supply well or within 15 feet of an on-site wastewater disposal and treatment system.

#### **5.4.5. Required Site Information**

Design of an exfiltration system must consider site conditions including soil, geology, and water table conditions. Specific data and analyses required for the design of retention BMPs, including an exfiltration trench are set in [Appendix C](#) of this Manual.

Figure 5.4.2. Typical Exfiltration Trench Sumps and Dead End Details

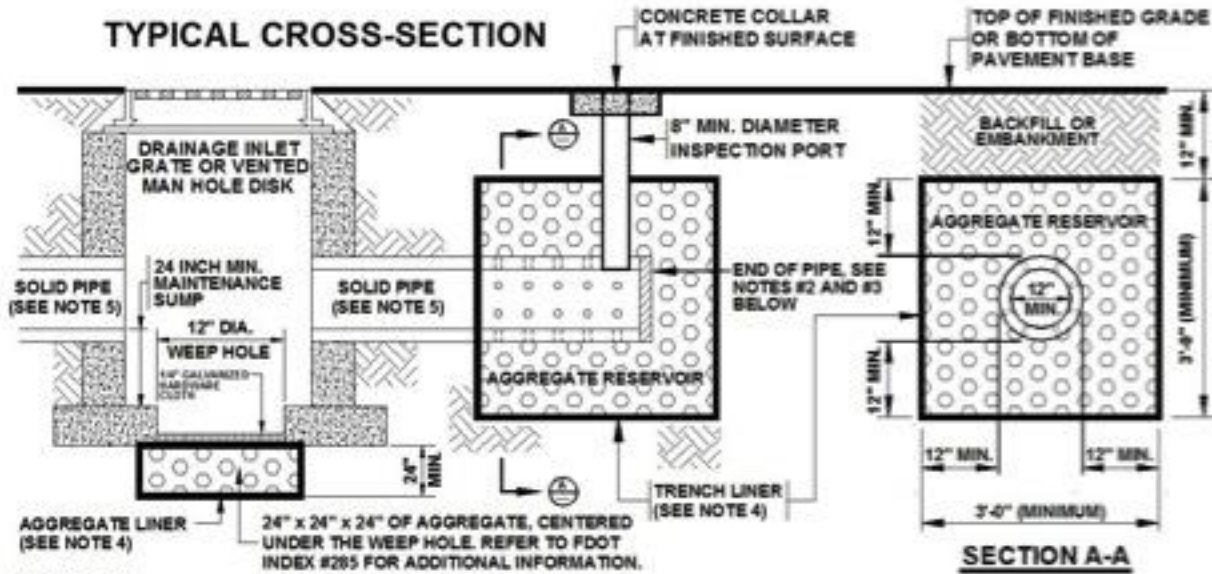

**NOTES:**

1. SEE THE SEPARATE DETAIL SKETCHES FOR SEDIMENT / TRASH BAFFLES & TEES, OR OTHER EQUIVALENT DEVICES.
2. PERFORATED OR SLOTTED PIPES SHALL TERMINATE A MINIMUM OF TWO (2) FEET FROM THE END OF THE EXFILTRATION TRENCH, OR CONNECT TO ADDITIONAL INLETS OR MANHOLES.
3. PIPE "DEAD ENDS" (IF UTILIZED) SHALL TERMINATE INTO A SOLID PLUG OR END CAP.
4. SIDES, TOP, BOTTOM, AND ENDS OF TRENCH (AND AGGREGATE BELOW DRAIN HOLE) SHALL BE LINED WITH A PERVIOUS WOVEN OR NON-WOVEN ENGINEERING FILTER FABRIC. OVERLAP FABRIC LINING MATERIAL A MINIMUM OF TWELVE (12) INCHES AT THE TOP OF THE AGGREGATE.
5. REFER TO FDOT INDEX #285 FOR ADDITIONAL INFORMATION ON THE MINIMUM LENGTHS OF SOLID PIPE EXITING THE ACCESS MANHOLE OR DRAINAGE INLET, AND THE MINIMUM CROSS SECTIONAL DIMENSIONS OF THE AGGREGATE RESERVOIR.

**"GENERIC" EXFILTRATION TRENCH SUMPS & DEAD END DETAILS**

NOT TO SCALE

Figure 5.4.3. Detail for Exfiltration Trench Trash Baffle

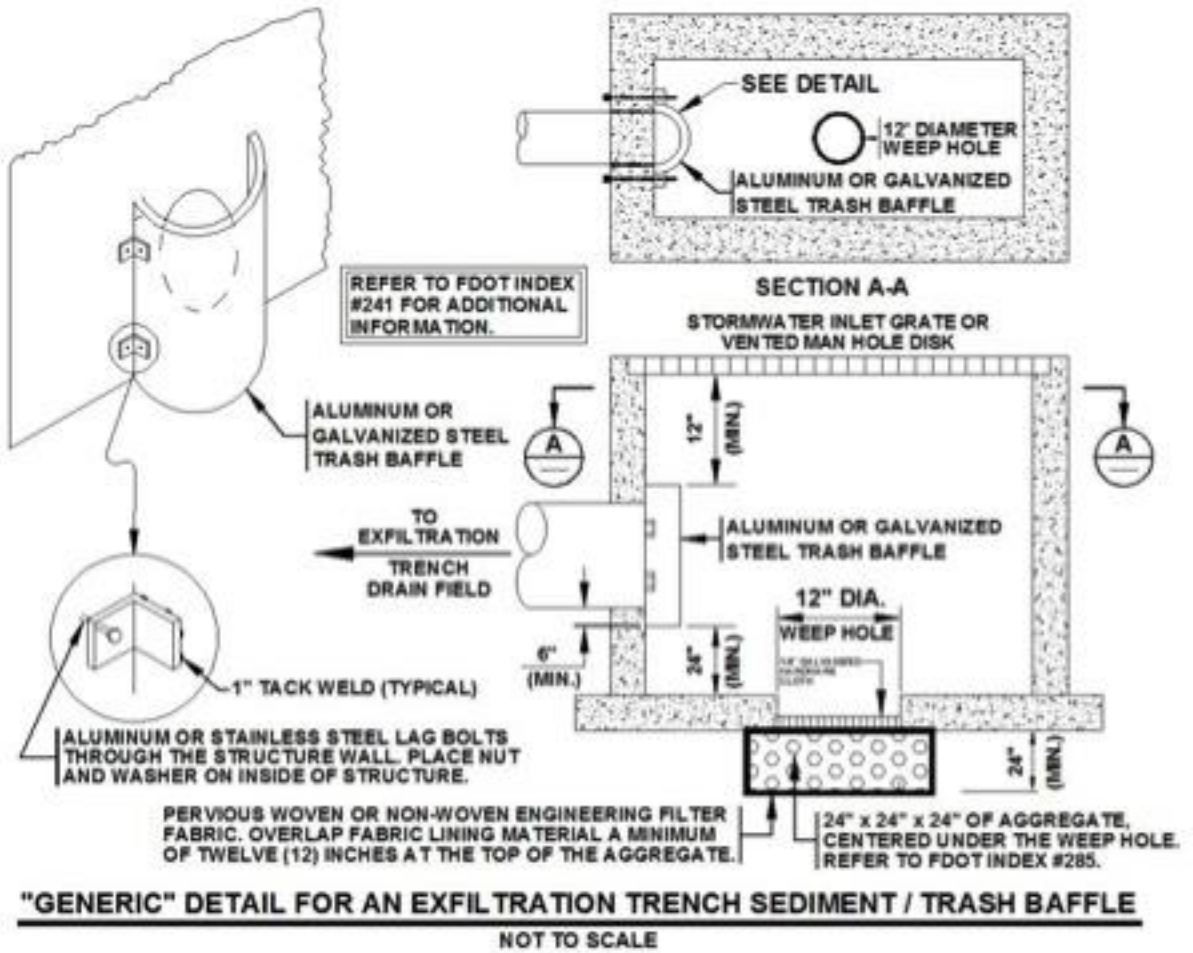
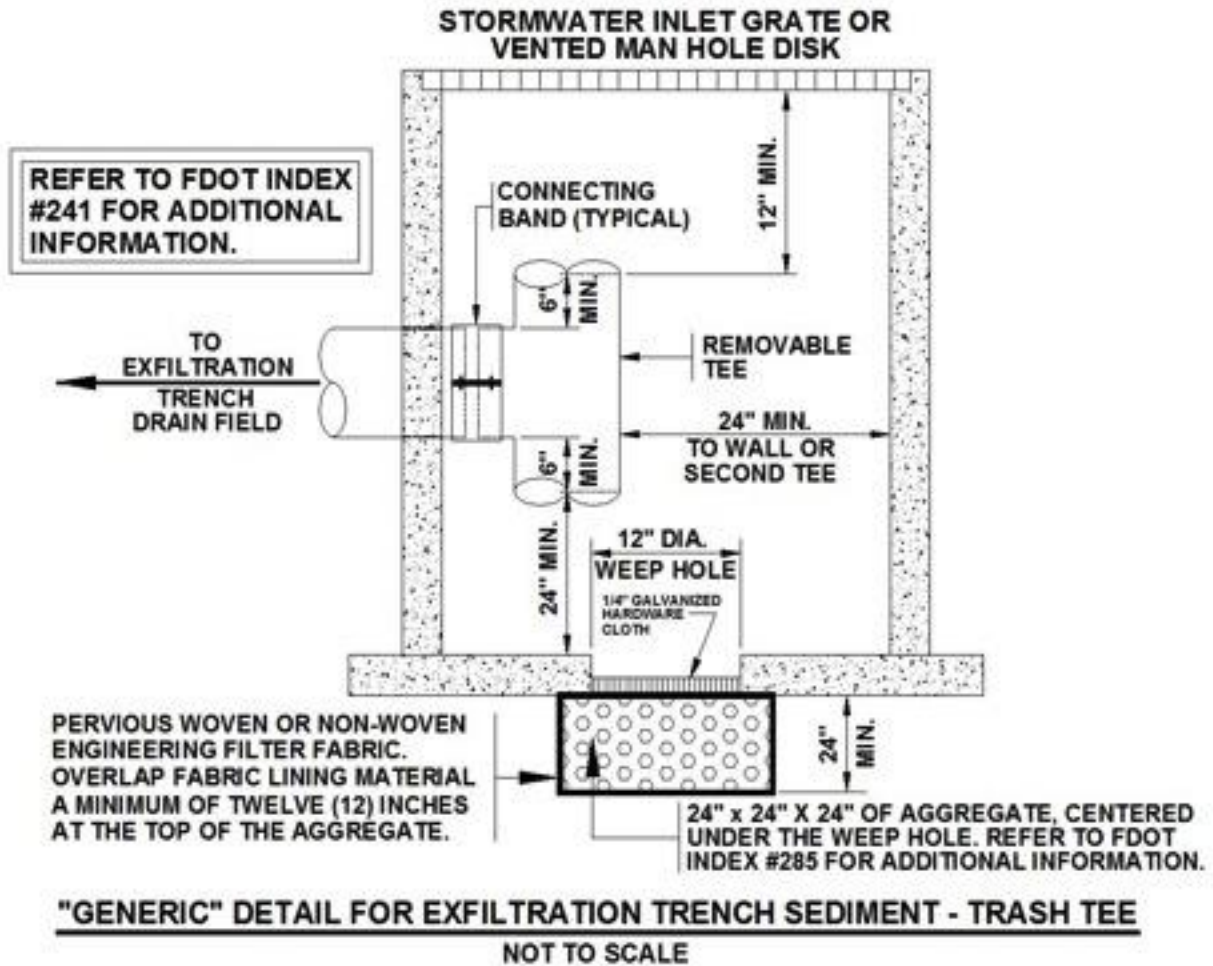



Figure 5.4.4. Generic Detail for a Typical Exfiltration Trench Trash Tee



**5.4.6. Construction requirements**

During construction, every effort should be made to limit the parent soil and debris from entering the trench. Any method used to reduce the amount of fine sediment entering the exfiltration trench during construction will extend the life of the system.

The location and dimensions of the exfiltration trench shall be verified on-site prior to trench construction. All design requirements including trench dimensions and distances to foundations, septic systems, wells, etc., need to be verified.

To minimize sealing of the soil surface, the trench shall be excavated with a backhoe rather than front-end loaders or bulldozers whose blades will seal the infiltration soil surface.

1. Excavated materials shall be placed a sufficient distance from the sides of the excavated area to minimize the risk of sidewall cave-ins and prevent the material from re-entering the trench.
2. The trench bottom and side walls shall be inspected for materials that could puncture or tear the filter fabric, such as tree roots, and assure they are not present.
3. The aggregate material shall be inspected prior to placement to ensure it meets size specifications and is washed to minimize fines and debris.



4. Inflows to the trench shall be temporarily blocked until the contributing drainage area is stabilized to prevent sediment from entering and clogging the trench.
5. An applicant may propose alternative construction procedures to assure that the permitted infiltration rate of the constructed exfiltration trench is met provided they are acceptable and approved by the County.

#### **5.4.7. Inspections, Operation and Maintenance**

##### 1. Inspection Items:

- Monitor facility for sediment accumulation in the pipe (when used) and storage volume recovery (i.e., drawdown capacity). Observation wells and inspection ports should be checked following 3 days minimum dry weather. Failure to percolate stored runoff to the design treatment volume level within 72 hours indicates binding of soil in the trench walls and/or clogging of geotextile wrap with fine solids. Reductions in storage volume due to sediment in the distribution pipe, also reduces efficiency. Minor maintenance measures can restore infiltration rates to acceptable levels short term. Major maintenance (total rehabilitation) is required to remove accumulated sediment in most cases or to restore recovery rate when minor measures are no longer effective or cannot be performed due to design configuration.
- Inspect appurtenances such as sedimentation and oil and grit separation traps or catch basins as well as diversion devices and overflow weirs when used. Diversion facilities and overflow weirs should be free of debris and ready for service. Sedimentation and oil/grit separators should be scheduled for cleaning when sediment depth approaches cleanout level. Cleanout levels should be established not less than 1 foot below the invert elevation of the chamber.

##### 2. As-Needed To Prolong Service:

- Remove sediment from sediment or oil/grease traps, catch basin inlets, manholes, and other appurtenant structures and dispose of properly.
- Remove debris from the outfall or "Smart Box" (diversion device in the case of off-line facilities).
- Removal of sediment and cleaning of trench system. This process normally involves facilities with large pipes. Cleanout may be performed by suction hose and tank truck and/or by high-pressure jet washing.

##### 3. As Needed To Maintain 72-Hour Exfiltration Rate:

- Periodic clean-out or rehabilitation of the system to remove any accumulated trash, sediment and other inflow debris and remediate any clogging of perforated pipes.
- Total replacement of the system. In some cases, the system may not be able to be rehabilitated sufficiently to restore the design storage and infiltration rate. In these cases, complete replacement of the system may be necessary. The applicant shall provide an estimate of the expected life expectancy of the exfiltration trench and an estimate of the cost to replace the trench.

## 5.5. Underground Storage and Retention Systems Design Criteria

### 5.5.1. Description

Underground storage and retention systems are special types of retention systems that capture the Required Treatment Volume (RTV) in an underground storage system and “drainfield.” Examples include underground tanks or chambers with several commercially-available models. Generally, these systems consist of lightweight, high strength modular units with “open” bottoms to allow for soil infiltration (refer to Figure 5.5.1 below). These systems are sometimes used where land values are high, and the owner/applicant desires to minimize the potential loss of usable land with other types of retention BMPs. Underground retention systems are not intended to have human access for maintenance.

#### UNDERGROUND STORAGE AND RETENTION SUMMARY

Advantages/Benefits	Reduces stormwater volume, peak discharge rate, pollutant loadings, and heat island effect. Provides ground water recharge and enhanced site development potential.
Disadvantages/Limitations	Only permitted for projects to be operated by entities with single owners or with full-time maintenance staff. Do not construct within 75 feet of a public or private potable water supply well or within 15 feet of an on-site wastewater disposal and treatment system Site must have appropriate soil and SHGWT conditions for infiltration. Not appropriate on sites with potential hazardous or toxic materials.
Volume Reduction Potential	High
Pollutant Removal Potential	High for all pollutants
Key design considerations	<a href="#">SHGWT</a> at least 2 feet below bottom; recovery of treatment volume within 24 – 72 hours; pretreatment via swales or catch basins essential to prevent litter, trash, leaves, and other debris from entering exfiltration trench; a baffle, trash tee or other equivalent device must be installed at the end of the perforated/slotted pipe(s) in all access inlets and manholes
Key construction and maintenance considerations	Minimize soil compaction and sedimentation during construction; block Inflows to the system until the contributing drainage area is stabilized. Ensure design infiltration is met after construction; inspect during wet season to see if water is ponding and not infiltrating properly; restore infiltration capacity as needed to meet permit requirements

Figure 5.5.1. Generic Underground Retention System

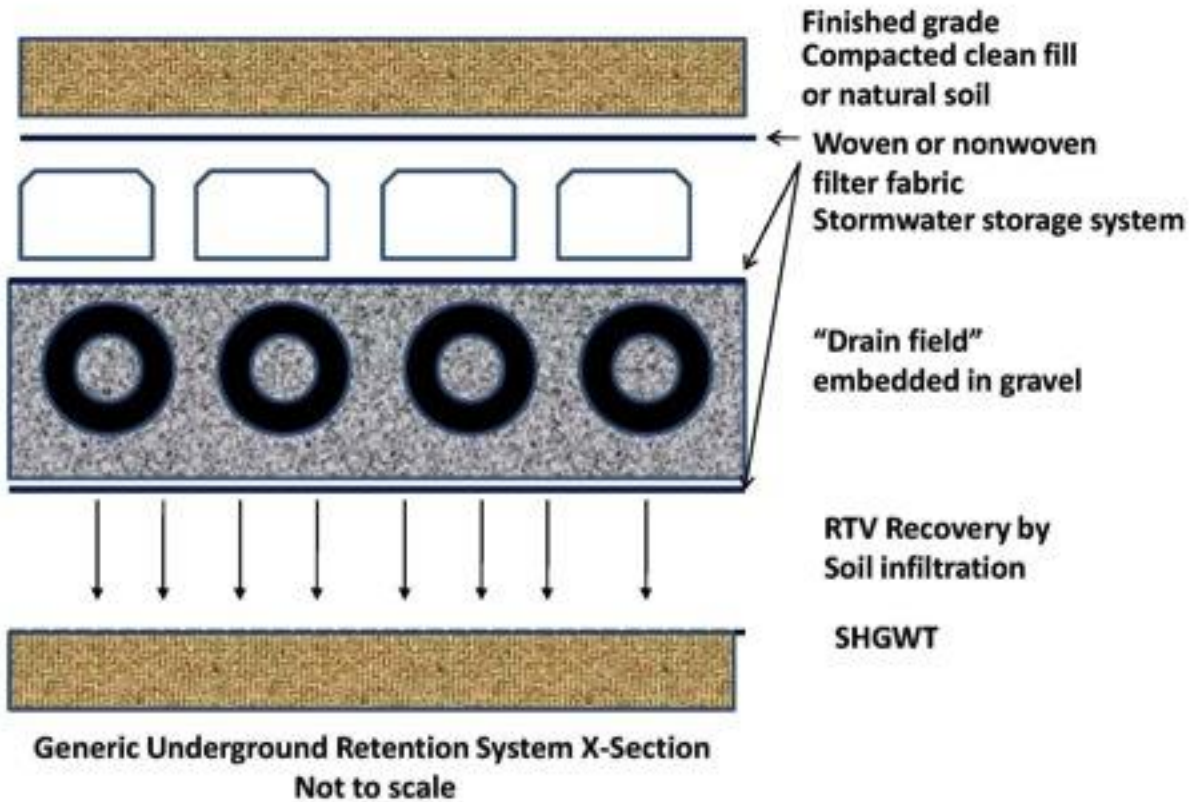

**5.5.2. Required Treatment Volume**

The Required Treatment Volume (RTV) necessary to achieve the desired treatment efficiency shall be routed to the underground storage and retention system and percolated into the ground. The required nutrient load reduction will be determined by type of waterbody to which the stormwater system discharges and the associated performance standard as set forth in [Section 5.3](#) of this Manual.

Treatment volumes to achieve the required load reduction efficiencies shall be determined based on the percentage of DCIA and the weighted Curve Number for non-DCIA areas as set forth in Table B1-1 and Table B2-1.

Underground storage and retention systems must be designed to have the capacity to retain the required treatment volume without considering discharges to ground or surface waters.

**5.5.3. Calculating Load Reduction Efficiency for a Given Retention Volume**

Use [Table B1-1](#) to determine the treatment volume needed to achieve an 80% pollutant load reduction if underground retention systems are being used to fully achieve the required level of pollutant load reduction.

If underground retention basins are being used as part of a BMP treatment train to achieve some level of pollutant load reduction but not the total amount of the required nutrient load reduction, use [Table B2-1](#).

#### 5.5.4. Design Criteria

The underground storage and retention system must have the capacity to retain the required treatment volume without a discharge and without considering soil storage.

The underground storage and retention system must recover the required treatment volume of stormwater within 72 hours, with a safety factor of two, assuming average Antecedent Runoff Condition (ARC 2). A recovery analysis is required that accounts for the mounding of ground water beneath the retention basin. Details related to safety factors, mounding analysis and supporting soil testing is provided in [Appendix C](#) of this Manual.

1. The seasonal high ground water table shall be at least two feet beneath the bottom of the underground storage and retention system.
2. Sustainable void spaces must be used in computing the storage volume in the aggregate reservoir. These aggregate void space values *shall be the greater* of the following:
  - 35% of aggregate volume; or
  - 80% of the measured testing lab values for the selected aggregate(s), if obtained and certified by a Florida licensed geotechnical professional.
3. Minimum perforated or slotted pipe diameter of twelve (12) inches.
4. Minimum aggregate reservoir trench width of three (3) feet.
5. To minimize the loss of the Required Treatment Volume (RTV), the underground retention system must be designed so that the invert elevation of the trench must be at least two feet above the seasonal high ground water table elevation unless the applicant demonstrates, based on plans, test results, calculations or other information, that an alternative design is appropriate for the specific site conditions.
6. To facilitate inspection/maintenance of the underground retention system, the terminal ends of the perforated/slotted pipe must either:
  - Terminate in an accessible drainage inlet or manhole;
  - Have an eight (8") inch minimum diameter inspection port installed at any terminal "dead end" of the perforated/slotted pipe; or
  - Have an observation well that allows checking of the recovery of the RTV.

Refer to [Figure 5.4.2](#) for additional information and recommendations. Alternatively, the applicant may propose a system that is manufactured with an equivalent functional component that would provide for inspection and maintenance.

7. To provide a collection space for trash and other inflow debris, a minimum 24-inch deep maintenance sump will be required for all system inlets and manholes. A minimum twelve inch (12") diameter weep hole shall be placed in the bottom of the maintenance sump to facilitate the infiltration of stormwater into the underlying soils after a rainfall event. Refer to [Figure 5.4.3](#) for additional information and recommendations. Alternatively, the applicant may propose a system that is manufactured with an equivalent functional component that would capture trash and other inflow debris and keep it out of the retention system.
8. To reduce the potential for trash, debris and oil/grease inflow into the underground retention system; a baffle, trash tee or other equivalent device must be installed at the end of the perforated/slotted pipe(s) in all access inlets and manholes. Refer to [Figures 5.4.3](#) and [5.4.4](#) for additional information and recommendations. Alternatively, the applicant may propose a system that is manufactured with an equivalent functional component that would capture trash, debris, and oil/grease inflow into the underground retention system
9. The Required Treatment Volume (RTV) shall be initially retained in the perforated/slotted pipe and the surrounding aggregate reservoir.

10. Underground storage and retention systems shall not be constructed within 75 feet of a public or private potable water supply well or within 15 feet of an on-site wastewater disposal and treatment system.

#### 5.5.5. Required Site Information

Design of an underground storage and retention system must carefully consider site conditions including soil, geology, and water table conditions. Specific data and analyses required for the design of an underground storage and retention system are set forth in [Appendix C](#).

#### 5.5.6. Construction requirements

The following construction procedures are required to avoid degradation of underground retention system infiltration capacity due to construction practices:

1. The location of underground retention system shall be clearly marked at the site to prevent unnecessary vehicular traffic across the area causing soil compaction.
2. During construction, erosion and sediment controls shall be used to minimize the amount of soil, especially the amount of fines, and debris entering the system.
3. During construction, inlet pipes shall be temporarily plugged, to prevent soil and debris from entering the system.
4. The underground retention system should not be placed into operation until the contributing drainage area is stabilized and the pretreatment sumps are constructed.

#### 5.5.7. Inspections, Operation and Maintenance

##### 1. General

Regular, routine inspection and maintenance is an important component of this type of underground system to ensure that it functions in a satisfactory manner. The maintenance intervals for an underground retention system are typically more frequent than standard “dry” retention ponds. The performance of the underground system will be related to the effectiveness of the up-gradient sediment/trash removal devices (refer to [Figures 6.4.2](#) and [6.4.3](#)), and the frequency of inspections and maintenance activities for each of the underground retention system’s components.

The guidelines outlined below are intended to provide a comprehensive schedule that gives reasonable assurance that the County requirements and recommendations are being met.

##### 2. Indication of system failure:

Standing water over sub-grade soils at the bottom of the underground retention system 72 hours after a storm event typically indicates system failure. Long term system failures are generally the result of inadequate/improper O&M procedures within the up-gradient sediment / trash removal devices, and/or within the underground retention system itself.

##### 3. Sub-grade Soil Maintenance

The sub-grade soils at the bottom of this system are the only mechanism to provide water quality treatment (soil infiltration of the RTV). Therefore, the designed hydraulic conductivity rates within this soil must be maintained. Inspection ports and access manholes/trench grates are provided to facilitate ongoing inspection and maintenance activities. Failure to repair inflow/outflow scour erosion damage, or to remove detrimental materials (i.e., trash, clays, lime



rock debris, organic matter, etc.), will result in lower soil hydraulic conductivity rates, and subsequent system failure. Manual methods can be used for this required maintenance. However, the use of a vacuum truck for contaminate removal may be a more practical means of providing for the removal of these detrimental materials and sediments. Disposal of these contaminates shall be in an approved landfill facility.

#### 4. Recommended inspection frequency

- *After a large storm event of greater than one (1) inch of rainfall:* To ensure the (continued) free flow of stormwater, inspect the system and remove accumulated trash and debris from the up-gradient sediment/trash removal devices, and the inflow and outflow points of the down-gradient underground retention system.
- *Every 6 months:* Perform a comprehensive inspection of the underground retention system for accumulated trash, debris and organic matter, and remove/dispose of these contaminates to ensure unimpeded stormwater flow. As appropriate, clean the surface of the sub-grade sands by raking, and check for accumulations in the various underground areas. If the sediment/contaminate accumulation is greater than two (2) inches, a vacuum truck and/or similar equipment may be necessary for removal operations. Removed contaminates shall be taken to an approved off-site landfill.
- *Annually, during September-November:* Monitoring of the drawdown time for the stormwater through the sub-grade sands shall be done to ensure recovery within 72 hours after the last rainfall event. Monitoring and observation of the drawdown times can be done visually through the inspection ports or observation well after a storm event. The drawdown of the water quality treatment volume (RTV) must recover within 72 hours after the storm event. If appropriate, post-construction hydraulic conductivity testing of the non-compacted soil floor [and their subsequent (certified) reports] shall be performed by the appropriate Florida licensed professional. Any post-construction soil testing reports shall be submitted to the County upon request.
- Drawdown times that exceed 72 hours are indicative of sub-grade clogging, and will likely require the removal of contaminates and raking of the sub-grade soils. The actual depth of removal can be done visually by looking at the discoloration of the entrapped fine silts, hydrocarbons (greases, oils), and organic matter. If required, replacement sub-grade soils must meet the design specifications under the original permit authorization.
- In addition to the sub-grade soils, other elements of the stormwater management system such as pipes, inlets, geotextile fabric, gravel, sediment/trash removal devices, etc., are to be inspected and repaired/replaced if needed.

#### 5. Recommended Maintenance Activities

- Monitor facility for sediment accumulation in the pipe (when used) and storage volume recovery (i.e., drawdown capacity). Observation wells and inspection ports should be checked following 3 days minimum dry weather. Failure to percolate stored runoff to the design treatment volume level within 72 hours indicates binding of soil within the system with fine solids. Reductions in storage volume due to sediment in the distribution pipe, also reduces efficiency. Minor maintenance measures can restore infiltration rates to acceptable levels short term. Major maintenance (total rehabilitation) is required to remove accumulated sediment in most cases or to restore recovery rate when minor measures are no longer effective or cannot be performed because of design configuration.

- Inspect appurtenances such as sedimentation and oil and grit separation traps or catch basins as well as diversion devices and overflow weirs when used. Diversion facilities and overflow weirs should be free of debris and ready for service. Sedimentation and oil/grit separators should be scheduled for cleaning when sediment depth approaches cleanout level. Cleanout levels should be established not less than 1 foot below control elevation of the chamber.
6. As-Needed To Prolong Service:
- Remove sediment from sediment or oil/grease traps, catch basin inlets, manholes, and other appurtenant structures and dispose of properly.
  - Remove debris from the outfall or “Smart Box” (diversion device in the case of off-line facilities).
7. As-Needed To Maintain 72-Hour Infiltration Rate:
- Periodic clean-out/rehabilitation of the system to remove any accumulated trash, sediment and other inflow debris and remediate any clogging of perforated pipes, aggregates and geotextile fabrics.
  - Total replacement of the system. In some cases, the system, may not be able to be rehabilitated sufficiently to restore the design storage and infiltration rate. In these cases, complete replacement of the system may be necessary. During replacement, any removed sediment, contaminated soil, coarse aggregate, and filter cloth shall be disposed of properly.

## 5.6. Bioretention and Rain Gardens

### 5.6.1. Description

Bioretention, or Rain gardens, are small retention basins that can be integrated into a site’s landscaping. Bioretention is a shallow, constructed depression that is planted with deep-rooted [Florida-friendly](#) or native plants. They can be located in the landscape or within parking lot islands to receive runoff from hard surfaces such as a roof, a sidewalk, a driveway, or parking area. Rain gardens slow down the rush of water from impervious surfaces, hold the water for a short time period, and allow it to naturally infiltrate into the ground or evaporate. The combination of soil, microbes and vegetation provide filtration, sedimentation, adsorption, ion exchange of solids and metals as well as biological absorption and decomposition of organics and nutrients present in the stormwater. Bioretention may include engineered media or Biosorption Activated Media (BAM) to enhance nitrogen removal in the Sensitive Karst Areas.



Rain gardens have multiple functions. They recharge the local aquifer by increasing the amount of water that filters into the ground; reduce the amount of stormwater pollutants – fertilizer, pesticides, car oil, etc. – that enter storm sewers or nearby surface water bodies; provide habitat for birds, butterflies, and beneficial insects; and improve property value by adding curb appeal to the landscape. Rain gardens are a beautiful and colorful way for homeowners, businesses and municipalities to help ease stormwater pollution problems. They typically are planted with native plants, providing benefits to wildlife, aesthetic benefits to neighborhoods, increased property values, and psychological benefits of green spaces to urban residents. A rain garden also conserves municipal water resources by reducing the need for potable water irrigation.

If the soil is not permeable enough, a second option is for the rain garden to be designed as a [biofiltration system](#) to function as a filter before water is conveyed downstream via an underdrain.

#### RAIN GARDEN SUMMARY

Advantages/Benefits	Reduces stormwater volume and pollutant loadings; provides ground water recharge and enhanced site aesthetics; integrate into site’s landscaping.
Disadvantages/Limitations	Small contributing drainage area. Do not construct within 75 feet of a public or private potable water supply well or within 15 feet

	of an on-site wastewater disposal and treatment system. Site must have appropriate soil and SHGWT conditions for infiltration.
Volume Reduction Potential	Medium
Pollutant Removal Potential	High for all pollutants
Key design considerations	<a href="#">SHGWT</a> at least 2 feet below bottom; recovery of treatment volume within 24 – 72 hours; plant with Florida-friendly plants appropriate for dry and wet conditions.
Key construction and maintenance considerations	Minimize soil compaction and sedimentation during construction; ensure design infiltration is met after construction; inspect during wet season to see if water is ponding and not infiltrating properly; restore mulch, remove weeds, and replant as necessary.

**Figure 5.6.1. Typical Cross-Section of a Rain Garden**

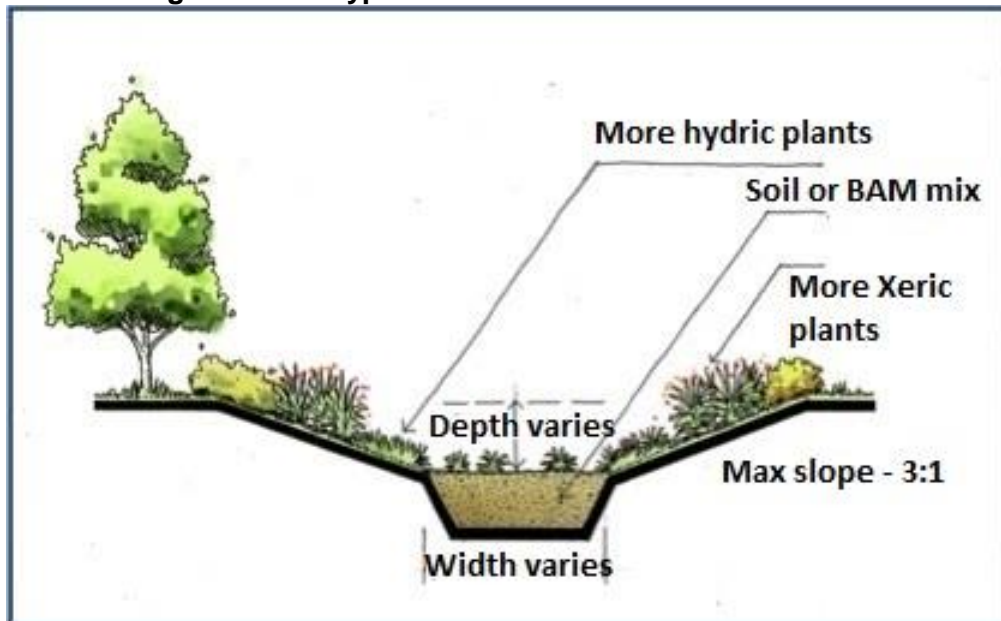

**5.6.2. Required Treatment Volume**

The Required Treatment Volume (RTV) necessary to achieve the desired treatment efficiency shall be routed to the rain garden and percolated into the ground. The required nutrient load reduction will be determined by type of waterbody to which the stormwater system discharges and the associated performance standard as set forth in [Section 4.3](#) of this Manual.

Treatment volumes to achieve the required load reduction efficiencies shall be determined based on the percentage of DCIA and the weighted Curve Number for non-DCIA areas as set forth in Table B1-1 and Table B2-1.

Rain gardens must be designed to have the capacity to retain the required treatment volume without considering discharges to ground or surface waters.

### 5.6.2. Calculating Load Reduction Efficiency for a Given Retention Volume

Use [Table B1-1](#) to determine the treatment volume needed to achieve an 80% pollutant load reduction if rain gardens are being used to fully achieve the required level of pollutant load reduction.

If rain gardens are being used as part of a BMP treatment train to achieve some level of pollutant load reduction but not the total amount of the required nutrient load reduction, use [Table B2-1](#).

### 5.6.3. Design Criteria

Follow the design criteria for Retention Basins in Section 6.3.4 and the following specific design criteria for rain gardens.

- 1. Maximum contributing drainage area** - Rain gardens shall be used only when the contributing drainage area is less than 3 acres.
- 2. Ponding depth** - Rain gardens shall have a minimum ponding depth of four inches and a maximum depth of 10 inches.
- 3. Location** - Rain garden shall be at least 10 feet away from a structure to prevent seepage or flooding. Do not locate the garden over a septic field. They must be at least 75 feet from a public or private potable well. Try to choose a naturally occurring low spot in the landscape or position the rain garden where gutter downspouts or sump pump outlet can be used to direct rainwater into the rain garden. Try to choose a location in the sun, either full or partial.
- 4. Measure drainage area and treatment volume.** - Determine the contributing drainage area and its runoff characteristics, then use Table B2-1 to determine the treatment volume and associated load reduction.
- 5. Topography** – Rain gardens are not recommended in areas where slopes are 10% or greater. Detailed engineering and geotechnical analysis must be completed prior to site clearing and implementation.
- 6. Depth of Water Table** – Rain gardens are not suitable if there is less than 2 feet of separation between the seasonal high water table and the bottom of the rain garden, unless an alternative design can be shown to be appropriate for the specific site.
- 7. Create a landscaping design** - Whether a rain garden is large or small the same basic principles apply. By planning the rain garden on paper first, one can create the best appearance possible for your rain garden.
- 8. Choose the plants** - [Florida-friendly plants](#) are suggested for rain garden installations because they are best adapted for the area. Choose plants (flowers and grasses) that will grow well in both wet and dry areas because the rain garden will temporarily fill with rainwater from time to time. Rain gardens rely on plants that will survive dry spells but then soak up excess stormwater during Florida's rainy months, preventing the water from running across your landscape. Include different types of plants in the rain garden to create a complete and cohesive look that will provide year-round interest. Suggested plants for Alachua County rain gardens are listed below. However, other species deemed appropriate may be used.



Suggested Rain Garden Plants for Alachua County		
	<i>Common Name</i>	<i>Botanical Name</i>
Flowers	African Iris	Dietes iridioides
	Blue Flag Iris*	Iris versicolor
	Canna Lily	Canna spp.
	Goldenrod*	Solidago spp.
	Milkweed	Asclepias spp.
	Shrimp Plant	Justicia brandegeana
	Swamp Flower*	Helianthus angustifolius
	Grasses & Shrubs	Florida gamma grass*
Muhly grass*		Muhlenbergia capillaris
Wiregrass*		Aristida stricta var. beyrichiana
Virginia Willow*		Itea virginica
Groundcover	Holly Fern	Cyrtomium falcatum
	Periwinkle	Vinca major
	St. Bernard's Lily	Anthericum sanderii

Notes: native plants designated by an asterisk (\*)

**Figure 5.6.2. Schematic and Photo of Rain Garden**

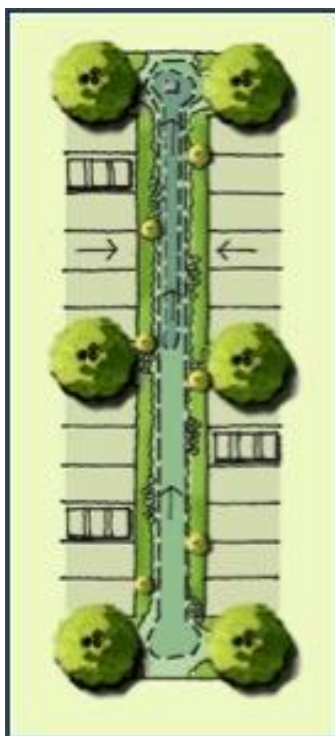

#### 5.6.4. Construction of the Rain Garden

1. **Lay out the garden** - Lay out the shape and boundary of the rain garden based on the design. Before digging contact your local organization that locates underground utilities.
2. **Excavate the garden** - If appropriate, remove and reuse existing turf grass. Excavate to a depth of 18 to 24 inches. Use the soil to build a berm around the rain garden edges if necessary.
3. **Prepare the soil** - Install the desired soil/media mixture that is appropriate for the plants. Use of compost or [BAM](#) is optional. If used, mix in well.
4. **Plant the flowers and grasses** - Follow the approved design and install plants in the approximate positions. Step back and look at the garden and the design. Plants should be placed about 1 foot apart from each other.
5. **Mulch the garden** - Use coarse, fibrous, shredded woodchips that won't float or blow away. Apply the mulch about 2-3 inches deep. This will help to keep the moisture in and the weeds out. Avoid cypress mulch because it is made by chopping down rare, old-growth cypress in wetlands.
6. **Water and ensure conveyance inflow** - After the rain garden is planted, water every other day for 2 weeks if it doesn't rain until garden looks to be growing on its own. Ensure that the conveyance system is delivering stormwater as desired and designed.

#### 5.6.5. Inspection and Maintenance

1. Inspect rain gardens at the beginning and the end of each rainy season. Remember rain gardens are not completely maintenance-free. After the rain garden is planted and established it may seldom need watering except in the dry season and it should never need any type of fertilizer or pesticide.
2. The soil's infiltration capacity must be inspected after a rain event to determine whether the treatment volume is being recovered as designed. This is best done toward the end of the rainy season.
3. Inspect for any erosion and repair as necessary.
4. Remove accumulated sediment, trash, and other litter.
5. It is important to weed, clean-up and re-mulch the rain garden, as needed, in the early Spring and Fall. Remove invasive plants and other weeds. Check the health of desirable plants and replace if necessary. Trim or thin excessive plant growth and remove decaying plant material.
6. During the first growing season, the most important maintenance is watering and weeding. A young garden will need about an inch of water per week until it is established. All rain gardens need constant weeding and replenishing of mulch. As the garden matures weeds will be pushed out by the growing plants. The mulch will need to be raked periodically and replenished or freshened every Spring.
7. Each Spring clean-up the rain garden by removing any dead material and replenishing the mulch. In the fall, it is important to remove some of the dead vegetation. You might wish to leave some of the material and seed bearing plants for bird habitat in the winter however.

## 5.7. Vegetated Swales

### 5.7.1. Description

Swales have been used for conveyance of stormwater along roads for decades. However, swales can also be used for stormwater treatment, especially as part of a BMP Treatment Train, when properly designed and maintained to provide retention and infiltration of stormwater.

Swales are defined in Chapter 403.803(14), Florida Statutes, as follows:

<p>“Swale” means a manmade trench which:</p> <ul style="list-style-type: none"> <li>• Has a top width to depth ratio of the cross-section equal to or greater than 6:1, or side slopes equal to or flatter than 3 feet horizontal to 1-foot vertical;</li> <li>• Contains contiguous areas of standing or flowing water only following a rainfall event;</li> <li>• Is planted with or has stabilized vegetation suitable for soil stabilization, stormwater treatment, and nutrient uptake; and</li> <li>• Is designed to take into account the soil erodibility, soil percolation, slope, slope length, and drainage area so as to prevent erosion and reduce pollutant</li> </ul>
--

Swales typically are online retention systems and their treatment effectiveness is directly related to the amount of the annual stormwater volume that is infiltrated. Swales designed for stormwater treatment can be classified into three categories:

- Swales with swale blocks or raised driveway culverts (Linear retention swale)
- Swales without swale blocks or raised driveway culverts (Conveyance swale)
- Swales incorporated into landscaping (an elongated rain garden)

### VEGETATED SWALE SUMMARY

Advantages/Benefits	Used as part of a BMP treatment train, sometimes for conveyance. Reduces stormwater volume, peak discharge rate, pollutant loadings, and heat island effect. Provides ground water recharge and enhanced site aesthetics. Can be integrated into the landscaping.
Disadvantages/Limitations	Do not construct within 75 feet of a public or private potable water supply well or within 15 feet of an on-site wastewater disposal and treatment system. Site must have appropriate soil and SHGWT conditions for infiltration. Not appropriate on sites with potential hazardous or toxic materials.
Volume Reduction Potential	Moderate to High depending on swale blocks
Pollutant Removal Potential	Moderate to High for all pollutants depending on swale blocks

<p>Key design considerations</p>	<p>Minimum infiltration rate through the vegetation and soil is at least one inch per hour; <a href="#">SHGWT</a> at least 2 feet below bottom; recovery of treatment volume within 24 – 72 hours; sides and bottoms must be stabilized with vegetation or other approved materials; bottom at least 2 feet wide for easier mowing.</p>
<p>Key construction and maintenance considerations</p>	<p>Minimize soil compaction and sedimentation during construction; ensure design infiltration is met after construction; inspect during wet season to see if water is ponding and not infiltrating properly; restore infiltration capacity as needed to meet permit requirements</p>

Figure 5.7.1. Typical Cross-section of a Conveyance Swale without Swale Blocks

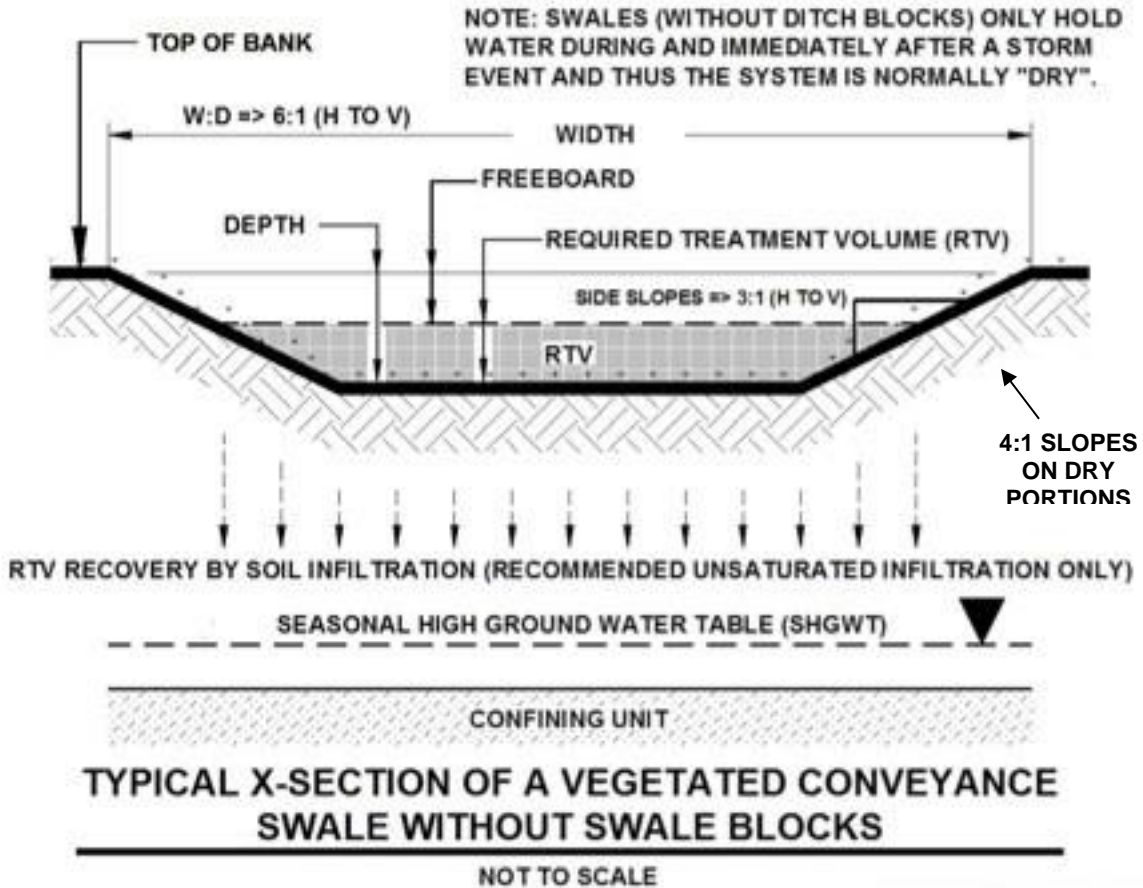

### 5.7.2. Swales with Swale Blocks or Raised Driveway Culverts (Linear Retention Systems)

A swale with swale blocks or raised driveway culverts essentially is a linear retention system in which the treatment volume is retained and allowed to percolate. The treatment volume necessary to achieve the required treatment efficiency shall be routed to the swale and percolated into the ground before discharge. Linear retention swales are designed following the requirements for retention systems in [Section 5.3](#) and the design criteria specific to swales in [Section 5.7.7](#) of this Manual. This type of swale system is recommended when multiple inflows occur to a swale.



### 5.7.3. Swales without Swale Blocks or Raised Driveway Culverts (Conveyance Swales)

Conveyance swales are designed and constructed to required dimensions to properly convey and infiltrate stormwater runoff as it travels through the swale. Conveyance swales may be useable in some projects as part of a BMP treatment train to provide pre-treatment of runoff before its release into another BMP depending upon the site conditions, the location of inflows, and the land use plan. These swales are designed to infiltrate a defined quantity of runoff (the treatment volume) through the permeable soils of the swale floor and side slopes into the shallow ground water aquifer immediately following a storm event (Figure 5.7.1).



Turf or other acceptable vegetation is established to prevent erosion, promote infiltration and stabilize the bottom and side slopes. Soil permeability and water table conditions must be such that the swale can percolate the required runoff volume. The swale holds water only during and immediately after a storm event, thus the system is normally “dry.” These types of swales are “open” conveyance systems. This means there are no physical barriers such as swale blocks or raised driveway culverts to impound the runoff in the swale prior to discharge to the receiving water. In these types of swales, the inflow of stormwater occurs at the “top” of the swale system and the retention volume and associated stormwater treatment credit is based on the infiltration that occurs as the stormwater moves down the swale.

### 5.7.4. Required Treatment Volume for Conveyance Swales

The required nutrient load reduction will be determined by the type of water body to which the swale and associated BMP treatment train discharges and the associated performance standard as set forth in [Section 5.3](#) of this Manual. Treatment volumes to achieve the desired load reduction efficiencies shall be routed to the swale and associated BMP treatment train before discharge. The nutrient load reduction credit assigned to the conveyance swale shall be based on the annual volume of stormwater that is retained in the swale and not discharged to the downstream BMP. This volume shall be calculated using the equations in Section 5.7.6.



**5.7.5. Calculating Load Reduction Efficiency for a Given Retention Volume**

Use [Table B1-1](#) to determine the treatment volume needed to achieve an 80% pollutant load reduction if linear retention swales are being used to fully achieve the required level of pollutant load reduction.

If linear retention swales are being used as part of a BMP treatment train to achieve some level of pollutant load reduction but not the total amount of the required nutrient load reduction use [Table B2-1](#).

**5.7.6. Calculating the Swale Length for Conveyance Swales**

The average flow rate through the swale and the length of swale needed to percolate a given volume of stormwater can be calculated using the two equations below.

**Equation 5.7.1.** Calculating the average flow rate:

This is calculated using the rational formula with the peak rate divided by 2 (average of triangular hydrograph).

$$Q = 0.5 CIA \qquad \text{Equation 5.7.1}$$

Where:

Q = Average flow rate

C = runoff coefficient

i = rainfall intensity (inches/hour) for the time of concentration

A = area of the swale being used for infiltration

**Equation 5.7.2.** Swale length for Trapezoidal Shaped Swales

$$L = \frac{43,200 Q}{\left\{ B + 2 \left( \frac{\left( 1.068 n Q (1 + Z^2)^{\frac{1}{3}} \right)^{\frac{3}{8}}}{S^{\frac{1}{2}} Z^{\frac{2}{3}} 2 [(1 + Z^2)^{\frac{1}{2}} - Z]} \right) (1 + S^2)^{\frac{1}{2}} \right\} i}$$

Where:

L = Length of swale (ft)

B = Bottom width of swale (ft)

Q = Average flow rate (cfs) from Equation 6.7.1

n = Manning’s Roughness Coefficient

Z = Side slope (horizontal distance for a one foot vertical change)

S = Longitudinal slope

i = Limiting infiltration rate of swale (inches/hour)

### 5.7.7. Design Criteria for Swales

1. Conveyance swales will be designed to infiltrate the required volume of stormwater needed to achieve the desired level of nutrient load reduction before discharging to the downstream BMP. Linear retention swales shall be designed to infiltrate the required treatment volume as for retention systems as specified in Section 6.3.2 of this Manual.
2. The seasonal high ground water table shall be at least two feet below the bottom of the swale unless the applicant demonstrates based on plans, test results, calculations or other information that an alternative design is appropriate for the specific site conditions.
3. The minimum infiltration rate through the vegetation and soil shall be at least one inch per hour.
4. The lateral slope across the bottom of the swale shall be flat to assure even sheet flow and prevent channelized flow and erosion.
5. Longitudinal slopes shall not be so steep as to cause erosive flow velocities.
6. It is recommended that the bottom of the swale be at least two feet wide to facilitate mowing.
7. Off-street parking or other activities that can cause rutting or soil compaction is prohibited.
8. Swales shall not be constructed within 75 feet of a public or private potable water supply well or within 15 feet of an on-site wastewater disposal and treatment system.

### 5.7.8. Soil Requirements and Testing Requirements

Swales shall be constructed on soils that can infiltrate the required treatment volume. Geo-technical testing of the underlying soil will be required to establish the depth to the Seasonal High Ground Water Table (SHGWT), the limiting infiltration rate (constant rate with time), and identification of the location of close-to-surface impermeable materials or layers that may require re-location of the swale. Details related to safety factors, recovery/mounding analysis and supporting soil testing is provided in [Appendix C](#) of this Manual.

### 5.7.9. Construction and Stabilization Requirements

The following construction procedures are required to avoid degradation of the swale's infiltration capacity due to construction practices:

1. The location and dimensions of the swale system shall be verified on-site prior to its construction. All design requirements including swale dimensions and distances to foundations, septic systems, and wells need to be verified.
2. The location of swales shall be clearly marked at the site to prevent unnecessary vehicular traffic across the area causing soil compaction.
3. Excavation shall be done by lightweight equipment to minimize soil compaction. Tracked, cleated equipment does less soil compaction than equipment with tires.
4. Ensure that lateral and longitudinal slopes meet permitted design requirements and will not erode due to channelized flow or excessive flow rates.
5. Final grading and planting of the swale should not occur until the adjoining areas draining into the swale are stabilized. Any accumulation of sediments that does occur must be removed during the final stages of grading. The bottom should be tilled to produce a highly porous surface.
6. Ensure that measures are in place to divert runoff while vegetation is being established on the side slopes and bottom of the swale. If runoff can't be diverted, vegetation shall be established by staked sodding or by using erosion control blankets or other appropriate methods.
7. Ensure that the vegetation used in the swale is consistent with values used for Manning's "n" in the design calculations.

8. An applicant may propose alternative construction procedures to assure that the design infiltration rate of the constructed and stabilized swale system basin is met provided it is acceptable and approved by the County.

#### 5.7.10. Inspections, Operation and Maintenance Requirements

Maintenance issues associated with swales are related to clogging of the porous soils which reduces or prevents infiltration thereby slowing recovery of the stormwater treatment volume and often resulting in standing water. Clogging can result from erosion and sedimentation and the resulting sealing of the bottom or side slope soils. It can also occur from excessive loading of oils and greases or from excessive algal or microorganism growth.

To determine if a swale is properly functioning or whether it needs maintenance requires that an inspection be done during and soon after a storm. The inspection should determine if the swale is recovering its storage volume within its permitted time frames, generally 24 to 72 hours after a storm. If this is not occurring and results in standing water, then the cause of clogging must be determined and appropriate actions undertaken beginning with those specified in the system's Operation and Maintenance Plan.

##### 1. Inspection Items:

- Inspect swale for storage volume recovery within the permitted time, generally less than 72 hours. Failure to percolate the required treatment volumes indicates reduction of the infiltration rate and a need to restore system permeability
- Inspect and monitor sediment accumulation on the bottom of the swale or at inflows to prevent clogging of the swale or the inflow pipes.
- Inspect vegetation of bottom and side slopes to assure it is healthy, maintaining coverage, and that no erosion is occurring within the swale.
- Inspect the swale for potential mosquito breeding areas such as where standing water occurs after 72 hours or where cattails or other invasive vegetation becomes established.
- Inspect swale to determine if filling, excavation, construction of fences, or other objects are obstructing the surface water flow in the swales.
- Inspect the swale to determine if it has been damaged, whether by natural or human activities.

##### 2. Maintenance Activities As-Needed To Prolong Service:

- If needed, restore infiltration capability of the swale to assure it meets permitted requirements.
- Remove accumulated sediment from swale and inflow or outflows and dispose of properly. Please note that stormwater sediment disposal may be regulated under [Chapter 62-701](#), F.A.C. Sediment removal should be done when the swale is dry and when the sediments are cracking.
- Remove trash and debris, especially from inflow or outflow structures, to prevent clogging or impeding flow.
- Maintain healthy vegetative cover to prevent erosion of the swale bottom or side slopes. Mow grass as needed and remove grass clippings to reduce nutrient loadings.
- Eliminate mosquito-breeding habitats.
- Remove fences or other obstructions that may have been built in the swale system.
- Repair any damages to the swale system so that it meets permitted requirements.

## 5.8. Vegetated Natural Buffers

### 5.8.1. Description

Vegetated natural buffers (VNBs) are defined as areas with vegetation suitable for sediment removal along with nutrient uptake and soil stabilization that are set aside between developed areas and a receiving water or wetland for stormwater treatment purposes. Typically, they are a [retention BMP](#). They also can be used as the prefilter for other BMPs. Under certain conditions, VNBs are an effective best management practice for the control of nonpoint source pollutants in overland flow by providing opportunities for filtration, deposition, infiltration, absorption, adsorption, decomposition, and volatilization.

VNBs are most commonly used as an alternative to swale/ berm systems installed between backyards and the receiving water. Buffers are intended for use to avoid the difficulties associated with the construction and maintenance of backyard swales on land controlled by individual homeowners. Potential impacts to adjacent wetlands and upland natural areas are reduced because fill is not required to establish grades that direct stormwater flow from the back of the lot towards the front for collection in the primary stormwater management system. In addition, impacts are potentially reduced since buffer strips can serve as wildlife corridors, reduce noise, and reduce the potential for siltation into receiving waters.

Vegetative natural buffers are not intended to be the primary stormwater management system for residential developments. They are most commonly used only to treat those rear-lot portions of the development that cannot be feasibly routed to the system serving the roads and fronts of lots. A schematic of a typical VNB and its contributing area is presented in Figure 5.8.1. The use of a VNB in combination with a primary stormwater management system for other types of development shall only be allowed if the applicant demonstrates that there are no practical alternatives for those portions of the project, and only if the VNB and contributing areas meet all of the requirements in this section of the Manual.

#### VEGETATED NATURAL BUFFER SUMMARY

Advantages/Benefits	Reduces stormwater volume, pollutant loadings, and heat island effect. Provides ground water recharge and enhanced site aesthetics.
Disadvantages/Limitations	Used to treat rear roof and rear yard runoff, especially for waterfront lots. Do not construct within 75 feet of a public or private potable water supply well or within 15 feet of an on-site wastewater disposal and treatment system. Site must have appropriate soil and SHGWT conditions for infiltration.
Volume Reduction Potential	Low to Moderate depending on site conditions and flow length
Pollutant Removal Potential	Low to Moderate for all pollutants

<p>Key design considerations</p>	<p>Legal reservation of the VNB required; must have shallow sheet flow; minimum width of 25 feet; minimum length equal to the length of the contributing runoff area with maximum length of 100 feet; minimum infiltration rate through the vegetation and soil is at least one inch per hour; <a href="#">SHGWT</a> at least 2 feet below bottom; recovery of treatment volume within 24 – 72 hours; sides and bottoms must be stabilized with natural or Florida-friendly vegetation</p>
<p>Key construction and maintenance considerations</p>	<p>Minimize disturbance of vegetation during construction; ensure design infiltration is met after construction; inspect during wet season to see if water is ponding and not infiltrating properly; restore infiltration capacity as needed to meet permit requirements; maintain vegetation as necessary.</p>

**Figure 5.8.1. Plan View Schematic of Typical Vegetative Natural Buffer**

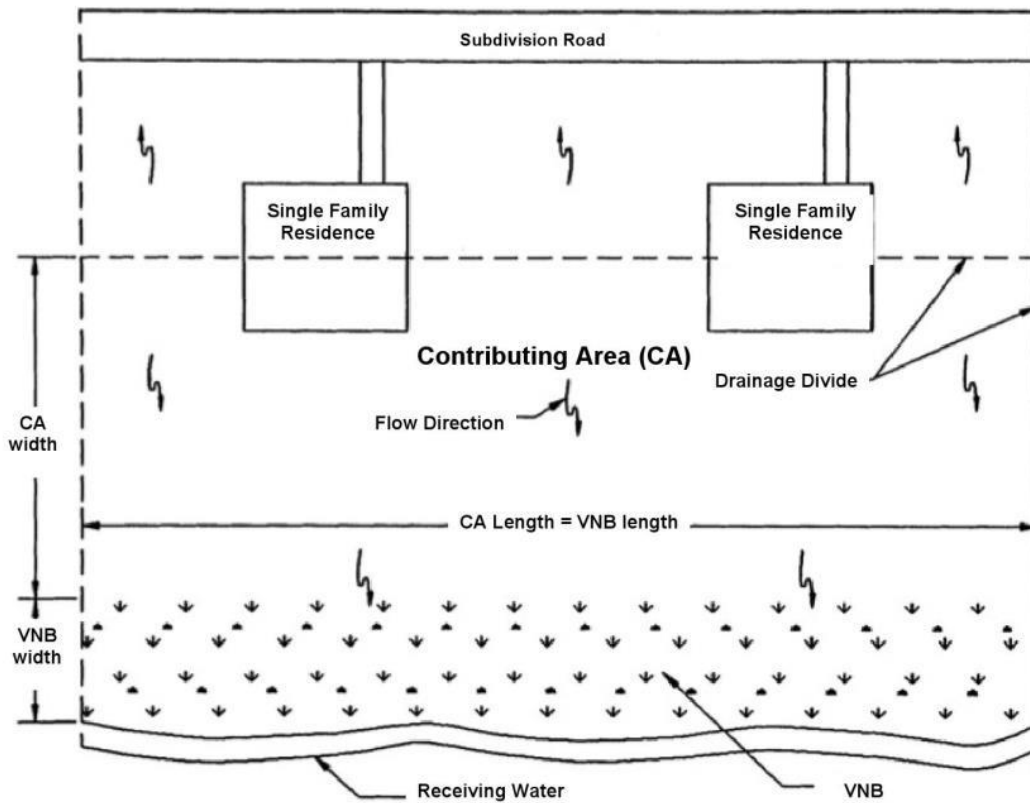



### 5.8.2. Required Treatment

The treatment volume necessary to achieve the desired treatment efficiency shall be routed to the Vegetated Natural Buffer and percolated into the ground. The required nutrient load reduction will be determined by type of water body to which the stormwater system discharges and the associated performance standard as set forth in [Section 5.3](#) of this Manual

Treatment volumes to achieve the required load reduction efficiencies shall be determined based on the percentage of DCIA and the weighted Curve Number for non-DCIA areas as set forth in Table B1-1 and Table B2-1.

Natural areas adjacent to rear-lots that have good infiltration potential are candidates for use as VNBs. Runoff from the rear-lot areas must be designed to percolate a specified portion of runoff as indicated below.

### 5.8.3. Calculating Load Reduction Efficiency for a Given Retention Volume

Use [Table B1-1](#) to determine the treatment volume needed to achieve an 80% pollutant load reduction if Vegetative Natural Buffers are being used to fully achieve the required level of pollutant load reduction.

When Vegetated Natural Buffers are being used as part of a BMP treatment train to achieve some level of pollutant load reduction but not the total amount of the required nutrient load reduction, use [Table B2-1](#).

### 5.8.4. Design Criteria

1. Vegetated Natural Buffers shall be designed to infiltrate the required treatment volume as specified in Section 6.8.2 of this Manual.
2. The contributing area is defined as the area that drains to the VNB. Only rear-lots of residential areas can contribute runoff to a VNB and then only if routing the runoff from such areas to the primary [stormwater management system](#) serving the development is not practical.
3. The maximum width (dimension parallel to the flow direction) of the contributing area is 300 feet. No fertilizer shall be applied in the contributing area unless soil and leaf tissue analyses indicate a need for fertilizer to ensure healthy plant growth. Only [Florida-friendly fertilizers](#) shall be applied by certified commercial applicators.
4. The seasonal high ground water table shall be at least two feet below the bottom of the vegetated natural buffer unless the applicant demonstrates based on plans, test results, calculations or other information that an alternative design is appropriate for the specific site conditions.
5. The minimum infiltration rate through the vegetation and soil shall be at least one inch per hour.
6. The minimum buffer width (dimension parallel to flow direction) shall be 25 feet to provide adequate area for infiltration. The maximum VNB width shall be 100 feet to ensure sheet flow conditions and the integrity of the treatment system. Factors affecting the minimum width (measured parallel to the direction of runoff flow) of VNB include infiltration rate, ground slope, rainfall, cover and soil characteristics, depth to water table and overland flow length. Infiltration is the primary means of treatment in vegetated natural buffers
7. The maximum slope of VNB shall not be greater than 6:1.
8. The length of the buffer (measured perpendicular to the runoff flow direction) must equal the length of the contributing runoff area (see Figure 6.8.1).

9. Runoff from the adjacent contributing area must be evenly distributed across the buffer strip to promote overland sheet flow. If the flow regime changes from overland to shallow concentrated flow, the buffer is effectively “short-circuited” and will not perform as designed.
10. The VNB area will be an existing undeveloped area that contains existing or planted vegetation suitable for infiltrating stormwater and soil stabilization. The existing vegetation, except exotic species, must not be disturbed during or after the construction of the project. If the VNB will be planted, the proposed list of [Florida-friendly plants](#) must be submitted to the County for review. Maintenance shall assure that the VNB contains less than 10 percent coverage by exotic or nuisance plant species.
11. Erosion control measures as specified in [Section 3.7](#) of this Manual must be used during development of the contributing area to prevent erosion or sedimentation of the vegetated natural buffer.
12. Vegetated natural buffers shall not be constructed within 75 feet of a public or private potable water supply well or within 15 feet of an on-site wastewater disposal and treatment system.
13. The vegetated natural buffer and any required wetland buffer can be the same area provided the functions and regulatory requirements for each are met.
14. The Property Association Documents and Conditions Covenants and Restrictions (CC&R’s) will require that the contributing area must be stabilized with permanent vegetative cover that is consistent with the Florida Friendly Landscaping program and which is fertilized only with Florida-friendly fertilizers based on soil testing.
15. The reservation must also include access for maintenance of the VNB unless the operation and maintenance entity wholly owns or retains ownership of the property.

#### **5.8.5. Required Site Information**

Successful design of a Vegetated Natural Buffer system depends heavily upon conditions at the site, especially information about the soil, geology, and water table conditions. Specific data and analyses required for the design of a retention system are set forth in [Appendix C](#) of this Manual.

#### **5.8.6. Construction Requirements**

The following construction procedures are required to protect the Vegetated Natural Buffer during planting, if needed, and to avoid degradation of the VNB due to construction of the adjacent contributing area:

1. The location and dimensions of the VNB shall be verified on-site prior to any construction. All design requirements including VNB dimensions and distances to foundations, septic systems, wells, etc. need to be verified.
2. The VNB shall be clearly marked at the site to prevent equipment or vehicular traffic from entering the VNB (if a natural area) or to minimize compaction from any equipment entering the VNB during planting or establishment.
3. Ensure that the VNB buffer length, width, and slopes meet permitted design requirements.
4. Ensure that the VNB will not erode due to channelized flow or excessive flow rates.
5. Ensure that measures are in place to divert runoff from the VNB while the adjacent contributing area is being cleared and established. The adjacent contributing area shall be stabilized as quickly as possible by sodding or using erosion control blankets or other appropriate methods.
6. Ensure that the vegetation planted in the VNB and adjacent contributing area meets Florida-friendly landscaping™ requirements and that all exotic plants are removed as specified in the permitted design.

### 5.8.7. Inspections, Operation and Maintenance

Maintenance issues associated with Vegetated Natural Buffers are related to integrity of the VNB and damage to the natural or planted vegetation or the infiltration capabilities within the VNB. To determine if the VNB is properly functioning or whether it needs maintenance requires that an inspection be done during and soon after a storm. The inspection should determine if the VNB is providing sheet flow and infiltration of the required treatment volume within its permitted time frames, generally 24 to 72 hours after a storm. If this is not occurring, then the cause of must be determined and appropriate actions undertaken beginning with those specified in the system's Operation and Maintenance Plan.

VNBs must be inspected annually by the operation and maintenance entity to determine if there has been any encroachment or violation of the terms and condition of the VNB as described below. Reports documenting the results of annual inspections shall be filed with the County every three years, or upon discovery of any encroachment or violation of design parameters, whichever occurs first.

#### 1. Inspection Items:

- Inspect VNB for storage volume recovery within the permitted time, generally less than 72 hours. Failure to percolate the required treatment volumes indicates reduction of the infiltration rate and a need to restore system permeability.
- Inspect VNB to assure that inflow is via sheetflow, for areas of channelized flow through or around the buffer, and for areas with erosion or sediment accumulation indicating channelized flow or that stabilization of the adjacent contributing area is needed.
- Inspect VNB for damage by foot or vehicular traffic or encroachment by adjacent property owners.
- Inspect VNB for any signs of erosion or sedimentation.
- Inspect VNB for the health and density of vegetation, and for the occurrence of exotic or nuisance plant species.

#### 2. Maintenance Activities As-Needed To Prolong Service:

- If needed, restore infiltration capability of the VNB to assure it meets permitted requirements.
- Repair any areas where channelized flow is occurring and restore sheetflow.
- Repair any areas with erosion and carefully remove accumulated sediments if needed to assure the health and functioning of the VNB
- Stabilize eroding parts of the adjacent contributing area as needed to prevent erosion and sedimentation.
- Repair any damage to the VNB by foot or vehicular traffic and remove any fences or other materials that have been placed in the VNB by adjacent property owners.
- Maintain the VNB vegetation and, if necessary, replant the VNB with approved Florida-friendly vegetation as needed to assure sheet flow and prevent erosion and sedimentation. Remove any exotic or nuisance species from the VNB including those listed on Table 406.16.2, Discouraged Non-Native Vegetation, in Chapter 406 of Article 2 of the ULDC.

All repairs to the VNB must be made as soon as practical to prevent additional damage to the buffer. Repaired areas must be re-established with approved Florida-friendly or native vegetation.



## 5.9. Pervious Pavement Systems

### 5.9.1. Description

Pervious pavement systems include the subsoil, the sub-base, and the pervious pavement (Figure 5.9.1). They can include several types of materials or designed systems such as pervious concrete, pervious aggregate/binder products, pervious paver systems, and modular paver systems. Pervious asphalt and pervious pavements using crushed and recycled glass will not be allowed unless product-specific information and verification testing results are provided to demonstrate sufficient structural capability and hydraulic performance. Recent studies on the design, longevity, and infiltration characteristics of pervious pavement systems are available on the University of Central Florida Stormwater Academy’s website <http://stormwater.ucf.edu/>.

Pervious pavement systems are retention systems. They should be used as part of a treatment train to reduce stormwater volume and pollutant load from parking lots, or similar types of areas. As with all infiltration BMPs, the treatment efficiency is based on the amount of the annual runoff volume infiltrated which depends on the available storage volume within the pavement system, the underlying soil permeability, and the ability of the system to readily recover this volume.

#### PERVIOUS PAVEMENT SUMMARY

Advantages/Benefits	Reduces site imperviousness, stormwater volume, peak discharge rate, pollutant loadings, temperature, and heat island effect. Provides ground water recharge. Increases development potential of site.
Disadvantages/Limitations	More expensive than traditional pavement and more difficult to install and maintain. Limited to low traffic areas with limited structural load. Possible ADA issues for handicapped. Do not construct within 75 feet of a public or private potable water supply well or within 15 feet of an on-site wastewater disposal and treatment system. Site must have appropriate soil and SHGWT conditions for infiltration. Not appropriate on sites with potential hazardous or toxic materials.
Volume Reduction Potential	Moderate to High depending on area with pervious pavement
Pollutant Removal Potential	Moderate to High for all pollutants
Key design considerations	Must use certified installer. Must use on areas with flat or minimal slope. Must incorporate perimeter edge restraint. Must use in-situ infiltration measurements. Must have minimum 2"/hr infiltration rate through the entire system. <a href="#">SHGWT</a> at least 2 feet below bottom; recovery of treatment volume within 24 – 72 hours;



<p>Key construction and maintenance considerations</p>	<p>Minimize soil compaction and sedimentation during construction; ensure design infiltration is met after construction; inspect during wet season to see if water is ponding and not infiltrating properly; use regular vacuum sweeping to minimize clogging and maintain infiltration capacity as needed to meet permit requirements; must maintain at least 2"/hr percolation rate; areas with high levels of wind-blown sediments (e.g., near the beach) may create maintenance issues.</p>
--	---

Figure 5.9.1. Typical Pervious Pavement Cross Section

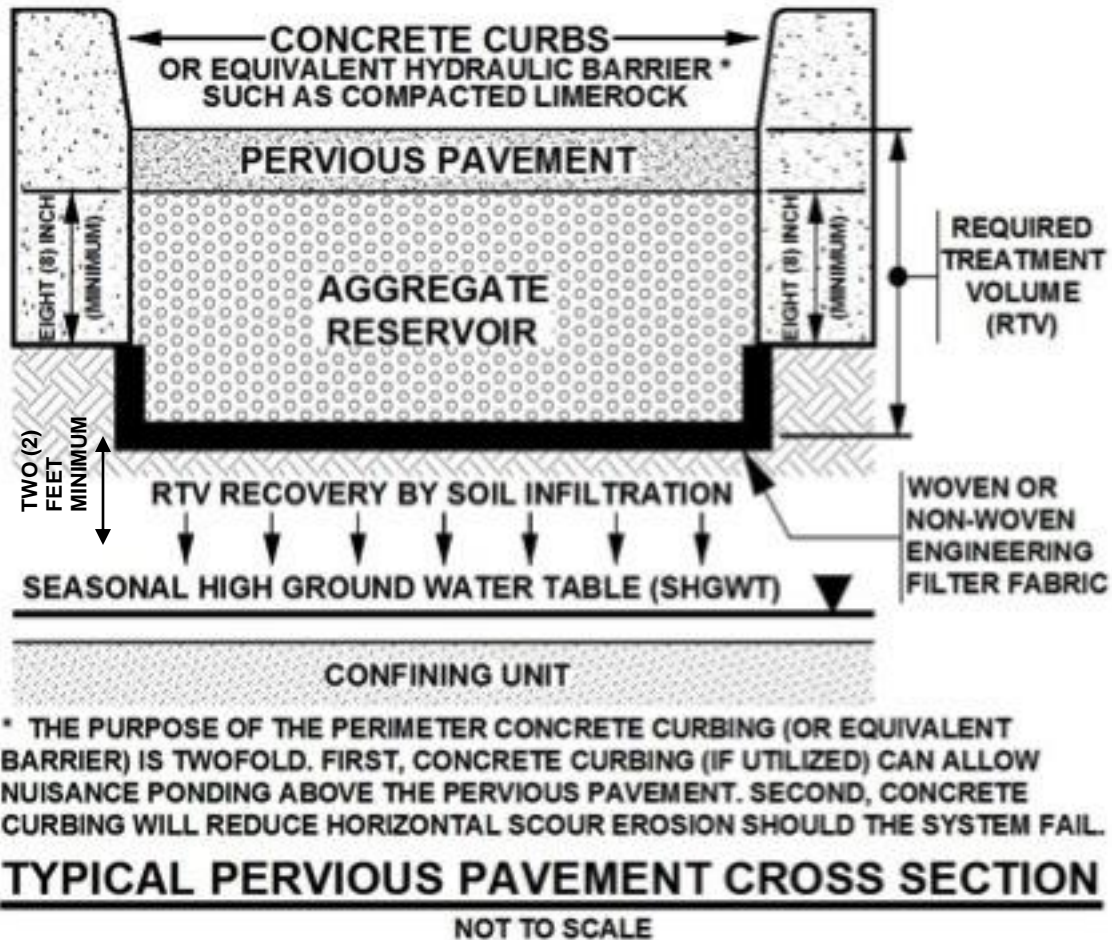

**5.9.2. Applicability**

Pervious pavement systems can be used for many impervious applications (i.e. sidewalks, driveways, on-street parking) but they primarily are used in parking lots, especially the parking stalls. Typically, pervious pavements are used in areas with low-traffic volume, low truck traffic, and low number of turning areas. To address these concerns, pervious pavements often are integrated with traditional impervious pavements such as within a parking lot where the parking stalls are pervious pavements. The designer must consider the limitations of the pervious

pavement system application in determining its proper application. In addition, the designer must consider various site conditions and potential challenges including:

1. Poorly draining soils such as those with shallow Seasonal High Ground Water Tables (SHGWTs), shallow confining units (i.e., clays/hardpans), organic mucks, etc.
2. In areas subject to high traffic volumes, regardless of wheel loads. It is recommended that:
  - The number of vehicles using a pervious pavement parking stall should not exceed one hundred (100) vehicles per day for most pervious pavement systems.
  - Traditional Class I concrete, brick pavers, or an appropriate asphalt section should be used in areas subject to high traffic volumes such as the primary driving areas within a parking lot.
3. Regardless of wheel loads, pervious pavement should not be used on areas of frequent turning movements (public roadways, drive thru lanes, around gas pumps, adjacent to dumpster pads, driveway entrances, etc.). It is recommended that traditional Class I concrete, brick pavers or an appropriate asphalt section be used in these areas.
4. If pervious pavement is proposed for areas with heavy wheel loads or other non-recommended conditions, then the applicant shall be required to use alternate methods of pavement design. This may include using imported (hydraulically clean) soils, structural/permeable geo-fabrics, thicker pervious pavement sections, etc. above the parent soil. Hydraulically clean soils will be defined as those that are free of materials (clays, organics, etc.) that will impede the soil's saturated vertical and horizontal hydraulic conductivity.
5. Pervious pavements shall not be used in areas with high potential for hazardous material spills that could seep into the underlying ground water. Examples of these areas include (but are not limited to) auto maintenance facilities, auto parts stores that are subject to on-site installation of hazardous materials by customers/store personnel, chemical plants, etc.
6. Certain pervious pavement systems may create the potential for tripping hazards that needs to be considered when designing areas used by pedestrians or the handicapped.
7. Any underground treatment systems should not be located directly under pervious pavement.

### 5.9.3. Required Treatment Volume

The treatment volume necessary to achieve the desired treatment efficiency shall be routed to the pervious pavement system and percolated into the ground. The required nutrient load reduction will be determined by type of water body to which the stormwater system discharges and the associated performance standard as set forth in [Section 4.3](#) of this Manual.

Treatments volumes to achieve the required load reduction efficiencies shall be determined based on the percentage of DCIA and the weighted Curve Number for non-DCIA areas as set forth in Table B1-1 and Table B2-1.

### 5.9.4. Calculating Load Reduction Efficiency for a Given Retention Volume

Use [Table B1-1](#) to determine the treatment volume needed to achieve an 80% pollutant load reduction if pervious pavement systems are being used to fully achieve the required level of pollutant load reduction.

If retention basins are being used as part of a BMP treatment train to achieve some level of pollutant load reduction but not the total amount of the required nutrient load reduction, use [Table B2-1](#).

### 5.9.5. Design Criteria

Pervious pavement system design has two major components: structural and hydraulic. The pervious pavement system must be able to support the traffic loading while also (and equally important) functioning properly hydraulically. This section does NOT discuss structural designs of pervious pavement systems. Stormwater system designers and engineering consultants should consult the product manufacturer's pavement design standards to ensure that pervious pavements will be structurally stable, and not be subject to premature deterioration failure.

Below are the types of practices, specifications, recommendations, tools and potential conditions for applicants to consider for the approval of pervious pavement systems. This is not intended to cover all potential designs. Professional judgment must be used in the design and review of proposed pervious pavement systems.

1. Pervious pavement systems must have the capacity to retain the required treatment volume without a discharge and without considering soil storage.
2. The applicant must provide reasonable assurance that a **contractor, trained and certified by the product manufacturer, will install** the proposed pervious pavement system. To accomplish this requirement, the applicant must supply documentation of the appropriate contractor certification as part of the site plan process. If the pervious pavement contractor is not known at the time of site plan submittal, a special condition shall be placed in the site plan approval to require submittal of the contractor's certification prior to construction commencement.
3. The seasonal high ground water table shall be at least two feet beneath the bottom of the pervious pavement system unless the applicant demonstrates, based on plans, test results, calculations or other information, that an alternative design is appropriate for the specific site conditions. The "system" is defined as the pervious pavement itself, the underlying storage reservoir, if used (i.e., pea rock, #57 stone, etc.), and the geo-fabric that wraps the underlying storage reservoir (refer to [Figures 6.9.1](#) through [6.9.4](#) for additional information).
4. The pervious pavement system must provide the capacity for the recovery of the required treatment volume of stormwater within 72 hours, with a safety factor of two, assuming average Antecedent Runoff Condition (ARC 2). In a pervious pavement system, the stormwater is drawn down by natural soil infiltration and dissipation into the ground water table, as opposed to underdrain systems which rely on artificial methods like perforated or slotted drainage pipes. A drawdown or recovery analysis is required that accounts for the mounding of ground water beneath the pervious pavement system. Details related to safety factors, recovery/mounding analysis and supporting soil testing is provided in [Appendix C](#) of this Manual.
5. The minimum vertical hydraulic conductivity of the pervious pavement system shall not be less than 2.0 inches per hour.
6. Pervious pavement systems shall not be constructed within 75 feet of a public or private potable water supply well or within 15 feet of an on-site wastewater disposal and treatment system.
7. The in-situ (or imported) subgrade soil (below the pervious pavement system) shall be compacted to a maximum of 92% - 95% Modified Proctor density (ASTM D-1557) to a minimum depth of 24 inches. For proposed pervious pavements within redevelopment projects, the existing pavement section and its compacted base shall be removed. The

- underlying soils are to be scarified to a minimum 16 inch depth, re-graded, filled with hydraulically clean soils (if applicable) and proof rolled to a maximum compaction of 92% - 95% Modified Proctor density (ASTM D-1557).
8. Other than pedestrian walks, bicycle paths and driveway ingress or egress areas, the maximum slope for pervious pavements is 1/8 inch per foot (1.04%) although zero % slope is preferred. Steeper slopes (greater than 1/8 inch per foot) will be considered by the County but must be justified by the applicant as part of the site plan review process by providing plans, monitoring data, test results, or other information that demonstrates that the steeper slopes are appropriate for the specific site conditions and provides equivalent treatment and protection. The primary issue of concern is the hydraulic ability of the pervious pavement system to percolate the Required Treatment Volume (RTV) into the underlying sub-soil.
  9. Except for pervious walks and bike paths, curbing, edge constraint or other equivalent hydraulic barrier will be required around the pervious pavement to a minimum depth of eight (8) inches beneath the bottom of the pavement and to the depth necessary to prevent scouring from the horizontal movement of water below the pavement surface depending on the adjacent slopes. Refer to [Figures 5.9.1](#) through [5.9.4](#) for additional information. Another option is to create check dams within the aggregate reservoir that will reduce runoff velocity and the potential for scour.
  10. The horizontal movement of water can cause scour failure at the edge of the pervious pavement system, or mask the hydraulic failure of the system due to plugging of the deeper voids in the pervious pavement or aggregate reservoir. The cross-sectional construction drawings of the pervious pavement system and its relationship to the slopes of adjacent areas must include a demonstration that the depth of the curbing, edge constraint or other equivalent hydraulic barrier is sufficient to prevent erosion and scour. As an option, the delineated areas of nuisance ponding can be shown on the supporting stormwater application sketches or drawings.
  11. To provide an indicator that the pervious pavement system has failed or needs maintenance, the system shall be designed to allow a minimum ponding depth of one (1) inch and a maximum ponding depth of two (2) inches prior to down-gradient discharge. This doesn't apply to pervious walks and bicycle paths (see Figures 6.9.1 through 6.9.4). The permitted construction plans shall delineate the areas of pervious pavement that may be subject to nuisance ponding. As an option, the delineated areas of nuisance ponding can be shown on the supporting ERP application sketches or drawings.
  12. The pervious pavement system must be designed to have an overflow at the nuisance ponding elevation to the down-gradient stormwater treatment or attenuation system or outfall (see [Figures 5.9.2](#) through [5.9.4](#)).
  13. Erosion and sediment controls on adjacent landscaped areas must be kept in place until the entire contributing area is stabilized. Runoff from adjacent landscaped areas must NOT be directed onto pervious pavement system areas unless the Applicant demonstrates that the off-site areas that drain onto the pervious pavement will not increase sediment, silt, sand, or organic debris that increases the potential for clogging the pervious pavement. The design must minimize the likelihood of silts and sands from plugging the pavement void spaces (see [Figures 5.9.7](#) through [5.9.9](#)).
  14. Except for pervious walks and bicycle paths, the installation of Embedded Ring Infiltrometer Kit (ERIK) is required (see [Figures 5.9.5](#) and [5.9.6](#)). A minimum one (1) ERIK in-situ infiltrometer will be required for each section of pervious pavement installed. For larger sections, a minimum of two (2) in-situ ERIK infiltrometers per acre of pervious pavement will be required. ERIK Infiltrometers shall be placed in the lowest part of the pervious parking area where ponding will occur if the pavement fails to infiltrate properly. The location of the ERIK infiltrometers shall be shown on the construction plans or other supporting sketches or drawings for the project.

15. Documentation of ERIK infiltrometer construction, and post-construction testing, shall be required with submittal of the construction completion certification. Test results shall be provided in report form, certified by the appropriate Florida Registered Professional. The construction completion certification shall not be accepted if the vertical hydraulic conductivity is less than 2.0 inches per hour or is less than the permitted design percolation rate in any of the required ERIK infiltrometers, as appropriate.
16. For proper maintenance of most pervious pavement systems, periodic vacuum sweeping is recommended. At a minimum, vacuum sweeping is required annually but frequency depends on traffic volume and runoff contributions from adjacent landscaping. If ERIK tests indicate a vertical hydraulic conductivity rate less than 2.0 inches per hour, or is less than the permitted design percolation rate, or when nuisance ponding occurs, vacuum sweeping is required. Vacuum sweeping is required for areas that are subject to wind transported soils (near sand dunes or other coastal areas) or other conditions where excessive soil or other debris deposition is expected to occur (from adjacent landscaping mulch and leaf litter, from areas with high leaf fall, fugitive sands and lime rock fines from adjacent construction sites).
17. A remediation plan shall be submitted to the County for implementation by the permittee should vacuum sweeping fail to improve the vertical hydraulic conductivity to a rate greater than 2.0 inches per hour, or equal to or greater than the permitted design percolation rate, or resolve the nuisance ponding. The remediation plan shall be prepared and submitted to the County for review and approval. Maintenance records shall be retained by the permittee and made available to the County as part of the required O&M re-inspections and certifications.
18. Entrances to pervious pavement areas shall be posted by signs to inform users they are entering a pervious pavement area and that any vehicles with heavy wheel loads or with muddy tires should not enter.
19. Water quality credit for pervious pavement walks and bicycle paths:  
For the purposes of this section, pervious pavement walks and bicycle paths refer to linear pathways and exclude areas such as courtyards and patio areas. To encourage the use of pervious pavement, the following credits are established for pervious pavement walks and bicycle paths:
  - For soils with SHGWT depths of 0" to 18" below the bottom of the pervious pavement system, 80% of the pervious pedestrian walk and bike path areas can be subtracted from the total contributing area when computing the project's required treatment volume.
  - For soils with SHGWT depths greater than 18" below the bottom of the pervious pavement system, 100% of the pervious pedestrian walk and bike path areas can be subtracted from the total contributing area when computing the project's required treatment volume.
20. To receive this credit, pervious walks and bicycle paths must be placed over native upland soils (excluding wetlands), appropriate clean fill, or soil media described in [Section 5.16](#). For redevelopment projects, the pervious walks and paths must be placed over rehabilitated soils as described in 7 above.
21. For non-vehicular pervious pavements that are properly designed, constructed, and maintained pursuant to this Section, vacuum sweeping, remediation plans and ongoing O&M re-inspections and certifications will not (normally) be required.



### 5.9.6. Required Site Information

Successful design of a pervious pavement system depends heavily upon conditions at the site, especially information about the soil, geology, and water table conditions. Specific data and analyses required for the design of a pervious pavement system are set forth in [Appendix C](#) of this Manual.

### 5.9.7. Construction requirements

The following construction procedures are required to assure that the pervious pavement is properly prepared and installed such that the desired infiltration rate is obtained:

1. The location and dimensions of the pervious pavement shall be verified on-site prior to its construction. All design requirements including pervious pavement dimensions and distances to foundations, septic systems, and wells need to be verified.
2. The location of pervious pavement areas shall be clearly marked at the site to prevent unnecessary vehicular traffic across the area causing soil compaction.
3. Excavation shall be done by lightweight equipment to minimize soil compaction. Tracked, cleated equipment does less soil compaction than equipment with tires.
4. Once the subgrade elevation has been reached, the area shall be inspected for materials that could puncture or tear the filter fabric, such as tree roots, and assure they are not present.
5. The in-situ (or imported) subgrade soil (below the pervious pavement system) shall be compacted to a maximum of 92% - 95% Modified Proctor density (ASTM D-1557) to a minimum depth of 24 inches.
6. The specified filter fabric shall be installed in accordance with the design specifications.
7. The aggregate material shall be inspected prior to placement to ensure it meets size specifications and is washed to minimize fines and debris. It should be spread uniformly to the appropriate thickness.
8. The pervious pavement material shall be installed by a contractor, trained and certified by the product manufacturer, to install the proposed pervious pavement system according to approved design specifications. When pervious pavements are being used, the mix shall be tested to assure it meets specifications before it is accepted and poured.
9. Stormwater shall not be directed onto the pervious pavement from adjacent contributing areas until after they are stabilized to prevent sediment from entering and clogging the pervious pavement.
10. Before the pervious pavement is placed into operation, signs shall be installed at all entrances advising users that they are entering a pervious pavement parking lot and that vehicles with heavy wheel loads or muddy tires should not enter.
11. An applicant may propose alternative construction procedures to assure that the design infiltration rate of the pervious pavements is met.

### 5.9.8. Inspection, Operation and Maintenance

Maintenance issues associated with pervious pavements are related to clogging of the porous surfaces which reduces or prevents infiltration thereby slowing recovery of the stormwater treatment volume and often resulting in standing water and the designed nuisance flooding.

To determine if the pervious pavement is properly functioning or whether it needs maintenance requires that either an inspection be within 72 hours of a storm and that the ERIK devices be used to test the infiltration rate as specified below.

### 1. Inspection Items:

- Inspect pervious pavement for storage volume recovery within the permitted time, generally less than 72 hours. Determine if nuisance flooding is occurring in those areas of the parking lot that were designed to flood if the pervious pavement was failing. Nuisance flooding indicates that the required treatment volume is not infiltrating because of a reduction of the infiltration rate and a need to restore system permeability
- Use the ERIK infiltrometers at least once every two (2) years to test if the vertical hydraulic conductivity is less than 2.0 inches per hour or is less than the permitted design percolation rate in any of the required ERIK infiltrometers. If any of the ERIK infiltrometers have rates less than the permitted rate, maintenance activities shall be undertaken to restore the permeability of the pervious pavement. The results of the ERIK infiltrometer testing shall be submitted to the County.
- Inspect all edge constraints and overflow areas to determine if any erosion is occurring and repair as needed.

### 2. Maintenance Activities As-Needed To Prolong Service:

- Vacuum sweeping will be conducted annually and whenever the vertical hydraulic conductivity is less than 2.0 inches per hour or is less than the permitted design percolation rate in any of the required ERIK infiltrometers. Vacuum sweeping will be done on an as-needed basis on pervious pavements located in areas that are subject to wind transported soils (near sand dunes or other coastal areas) or other conditions where excessive soil or other debris deposition is expected to occur (from adjacent landscaping mulch and leaf litter, from areas with high leaf fall, fugitive sands and lime rock fines from adjacent construction sites, etc.).
- A remediation plan shall be submitted to the County should vacuum sweeping fail to improve the vertical hydraulic conductivity to a rate greater than 2.0 inches per hour, or equal to or greater than the permitted design percolation rate, or resolve the nuisance ponding. The remediation plan shall be prepared and submitted to the County for review and approval.
- Repair erosion near edge constraints or overflows and assure that the contributing drainage area is stabilized and not a source of sediments.

Figure 5.9.2. Pervious Pavement System Cross Section #1

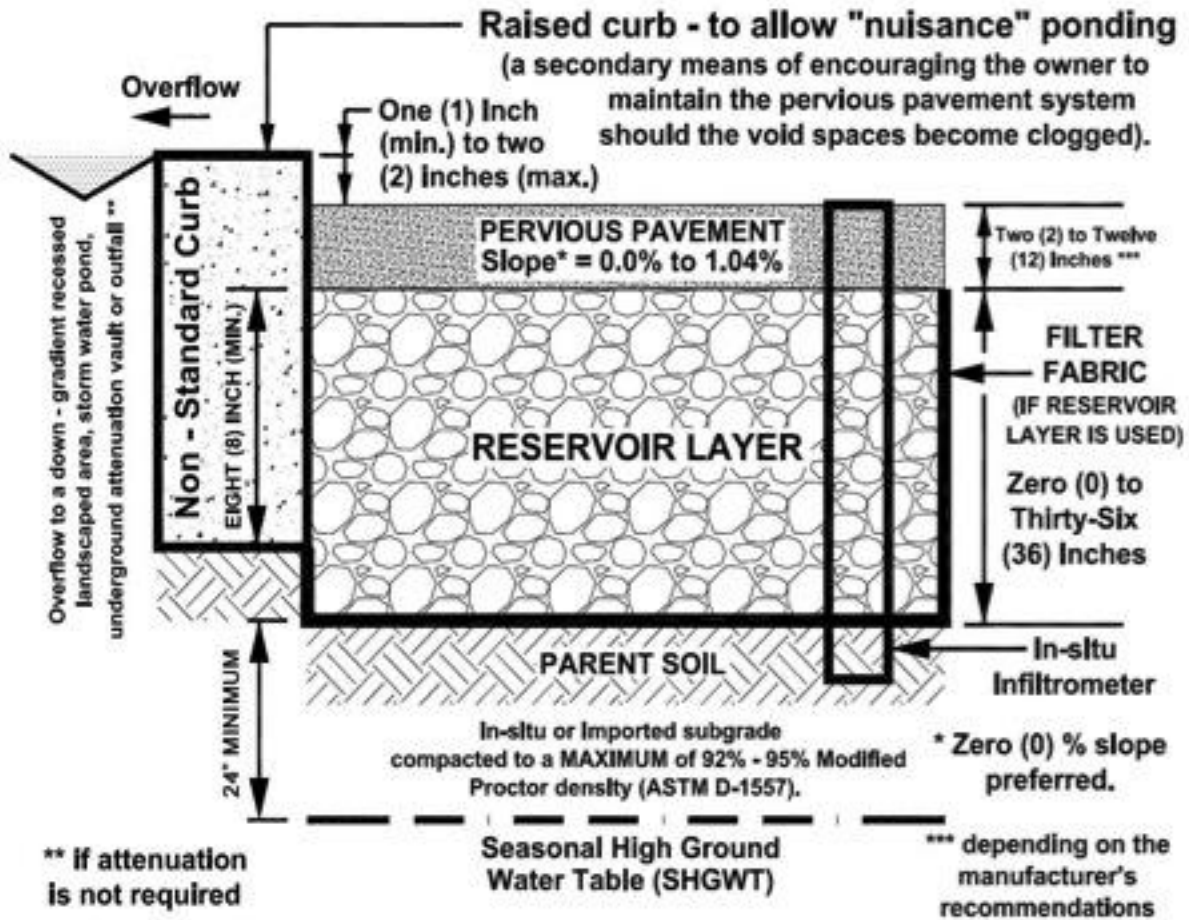

**Potential Pervious Pavement Cross Section #1**  
Scale: None

Figure 5.9.3. Pervious Pavement System Cross Section #2

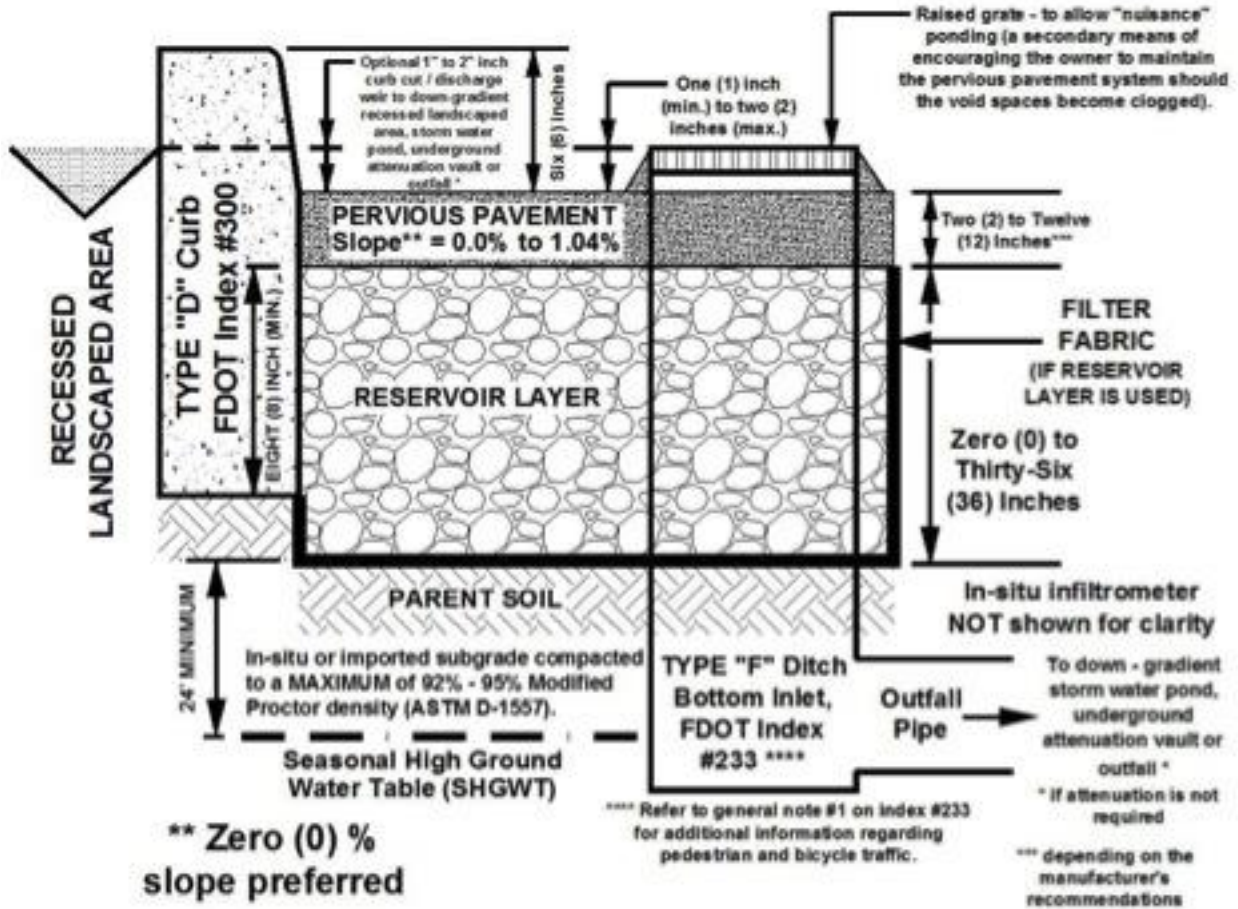

Potential Pervious Pavement Cross Section #2  
Scale: None



Figure 5.9.4. Typical Pervious Pavement System Cross Section #3

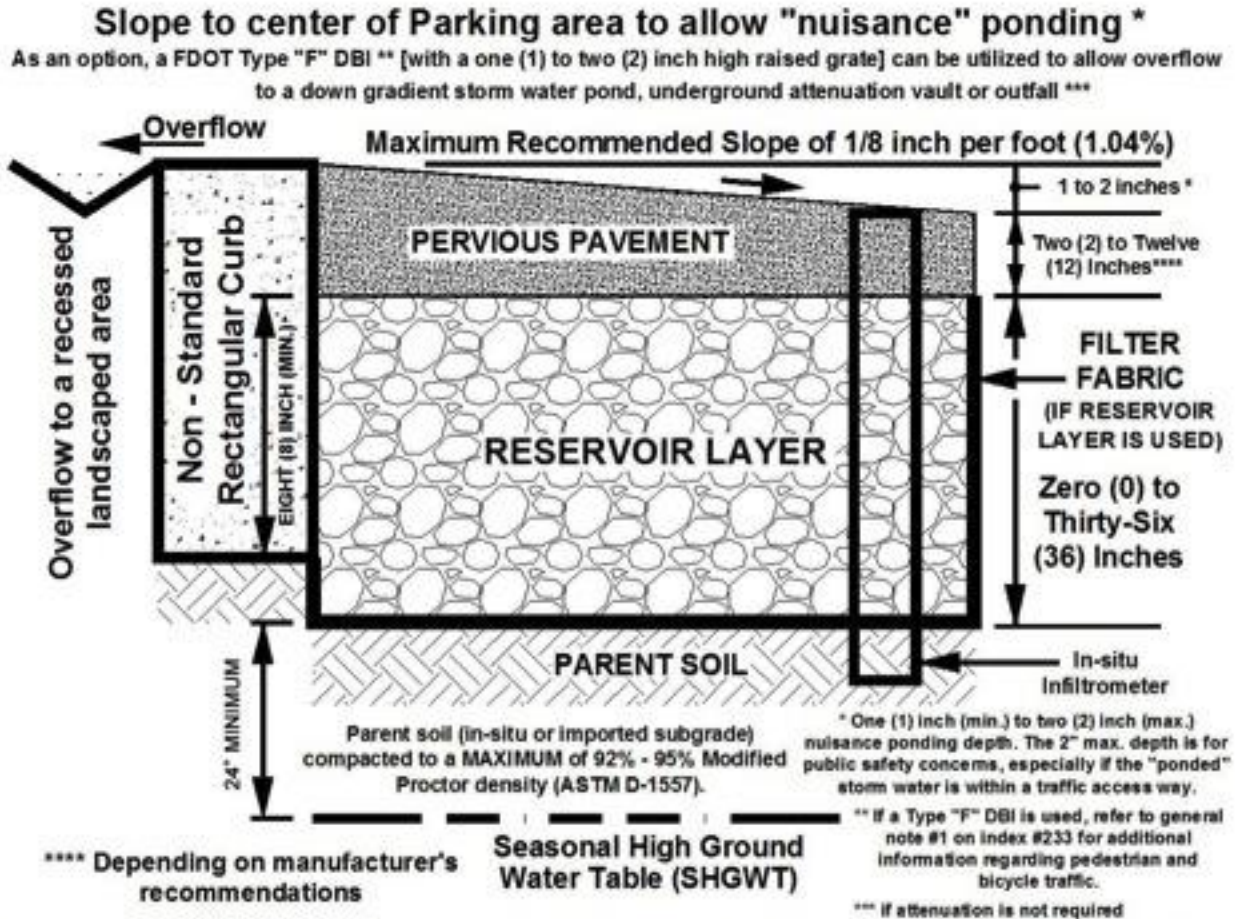

**Potential Pervious Pavement Cross Section #3**  
Scale: None



Figure 5.9.5. Plan View of ERIK In-Situ Infiltrometer - (Embedded Ring Infiltration Kit)

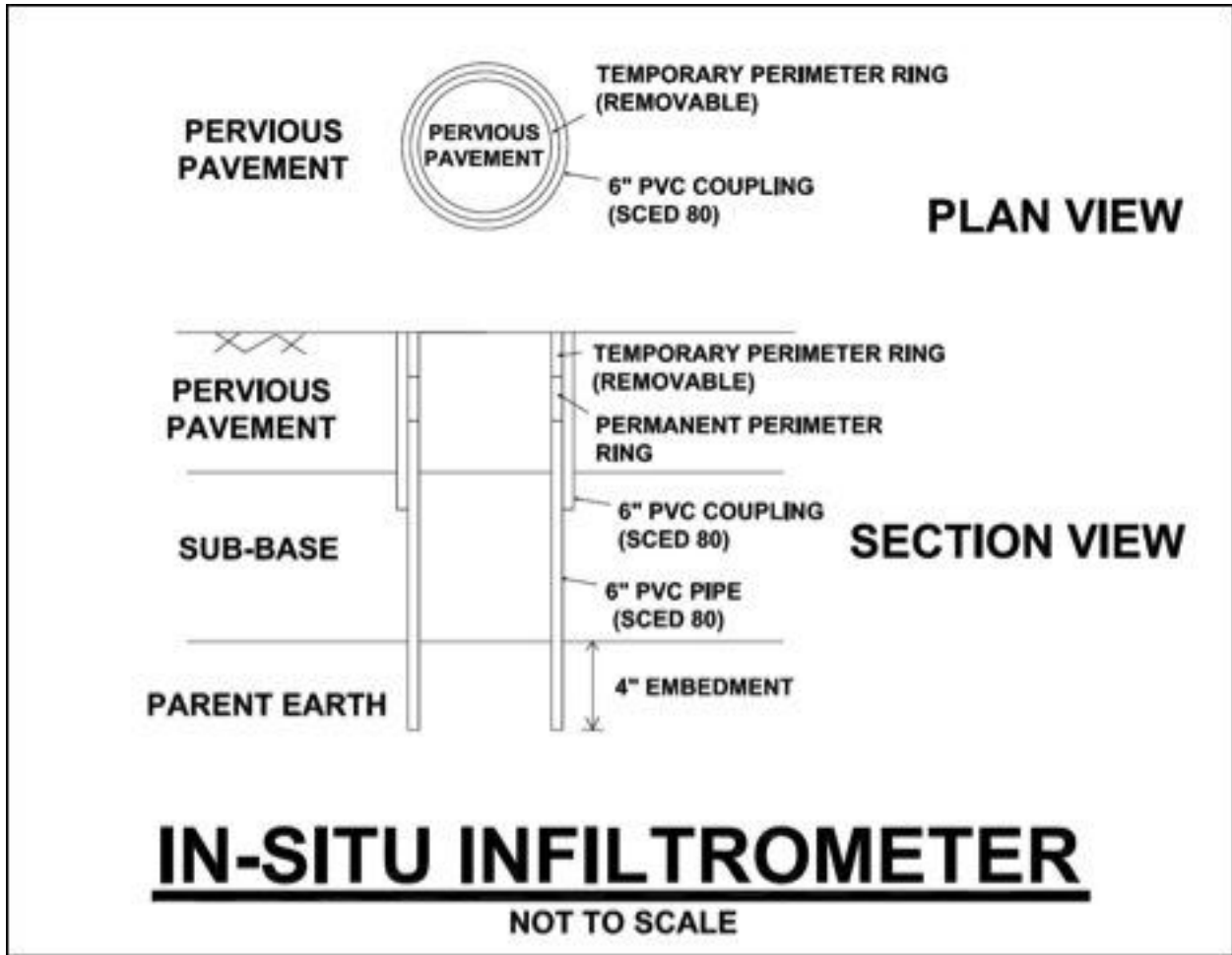

Figure 5.9.6. ERIK Measuring Tube

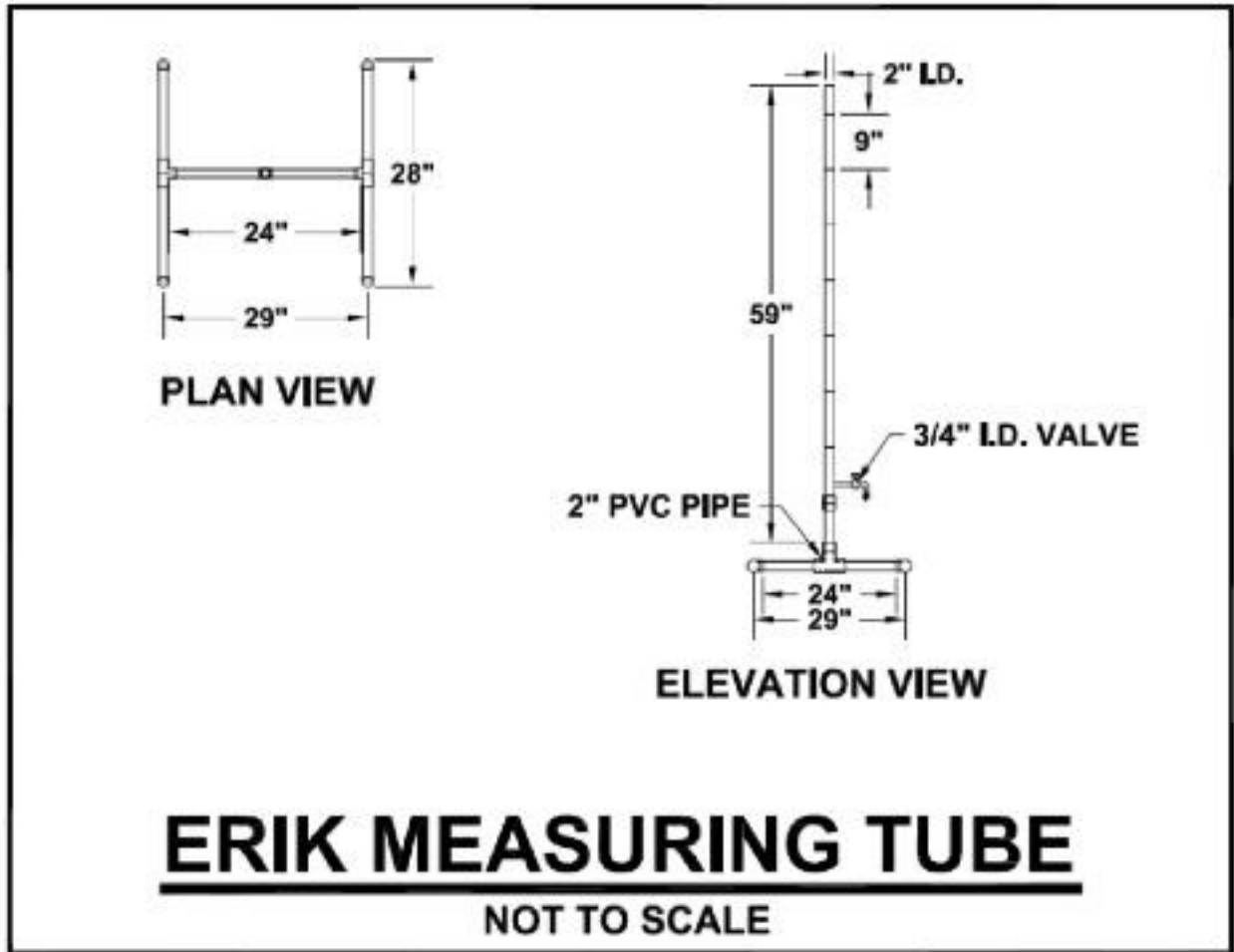

Figure 5.9.7. Pervious Pavement Site Plan

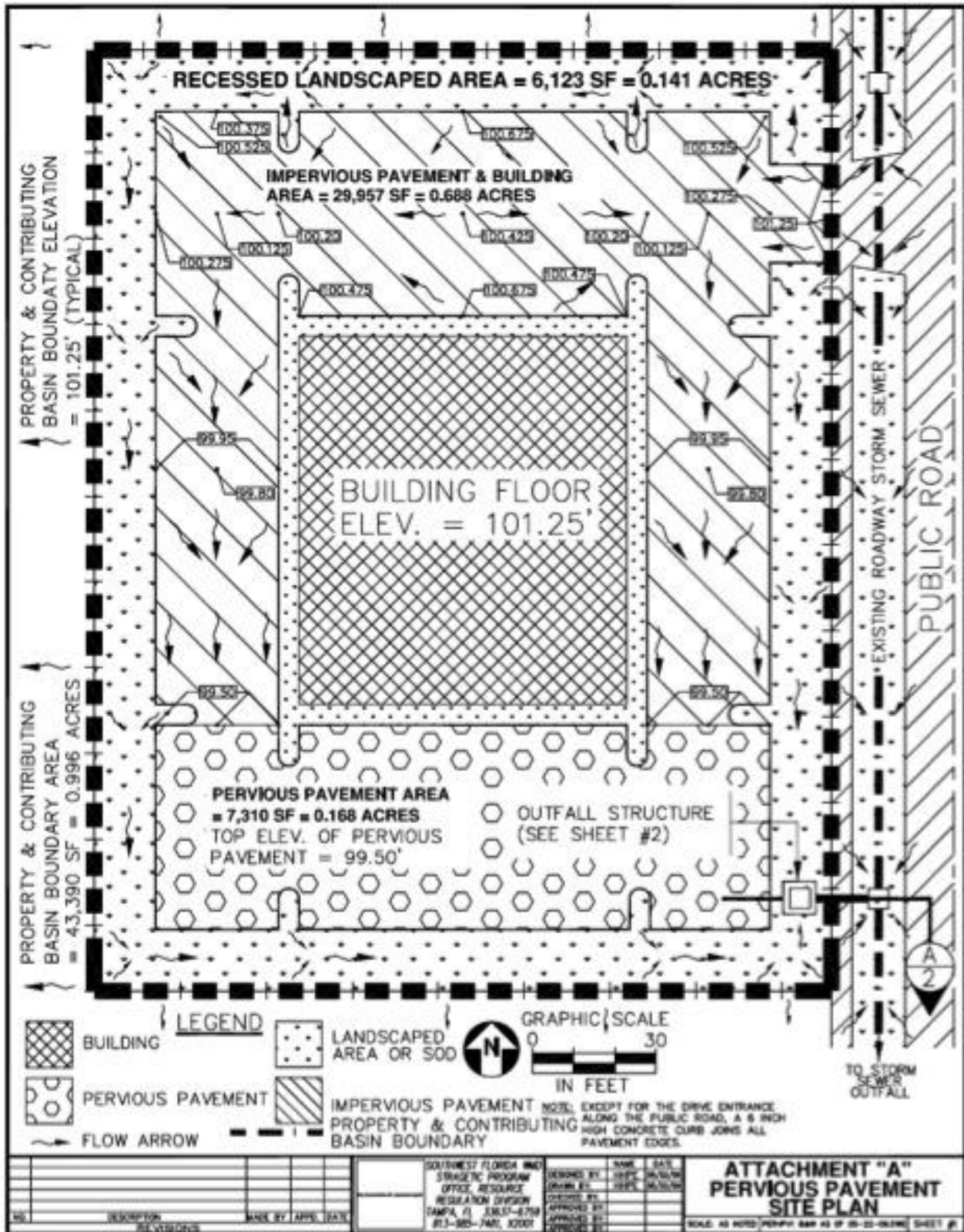



Figure 5.9.8. Pervious Pavement Site Plan

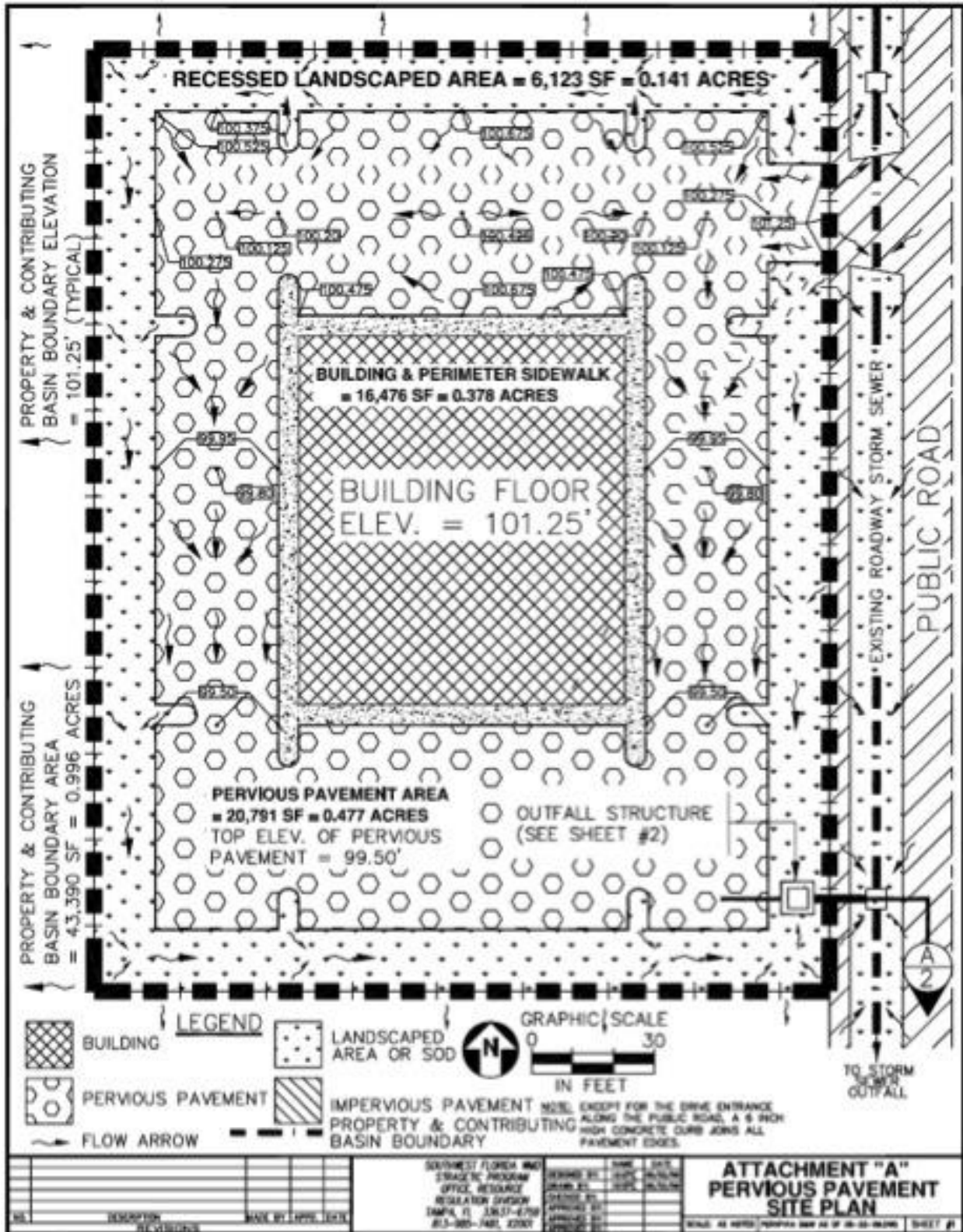
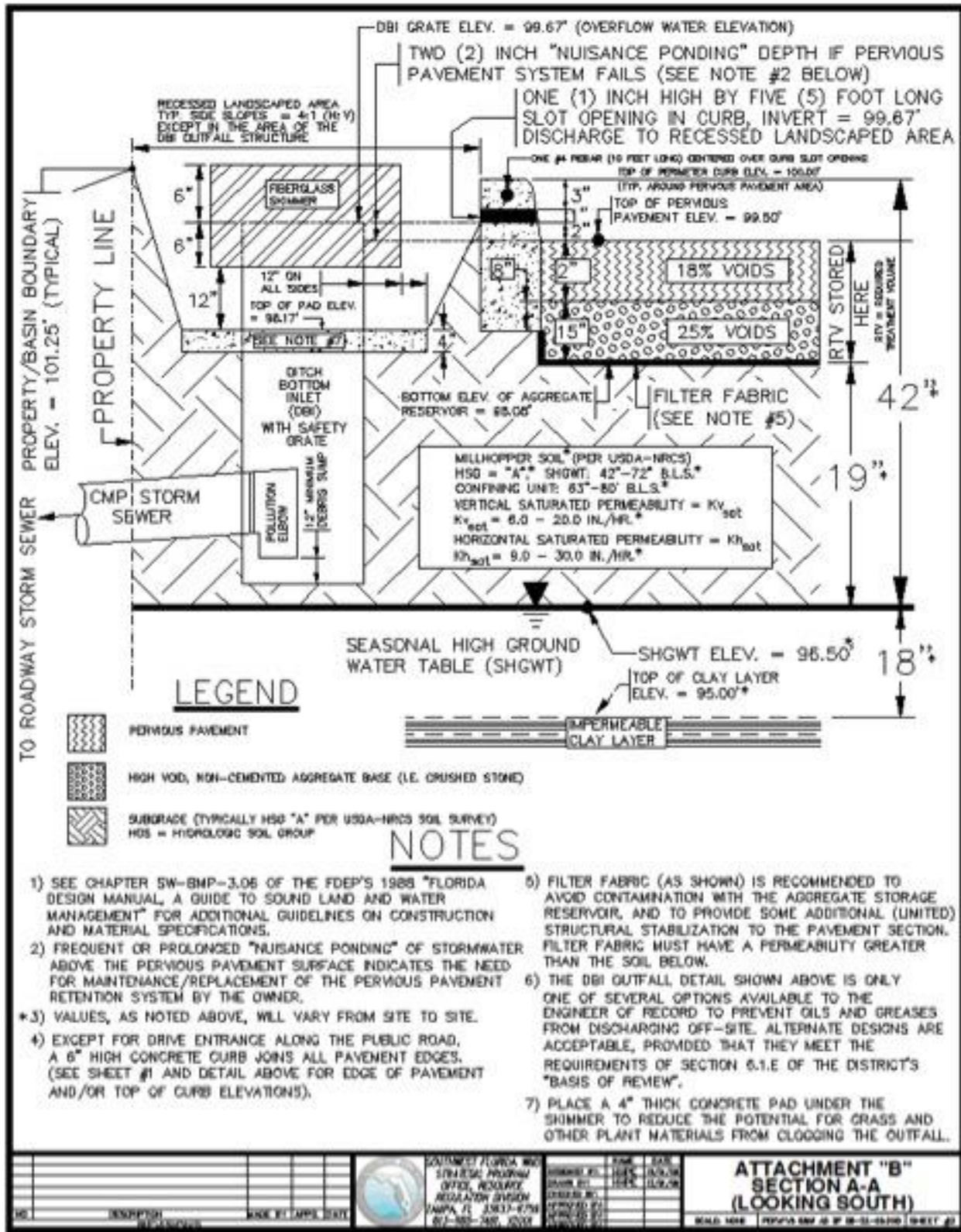

Figure 5.9.9. Pervious Pavement Site Plan





## 5.10. Greenroof with Cistern Systems

### 5.10.1. Description

A greenroof with cistern stormwater treatment system is a vegetated roof followed by storage in a cistern (or other similar device) for the filtrate that is reused for irrigation. [Section 5.10.4](#) describes the two classes of greenroofs: intensive and extensive. A greenroof and cistern system is a retention and reuse BMP. Its effectiveness is directly related to the annual volume of roof runoff that is captured, retained, and reused. The filtrate from the greenroof is collected in a cistern or, if the greenroof is part of a BMP Treatment Train, the filtrate may be discharged to a downstream BMP such as a wet detention pond. A cistern is sized for a specific amount of filtrate and receives no other stormwater. Other pond storage must also provide capacity to detain a specified quantity of filtrate.

The retained water is used to irrigate the roof since experience in Florida has shown that irrigation must be provided to maintain the plants. A back up source of water for irrigation is necessary during the dry season. Excess filtrate and excess runoff can be discharged into other stormwater treatment systems, infiltrated into the ground, or used for irrigation or other non-potable purposes. The greenroof and cistern system functions to attenuate, evaporate, and lower the volume of discharge and pollutant load coming from the roof surface. Greenroof systems have been shown to assist in stormwater management by attenuating hydrographs, neutralizing acid rain, reducing volume of discharge, and reducing the annual mass of pollutants discharged. They are most applicable to commercial or public buildings, but have been successfully used on residences.

Concentrations of pollutants discharged from a greenroof with pollution control media have been shown to be approximately the same as would be anticipated from a conventional roof. Thus, the concentration and mass must be managed. If no pollution control media are used, greenroof concentrations are greater than those from conventional roofs. In addition, with fertilization of the plants, increased nutrients are expected and storage for the filtrate is required.

### GREENROOF/CISTERN SUMMARY

<p>Advantages/Benefits</p>	<p>Reduces site imperviousness, stormwater volume, peak discharge rate, pollutant loadings, temperature, and heat island effect. Increases insulation of roof reducing energy use for heating and cooling. A six inch extensive roof provides insulation equivalent to about R-7 with energy cost savings of 10-15%. Increases efficiency of solar cells. Increases life of roof to over 50 years. Can be an aesthetic amenity or an area for gardening. Provides ground water recharge and water reuse. Increases development potential of site.</p>
<p>Disadvantages/Limitations</p>	<p>More expensive than traditional roofs and more difficult to install. Typically used on flat roofs. Must meet roof structural integrity and have handicap access.</p>
<p>Volume Reduction Potential</p>	<p>Moderate to High depending on roof area and storage volume</p>

<p>Pollutant Removal Potential</p>	<p>Moderate to High for all pollutants depending on annual average retention volume and whether <a href="#">BAM</a> is used in the media.</p>
<p>Key design considerations</p>	<p>Must be located on building roof. Treatment system includes waterproofing layer, root barrier layer, drainage layer, pollution control layer, filter fabric, growth media layer and vegetation with irrigation and storage for greenroof filtrate. Must have source of backup water supply. Must have minimum 2"/hr infiltration rate through the entire system. recovery of treatment volume within 24 – 72 hours;</p>
<p>Key construction and maintenance considerations</p>	<p>Minimize soil compaction and sedimentation during construction; ensure design infiltration is met after construction; inspect during wet season to see if water is ponding and not infiltrating properly; use regular vacuum sweeping to minimize clogging and maintain infiltration capacity as needed to meet permit requirements; must maintain at least 2"/hr percolation rate; areas with high levels of wind-blown sediments (e.g., near the beach) may create maintenance issues.</p>

**5.10.2. Required Treatment Volume**

The treatment volume necessary to achieve the required treatment efficiency shall be captured by the greenroof and cistern system then used for irrigation of the greenroof plants or other landscaping. The required nutrient load reduction will be determined by the type of water body to which the stormwater system discharges and the associated performance standard as set forth in [Section 4.3](#) of this Manual.

Like all retention BMPs, the nutrient removal effectiveness is directly related to the annual volume of roof runoff that is retained and for greenroofs that is the volume stored within the greenroof and cistern system. However, since supplemental water inputs are needed for irrigation, some of which returns to the cistern, the cistern must be sized larger than the retention treatment volume. Nevertheless, the method can be used for nutrient load reduction.

Treatment volumes to achieve the required load reduction efficiencies shall be determined based on the percentage of DCIA and the weighted Curve Number for non-DCIA areas as set forth in Table B1-1 and B2-1. Table B1-1 provides dry retention depths (inches of runoff over the drainage area) to achieve 80 percent removals for the Zone 2 meteorological regions.

**5.10.3. Calculating Load Reduction Efficiency for a Given Retention Volume**

Use [Table B1-1](#) to determine the treatment volume needed to achieve an 80% pollutant load reduction if greenroof/cistern systems are being used to fully achieve the required level of pollutant load reduction.

If greenroof with cistern systems are being used as part of a BMP treatment train to achieve some level of pollutant load reduction but not the total amount of the required nutrient load reduction, use [Table B2-1](#).

As an alternative, the design curves in [Section 5.10.9](#) can be used to determine the treatment volume.

**5.10.4. Classification of Greenroof Surfaces**

Green roofs are classified in two ways - both by who will have access to the finished roof (either passive or active) and by the depth of soil provided in the plant root zone (either extensive or intensive). Extensive green roofs tend to have passive use, while intensive green roofs support larger plants and tend to have active use. Passive green roofs only allow access by maintenance personnel. Active green roofs allow access to the public or building occupants in addition to maintenance personnel. In addition, extensive green roofs have a root zone less than 6 inches deep while intensive green roofs have a root zone equal to or greater than 6 inches deep.

**Figure 5.10.1a. Extensive Greenroof Section (Usually Passive Function)**

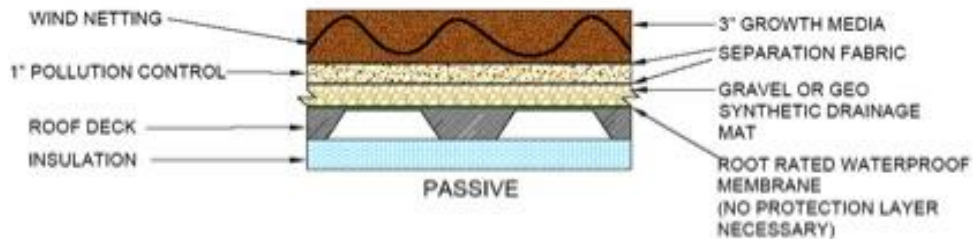

The root zone is comprised of the growth media and the pollution control media. A permeable fabric is used on both sides of the pollution control media to separate it from the soil or growth media layer above and a drainage layer below. A membrane, impervious to water and plant roots, is placed under the drainage layer to isolate the green roof system from the structural members of the building.

Greenroofs can be built on any type of roof deck with a minimum slope of one inch per foot if adequate structural support is provided. Extensive roofs weigh approximately 10 – 35 lbs./ft<sup>2</sup> when wet while intensive roofs weigh approximately 45-100 lbs./ft<sup>2</sup> when wet. Accordingly, as part of the application, a structural engineer must certify that the roof can safely handle the weight load of the greenroof. There are several components that are required for greenroofs as described in the following sections of this Manual. Figures 5.10.1a and 5.10.1b provide typical greenroof details for the different types of roofs and various component details.

**Figure 5.10.1b. Intensive Greenroof Section (Usually Active Function)**

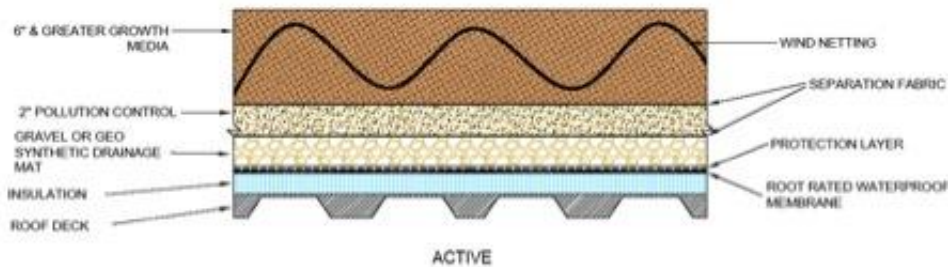

### 5.10.5. Design Criteria

1. **Minimum Retention** -Greenroof with cistern systems shall be designed to capture and use the required treatment volume for irrigation without discharge except to downstream BMPs if used as part of a BMP treatment train.
2. **Structural Integrity** – A structural engineer must certify that the roof can support the weight load of the greenroof system. Design must comply with [the American National Standards Institute \(ANSI\) VF-1, Fire Design Standard for Vegetative Roofs](#).
3. **Waterproof Membrane** - A waterproof membrane layer must be incorporated into the roof system to protect the structure from moisture damage. There are several options for this layer such as, polypropylene or polyethylene membrane, polyvinyl chloride, or spray applied elastomeric waterproofing membrane as well as others. The applicant must check with the membrane manufacturer to ensure that the membrane is rated as a *root protection material*. All permitted design specifications and manufacturer’s installation directions shall be followed to ensure that the proposed product will function as intended with greenroof overburden.
4. **Drainage Layer** - The major function of the drainage layer is to facilitate lateral movement of the filtrate to the point of drainage to ensure no standing water is present. The drainage layer can consist of several different materials such as gravel, recycled products, or geosynthetic drainage mats. It is important to note that whatever material used shall not depress or elevate the pH of the filtrate more than 1.5 pH units from neutral (5.5 to 8.5). When using aggregate as drainage layer materials, it must contain no more than 7% “fines” (particles passing sieve number 200) by mass. The drainage material must be able to structurally support the intended greenroof overburden, as well as maintenance activities, without deflection such that drainage is blocked or restricted. A non-woven geotextile separation fabric must be installed on top of the drainage layer to prevent clogging of the drainage layer. This fabric shall have a thickness to pass the drainage water and void spaces such that the pollution control media does not fill the surface void area of the drainage layer and cause clogging. The hydraulic conductivity of the fabric must exceed 1.5 inches per hour.
5. **Pollution Control Media** - Greenroofs used for stormwater treatment credit must use a pollution control media layer. The pollution control layer is at least 1 inch in depth. This layer is to include materials known to adsorb pollutants such as phosphorus, nitrogen, metals or other pollutants of concern for the installation site. Pollution control media shall meet the following specifications.
  - All soil media mixes must display no acute toxicity at the applied media mix.
  - Unit Weight is no more than 45 pounds per cubic foot when dry.
  - No more than 5% of the particles passing the #200 sieve.
  - Over 50% mineral by volume and contains no shale.
  - At least 1 inch in thickness.
  - Water holding capacity is at least 30%, and as measured by porosity.
  - Permeability is at least 1.5 inches per hour. Permeability is vertical hydraulic conductivity at the specified unit weight noted above.
  - Organic content is no more than 10% by volume.
  - pH is between 6.5 and 8.0.
  - Soluble salts are less than 3.5 g (KCL)/L.
  - Sorption capacity exceeds 0.005 mg OP/mg media.

**6. Growth Media** - The growth media is intended to be the main support coarse for the vegetation. The growth media is installed on top of the separation fabric. Growth media shall meet the following specifications.

- Unit Weight is no more than 45 pounds per cubic foot when dry.
- No more than 10% of the particles passing the #200 sieve.
- Contains no shale.
- At least 3 inches in thickness.
- Water holding capacity is at least 30%, and as measured by porosity.
- Permeability is at least 1.5 inches per hour. Permeability is vertical hydraulic conductivity at the specified unit weight noted above.
- Organic content is no more than 10% by volume.
- pH is between 6.5 and 8.0.
- Soluble salts are less than 3.5 g (KCL)/L.

**7. Preventing wind uplift** – To assure that a greenroof built in Florida remains operable, the greenroof must be designed to prevent wind uplift. A three-dimensional netting made of polyamide (nylon) filaments connected together woven into the growth media layer or other equivalent method is acceptable. As an alternative, a parapet of sufficient height can be used. For buildings less than 100 feet tall, a parapet height of 36 inches can be used in place of wind netting.

**8. Vegetation** – [Florida-friendly](#) or native vegetation is recommended on greenroofs used for stormwater treatment. Low maintenance plants and drought tolerant plants are recommended but not mandatory because of the use of stored stormwater for irrigation. However, plants tolerant to high levels of direct sunlight and high temperatures are necessary for the success of a healthy greenroof plants. Care should be made to ensure that the available root zone of the greenroof is sufficient for the intended plants. When designing an intensive greenroof, larger plants with more rigorous maintenance schedules are acceptable. Plants must achieve at least 80% cover of the greenroof area within one year of planting. When the vegetation density is less than 80%, new plants shall be added. Table 5.10.1 includes plants that have been successfully used on greenroofs in the different parts of Florida. Other plants are acceptable and applicants are encouraged to consult landscape architects and native nursery personnel for appropriate plants. Note for plants used on greenroofs in coastal areas, salt tolerance is an important consideration. Some examples of plants used along the coast are Simpson stopper, Snake plant, Muhly grass, Inkberry, and Beach sunflower.

**Table 5.10.1. Plants that have been successfully used on greenroofs in Florida**

<i>PLANT</i>	<i>NORTH FL</i>	<i>CENTRAL FL</i>	<i>SOUTH FL</i>
<b>Muhly grass</b>	X	X	X
<b>Butterfly Weed</b>		X	X
<b>Blanket Flower</b>	X	X	X
<b>Sunshine mimosa</b>		X	X
<b>Perennial peanut</b>	X	X	X
<b>Snake weed</b>		X	X
<b>Asiatic Jasmine</b>	X	X	X



<i>PLANT</i>	<i>NORTH FL</i>	<i>CENTRAL FL</i>	<i>SOUTH FL</i>
<b>Simpson Stopper</b>		X	
<b>Black Eyed Susan</b>	X	X	
<b>Beach Sunflower</b>	X	X	X

9. **Irrigation** - Irrigation is required on all greenroofs in Florida to assure plant survival and to recover the required treatment volume. A rain sensor is required to monitor rainfall and the need for irrigation. Drip irrigation applied at the growth media surface is required, usually with one foot on-center spacing. Irrigation pumps must be installed with an alarm system to signal any mechanical problems. Irrigation will vary by season and a rain shut-off sensor is required. Flow meters shall be installed as a means of documenting when irrigation occurs and the volume of water used for irrigation. The addition of make-up water will be required during parts of the year depending on local rainfall patterns and records must be kept to document how much make-up water is added. The recommended source of make-up water is stormwater or gray water, whenever available. An in-line filter is recommended to reduce the maintenance problems and cost of irrigation line replacement. Depending upon the greenroof retention volume and design, irrigation shall occur three to four times per week with a maximum total application of one (1.0) inch per week if filtrate or stormwater are available.
10. **Roof Drain** - The greenroof must drain into a storage device, typically a cistern. The slope of the roof must be at least ¼ inch per foot. The primary drain can be an interior drain or gutter drain. A one foot barrier must be maintained around the drain to prevent vegetation and debris from clogging drain as well as providing easy inspection. This barrier can be an aluminum break or a washed river stone section. An overflow shall also be provided to ensure drainage in case a clog occurs in the primary drain.
11. **Cistern or Other Water Storage Area** - The cistern or other water storage area serves to store filtrate for use as irrigation. Filtrate volumes greater than those required for irrigating the greenroof can be used to either irrigate ground level landscaping or can be directed to other retention BMPs that allow for infiltration. If there is a discharge to a wet detention system, then the greenroof efficiency must be calculated using the BMP Treatment Train equations. Cistern or other storage placement can be below ground or above ground. If an above ground cistern is used it must be UV stable, dark in color, and must be placed in areas of low to no direct sunlight. Direct sunlight may cause irrigation water temperature to get too hot for plants.

**5.10.6. Design Criteria for Management of the Filtrate**

There are two common designs for management of the filtrate. The first design is to collect filtrate from a greenroof in a cistern. The cistern has no other water inputs except for supplemental makeup water. It is also not open to the atmosphere. Water in the cistern is used to irrigate the greenroof, or other nearby landscaping, or can be used for other non-potable purposes. Cistern annual volume reduction equations and graphs as a function of cistern storage were developed and are used to estimate retention as a function of the storage volume. For this design management of filtrate, the yearly mass reduction is equal to the yearly volume reduction. Cistern design curves are provided in [Section 5.10.9](#) of this Manual for greenroofs and for irrigation rates commonly used in Florida. The design curves provide the amount of cistern storage required for a specified annual retention of rainfall or reduction in discharge from the greenroof and cistern system.

The second design condition is when the greenroof filtrate is discharged from the roof into a conveyance system or into another BMP such as a wet detention pond. For this case, the removal of the nutrient is proportional to the removal effectiveness of the pond. However, note that the flow to the pond without a cistern is reduced by 44%.

#### **5.10.7. Construction requirements**

To assure proper construction of the greenroof/cistern system the following construction procedures are required:

1. Construct the greenroof in accordance with permitted design plans and specifications.
2. Be sure that all greenroof waterproofing components are properly installed before placing any of the media on the greenroof.
3. Be sure all equipment and plants are properly sited per design drawings and installed properly.
4. Construct the irrigation system in accordance with all permitted design specifications and irrigation system design standards.
5. Assure that all irrigation components are properly sited and that irrigation spray heads are working properly and not spraying irrigation water onto impervious areas.

#### **5.10.8. Inspections, Operation and Maintenance**

Maintenance issues associated with greenroof with cistern systems are related to the health of the plants, the drainage capabilities of the system, and proper functioning of the irrigation system.

Greenroof with cistern systems must be inspected annually by the operation and maintenance entity to determine if it is operating as designed and permitted. Reports documenting the results of annual inspections shall be filed with the County every three years.

##### 1. Inspection Items:

- Inspect operation of the greenroof/cistern system to assure that rainfall is flowing properly through the greenroof and into the cistern.
- Inspect the plants on the greenroof to assure they are healthy and growing. Assure plants are covering at least 80% of the surface area of the greenroof and that plant species not on the approved plant list are not becoming established.
- If an intensive greenroof, inspect it for damage by foot traffic or other human uses of the greenroof.
- Inspect the operation of the pumping system and the irrigation system to assure they are working properly.

##### 2. Maintenance Activities As-Needed To Prolong Service:

- Repair any components of the greenroof drainage system which are not functioning properly and restore proper flow of stormwater or filtrate.
- Maintain the plants on the greenroof on an as needed basis to assure healthy growth and meet the required 80% coverage of the greenroof. Weeding to remove plants not on the approved design plant list will be needed on a regular basis. Whenever plant coverage is less than 80%, new plants shall be established as soon as possible.
- Repair any damage to the greenroof by foot traffic or other human uses.
- Repair or replace any damaged components of the pumping and irrigation system as needed for proper operation.

### 3. Record keeping

The owner/operator of a greenroof/cistern system must keep a maintenance log of activities that is available at any time for inspection or recertification purposes. The log will include records related to the use of the filtrate water for irrigation to demonstrate that the permitted nutrient load reduction is being achieved. A flow meter to measure the quantity and day/time of irrigation is required. Visual observations of the success of plant growth and cover, including photo documentation is also required. The maintenance log shall include the following:

- Irrigation volume measured using a flow meter specifying the day and amount;
- Cistern overflow volumes and makeup water volumes;
- Observations of the irrigation system operation, maintenance, and a list of parts that were replaced;
- Pruning and weeding times and dates to maintain plant health and 80% coverage;
- A list of dead, dying, or damaged plants that are removed and replaced;
- Maintenance of roof mechanical equipment;
- Dates on which the greenroof was inspected and maintenance activities conducted; and
- Dates on which fertilizer, pesticide, or compost was added and the amounts used.

#### 5.10.9. Greenroof with Cistern - Harvesting Design Curves and Equations

A cistern or similar storage device is used with a greenroof to store the water and then the stored water is reused on the greenroof for irrigation. By doing this, the direct discharge to surface water is reduced. [Wanielista and Hardin \(2006\)](#) showed that a cistern designed to collect 5 inches of rainfall from a greenroof with pollution control media composed of a blend of tire crumb, is able to remove at least 90% of the mass of Soluble Reactive Phosphorus (SRP) and 98% of the mass of Nitrate Nitrogen. These removals were measured over one year and depend on the rainfall conditions in that year. The size of the cistern is dependent on local rainfall conditions and the rate of water used from the cistern.

The greenroof and cistern functions to attenuate, evaporate, and lower the volume of discharge coming from a roof surface. The greenroof system will also neutralize acid rain, reduce mass of pollutants, and attenuate hydrographs. The storage discharge design of the cistern determines the attenuation. A greenroof with cistern will achieve higher stormwater volume and load reductions (greater than 70%) than if used without a cistern (~ 40%). When used with a cistern, the cistern discharge will have less pollutant mass than discharge without a cistern. Design graphs have been developed for many locations in the State (Hardin, 2006 and Hardin and Wanielista, 2007). The greenroof with cistern harvesting design curves and equations for Alachua County (based on Gainesville) are shown below:

**Figure 5.10.2. Greenroof Harvesting Design Curve for Gainesville, Florida Area**  
 (Based on 1" irrigation/week using 32 years of data)

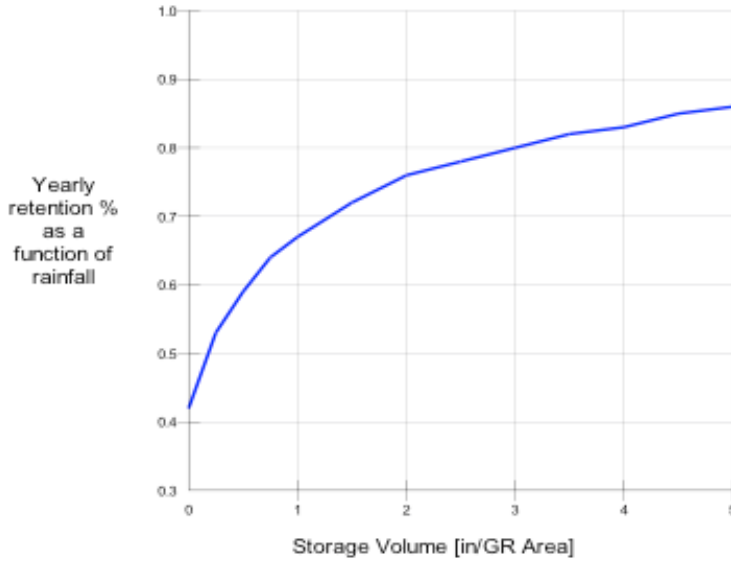

**Figure 5.10.3. Greenroof with Cistern Harvesting Equation for Gainesville, Florida Area**

(Based on 1" irrigation/week using 32 years of data)

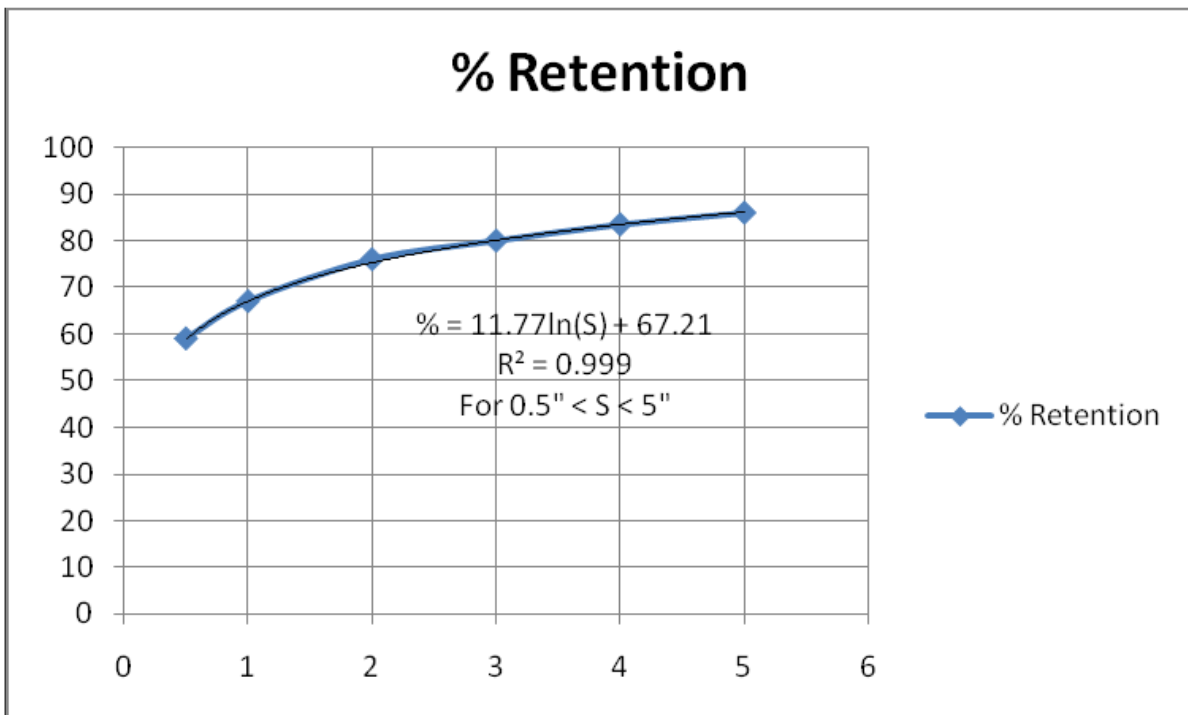

The design curves and equations are based on cistern storage values of between one-half inch (0.5") and five inches (5.0"). The upper storage limit of five inches was set because there is

marginal improvement in pollutant removal above five inches. For example, in Gainesville, the yearly retention of a greenroof with cistern system is:

% RETENTION =  $11.77 \ln(S) + 67.21$ . For example, if cistern storage is 2, this becomes:

$$\% \text{ RETENTION} = 11.77 \ln(2) + 67.21 = (11.77 * 0.69315) + 67.21 = 8.16 + 67.21 = 75.37\%$$

This is considerable larger than the 42% retention by the greenroof alone greatly increasing the average annual retention volume and pollutant load reduction.



## 5.11. Rainwater Harvesting

### 5.11.1. Description

The term “rainwater harvesting” most commonly refers to water collected from roofs that is stored and reused. Rain is a free source of relatively clean, soft water. As rain falls onto surfaces such as concrete, pavement, and grass it contacts more contaminants than it would from dry fallout on a roof. Harvesting rainwater from roof runoff is an easy, inexpensive way to disconnect impervious surfaces and capture water before it has contacted many potential contaminants. The purpose of capturing and reusing stormwater is to replace the use of potable water. Usually harvested rainwater is reused for outdoor irrigation, and the cost of using it in new developments has been estimated to be about 5-25% of the cost of potable water. Harvested rainwater can be used for a variety of uses ranging from outdoor irrigation and car washing to indoor uses including toilet flushing, clothes washing, irrigation of indoor planters, hose bibs, car washing, and potable use. However, most of these indoor uses require approval of the Alachua County Health Department and Planning Department.

Alachua County receives approximately 50 to 54 inches of rainfall per year. Based on this, a typical 2000 square foot roof can produce 62,000 to 73,000 gallons of water, adequate for residential grey water use and reasonable irrigation needs. The American Rainwater Catchment Systems Association (ARCSA) certifies professionals in design and construction of rainwater harvesting systems, and offers workshops at 3 levels of expertise. They have a web site at <http://www.arcsa.org/>

There are four types of rainwater harvesting systems:

- Small residential systems that store rainwater in rain barrels for supplemental irrigation.
- Large residential or commercial systems that store rainwater in a cistern for irrigation, vehicle washing, dust control, or other outdoor, non-potable uses.
- Large residential or commercial systems that store rainwater in a cistern as a source of indoor graywater uses such as toilet flushing, urinal flushing, Heating Ventilating and Air Conditioning (HVAC) make-up water, laundry wash water, and outdoor non-potable uses.
- Residential or commercial systems that store rainwater in a cistern for potable water.

### RAINWATER HARVESTING SUMMARY

Advantages/Benefits	Reduces site DCIA, stormwater volume, pollutant loadings; reduces potable water use and reuses rainwater for irrigation and other nonpotable purposes; provides ground water recharge and water reuse.
Disadvantages/Limitations	May require a pump, flow meter, and filtration system, depending on the determined uses of harvested rainwater.
Volume Reduction Potential	Moderate to High depending on roof area and storage volume

Pollutant Removal Potential	Moderate to High for all pollutants
Key design considerations	Only for managing roof runoff. Calculate roof area and annual stormwater volume; determine use for harvested rainwater (irrigation, graywater, potable); determine harvesting rate, volume, irrigation method, and equipment; obtain additional requirements for graywater or potable use from Alachua County Health Department; recovery of treatment volume within 24 – 72 hours;
Key construction and maintenance considerations	Ensure underground cisterns or storage vaults are protected against buoyant forces;

**1. Type 1. Non-potable Residential System with a Rain Barrel** - The first type of system is a small residential system that stores rainwater in rain barrels. These systems allow homeowners to retrofit their homes to reduce runoff and the amount of potable water consumed for irrigation. Many sources of information on designing and installing these systems are available on the internet:

- <https://www.scgov.net/AirAndWaterQuality/Pages/RainBarrel.aspx>
- <http://www.swfwmd.state.fl.us/conservation/rainbarrel/>
- <http://sarasota.ifas.ufl.edu/FYN/Rainbarrel.shtml>

Information and rain barrels also is available at home centers. Using rain barrels for rainwater harvesting is not an acceptable BMP for meeting ERP requirements. However, it is a good way for homeowners to reduce stormwater pollution and potable water use for irrigation.

**2. Type 2. Non-potable System for Outdoor Use with a Cistern** - The second type of system is a large commercial or residential system that uses a cistern or other permanent storage tank to store water for irrigation and/or other nonpotable uses. In these systems:

- Rainwater is collected by gutters and scuppers and routed through downspouts to a cistern.
- The downspouts are equipped with a device to divert the first flush of water away from the cistern and to screen out large material such as leaves.

- Cisterns typically are larger than 80 gallons and may provide aboveground or underground storage. If the cistern is underground, it must be constrained against buoyant forces.
- The irrigation system will likely require additional filtration and screening to prevent valves and spray heads from clogging.
- The harvested rainwater will require a pumping system to distribute the water. The components for this type of system are shown in the adjacent figure.

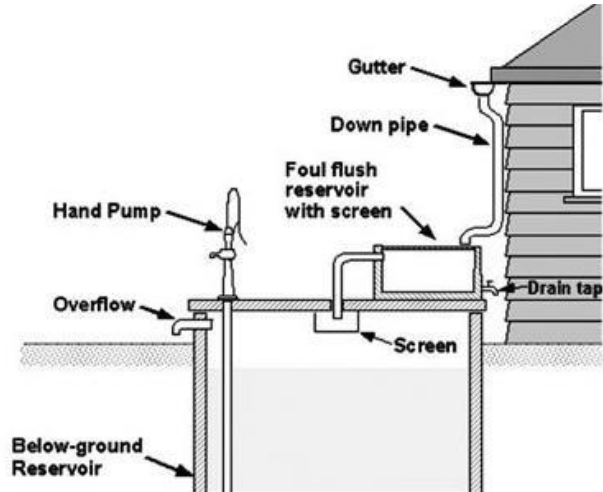

**3. Type 3. Non-potable System for Indoor and Outdoor Use with a Cistern** - The third type of system is a large residential or commercial system that stores rainwater and graywater in a cistern for indoor uses such as toilet flushing, urinal flushing, HVAC make-up water, laundry wash water, and other outdoor uses. In these systems:

- Rainwater is collected by gutters and scuppers and routed through downspouts to a cistern. Graywater is collected by internal plumbing and routed to the cistern.
- The downspouts are equipped with a device to divert the first flush of water away from the cistern and to screen out large material such as leaves.
- Cisterns are larger than 80 gallons and may provide aboveground or underground storage. If the cistern is underground, it must be constrained against buoyant forces.
- The harvested rainwater will require a pumping system to distribute the water.
- Indoor graywater (flushing and laundry) systems require disinfection, pre-filtering and fine filtering to between 5 and 20 microns.

This type of system has a potential for inadvertent human contact or consumption. Therefore, the system has additional requirements from the Alachua County Health and Building Departments. The components for this type of system are shown below.

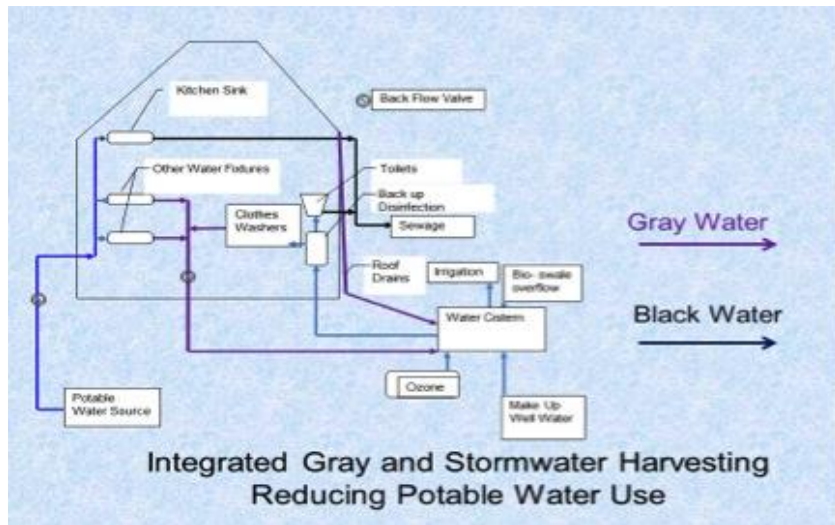

### 5.11.2. Applicability and Siting Considerations

A Rainwater Harvesting System is primarily designed to store and supply roof rainwater for use in lieu of high-quality potable water. They can be used on commercial, residential, and industrial areas. The cistern storage volume provides stormwater benefits along with non-potable water than can be used for numerous purposes. Due to the relatively small volume of roof runoff and the extreme variations in storm intensity and duration, rainwater harvesting does not provide peak discharge rate attenuation. While rain is a relatively clean source of water, the initial runoff from a roof can contain dust, fecal material, and particulate matter that accumulate on the roof. This initial runoff is diverted from the cistern by the first-flush diverter. Rainfall is a source of nitrogen from atmospheric deposition. Harvesting rainfall results in a reduction in the nitrogen load as well as other pollutants. To achieve a desired average annual load reduction, the cistern must be designed with the target annual average volume reduction, harvesting rate, and water use rate, in mind.

The roof must have gutters or drains with the appropriate screens to collect the rainwater. The site must have adequate space for a cistern and may need to be anchored to a structure. There must be a use for the harvested rainwater. A makeup water source may be required for periods of low rainfall. Stormwater and graywater (including air conditioner condensate) are the first choices for irrigation systems. Make-up water within an occupied space will likely be potable water. Potable water supplies must be separated using a backflow prevention device. An air gap is preferred.

### 5.11.3. Required Treatment Volume

Since a Rainwater Harvesting System is only used to capture roof runoff, a relatively small part of the overall runoff in a development, it functions as a component of a [BMP Treatment Train](#). Accordingly, it will only provide part of the required pollutant load reduction. The rainwater harvesting storage volume may be determined by calculating the volume of water necessary to sustain the desired water use: irrigation, graywater, or potable water supply. The applicant will size the cistern to satisfy the water-use demand. Using the calculated cistern volume, the applicant may then calculate the harvesting rate normalized to the roof catchment area. This volume is used to determine a runoff-capture efficiency using the curve provided in Figure 5.11.1. It should be noted that Figure 5.11.1 is a Rate Efficiency Volume (REV) curve for a constant daily water demand in Alachua County. If the daily demand is expected to vary by more than 10%, either the lowest expected daily demand must be used on Figure 5.11.1 or the average annual reduction in runoff from the roof must be demonstrated using a continuous simulation based on at least 20 years of rainfall data.

**Figure 5.11.1. Rate Efficiency Volume (REV) Curve for a Rainwater Harvesting System in Alachua County with Constant Daily Demand**

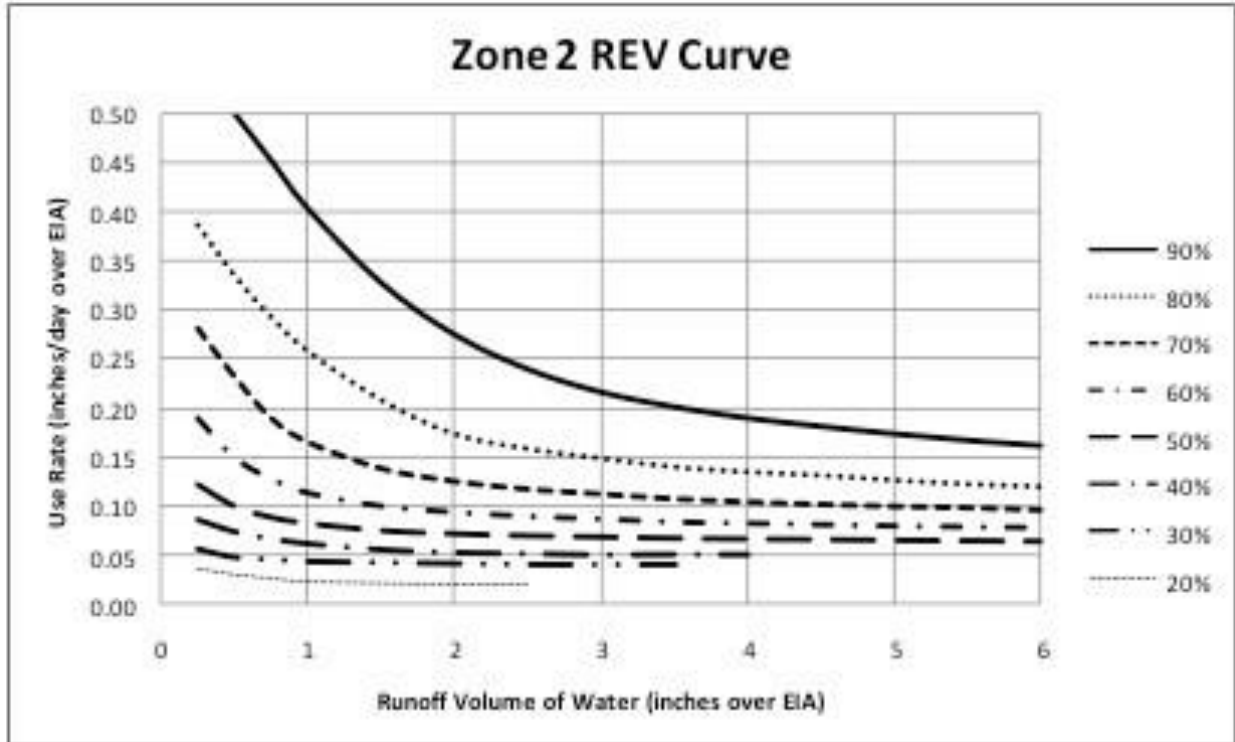

**5.11.4. Design Criteria**

The following criteria are considered minimum standards for the design of a rainwater harvesting system for stormwater credit in Alachua County. The applicant should consult with the appropriate WMD, the [Florida Building Code for Plumbing](#) (Florida, 2014), or its successors, and the Alachua County Health Department to determine if there are any variations to these criteria or additional standards that must be followed.

1. Catchment System

- The gutters, downspouts, drains, and pipes for the collection system must be directed to a cistern.
- Gutters and drains must be protected and covered with a removable screen to prevent debris from clogging drains.
- For every inch of rain that falls on a roof area of 1,000 square feet, approximately 600 gallons of rainwater may be collected. One inch of rain falling on a square foot surface yields approximately 0.6 gallons of water. Due to water loss in the system, it is estimated that about 75% of the harvested rainfall can be captured or 0.46 gallons.



- The first flush of rainwater, equivalent to the first gallon of runoff per 100 square feet of roof area, must be discarded after each rain event to ensure only the cleanest water is stored in the cistern. This is accomplished by installing a first flush diverter before the cistern, typically within the downspout. The diverted rainwater is routed to a vegetated area such as a rain garden. Several manufacturers offer proprietary first-flush diverters; some of these diverters use a vortex to separate debris while reducing the need for maintenance. A schematic of a simple first-flush diverter is shown in the adjacent figure.

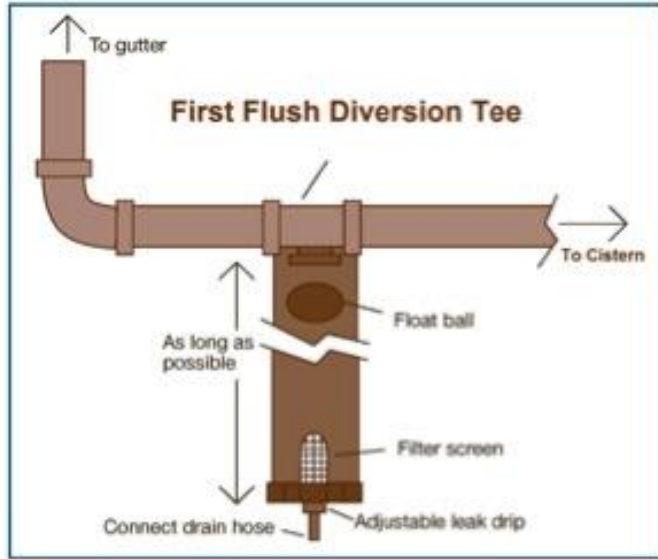

2. Filtering System

- Irrigation systems require pre-filtering to remove particles that may affect valve and sprinkler operation. The filtering system should be designed in accordance with the requirements of the irrigation system.
- Indoor graywater (flushing and laundry) systems require pre-filtering and fine filtering to between 5 and 20 microns.

3. Cistern

- The cistern may be installed below or above ground. If aboveground storage is used, it must be UV stable. The cistern must inhibit algal growth without biocides or toxic substances. This criterion may be met simply with an opaque tank.
- The installation must follow the Florida Building Code for Plumbing and the [Florida Building Code for Electrical](#).
- Prevention of unintentional entry by humans or vermin must be part of the design. Also inspection and cleaning access with venting and appropriate safety signs must be provided.
- The water supply line (e.g., irrigation line or graywater line) must be metered and have a filter.
- An overflow drain is required. It must be sized to accommodate the 100-year/ 24-hour design storm flows. The appropriate downstream erosion controls must be made.
- The cistern size (dedicated water volume) must be determined based on the water use.
- An auxiliary back-up water supply must be provided. Graywater (including air conditioner condensate) is preferred for irrigation systems, but other sources should be considered. If reclaimed water is used, it must be fully used during the intended irrigation cycle and proper signage should be added.

4. Irrigation system

- Irrigation water is supplied from a cistern.
  - Irrigation rates and timing must comply with current watering restrictions.
  - Rain sensors or soil moisture sensors for irrigation shut off must be provided.
  - Watering restrictions are applicable to irrigations systems supplied with rainwater.
  - Backflow prevention devices on any auxiliary back-up source must be provided.
5. Graywater system
- Asphalt shingles and cedar shakes may not be used as a roofing material for the catchment area for a graywater or potable water system. These materials can leach potentially toxic materials such as copper oxide and petroleum products. (Texas, 2007)
  - Harvested rainwater is supplied from a cistern for graywater use within an occupied space.
  - Filters are required between the pump and the connection to the plumbing system to provide pre-filtering and fine filtering to between 5 and 20 microns.
  - Backflow prevention devices on any auxiliary back-up source must be provided.
  - The Alachua County Health Department and the Alachua County Development Services must approve all Rainwater Harvesting Systems that connect to a plumbing system within an occupied space. These systems may have additional design and maintenance requirements.
6. Discharge Requirements - A Rainfall Harvesting System typically will have two discharges: the water diverted from the first flush and the cistern overflow. The appropriate erosion control must be made downstream of both discharges. Where possible, the first-flush water must be discharged to a rain garden or other landscaped area.
7. Safety Considerations - Safety considerations to be addressed for all rainwater harvesting designs include but are not limited to the following:
- Access to the pump and cistern must be controlled.
  - Safety features may include fencing and signage depending on the site and use of water.
  - Depending on the end use, electrical back-up when power is down is recommended as part of emergency operations.
  - All pipes that transport water for harvesting must be labeled as 'Non-potable. Do not drink.' unless the system is approved by the Alachua County Health Department for potable use.
  - Large cisterns and vaults may require entry for maintenance and inspection.
  - These systems must provide appropriate safety equipment for a confined space.
  - The Rainwater Harvesting System must be separated from the potable water supply with a backflow prevention device, preferably consisting of an air gap.
8. Additional Design Considerations - A Rainfall Harvesting System may include the following, depending on the system's design:
- Lighting and electrical outlets.
  - Signage with education and safety language.
  - A leak detection system for the cistern.
9. Additional Permitting Considerations

- The rainwater harvesting system may require a SWFWMD water use permit.
- The rainwater harvesting system may require a permit from the Alachua County Health Department.
- The rainwater harvesting system will require a permit from the Alachua County Development Services to include electrical, plumbing, and structure anchoring.

#### **5.11.5. Construction Requirements**

Rainwater harvesting systems typically are used in conjunction with rain gardens and secondary water uses such as irrigation. To assure proper construction of the stormwater harvesting system the following construction procedures are required:

1. Install the Catchment System including the gutters, screens, diverter, and cistern.
2. Construct the rain garden or landscaping area that will receive the first flush discharge and ensure that it is stabilized with appropriate vegetation before operation begins.
3. Construct the associated irrigation system in accordance with all permitted design specifications and irrigation system design standards. If appropriate, construct the components of the nonpotable or potable uses for rainwater in accordance with all design and code specifications.
4. Assure that all irrigation components are properly sited and that irrigation spray heads are working properly and not spraying irrigation water onto impervious areas.
5. Test all components of the system to ensure there are no leaks or other malfunctions.

#### **5.11.6. Inspection, Operation, and Maintenance**

Maintenance issues associated with Rainwater Harvesting Systems are related to the proper functioning of the filter system and of the pump and irrigation system. Rainwater Harvesting Systems must be inspected regularly by the operation and maintenance entity to determine if it is operating as designed and permitted. Reports documenting the results of annual inspections shall be filed with the County every two years.

##### 1. Inspection Items:

- Inspect operation of the Rainwater Harvesting System to assure that the pump, flow meter, and filter system are operating properly and achieving desired flow volumes.
- Inspect the operation of the Rainwater Harvesting System to assure proper operational and, with respect to the irrigation system, inspect the pump, timer, distribution lines, and sprinkler heads to assure they are working properly.

##### 2. Maintenance Activities As-Needed To Prolong Service:

- Repair any components of the Rainwater Harvesting System that are not functioning properly and restore proper flow and filtration of stormwater.
- Repair or replace any damaged components of the Rainwater Harvesting System and irrigation system as needed for proper operation.

##### 3. Record keeping

The owner/operator of a Rainwater Harvesting System must keep a maintenance log of activities that is available at any time for inspection or recertification purposes. The log will include records related to the operation of the Rainwater Harvesting System and the use of the harvested rainwater for irrigation or other approved purposes to demonstrate that the permitted nutrient load reduction is being achieved. A totalizing flow meter to measure the

quantity and day/time of pumping and irrigation is required. The maintenance log shall include the following:

- Rainwater volume harvested using a flow meter specifying the day, time, and volume;
- Rainwater volume irrigated or otherwise used using a flow meter specifying the day, time, and volume used;
- Observations of the Rainwater Harvesting System operation, maintenance, and a list of parts that were replaced;
- Observations of the irrigation system operation, maintenance, and a list of parts that were replaced; and
- Dates on which the Rainwater Harvesting System and irrigation (or other use systems) were inspected and maintenance activities conducted.

## 5.12. Wet Detention Systems

### 5.12.1. Description

Wet detention systems are permanently wet ponds that are designed to slowly release a portion of the collected stormwater runoff through an outlet structure. A schematic of a typical wet detention system is shown in Figure 5.12.1.

Wet detention systems are often an effective BMP for sites with moderate to high water table conditions. Wet detention treatment systems provide removal of both dissolved and suspended pollutants by taking advantage of physical, chemical, and biological processes within the pond. They are relatively simple to design and operate, provide a predictable recovery of storage volumes within the pond, and are easily maintained by the maintenance entity.

There are several components in a wet detention system that must be properly designed to achieve the level of stormwater treatment described herein. A description of each design feature and its importance to the treatment process is presented below. The design and performance criteria for wet detention systems are discussed below.

#### WET DETENTION SYSTEM SUMMARY

Advantages/Benefits	Reduces peak discharge rate and pollutant loadings. May have some infiltration depending on soil, SHGWT conditions, and control elevation. Provides a source of fill, creates “waterfront property” and enhanced site aesthetics.
Disadvantages/Limitations	Can require large footprint. Lower pollutant load reductions than provided by retention BMPs. Do not construct within 75 feet of a public or private potable water supply well or within 75 feet of an on-site wastewater disposal and treatment system.
Volume Reduction Potential	Low
Pollutant Removal Potential	Low to moderate for all pollutants. TN load reduction ranges from 30 to 40% while TP load reduction varies from 50 to 80%.
Key design considerations	Pollutant removal directly related to residence time and permanent pool volume; control elevation above the SHGWT; depths over 12 feet generally prohibited unless aeration provided; flow path ratio greater than 0.80; recovery half of bleed-down volume within 24 to 30 hours; of treatment volume within 24 – 72 hours; side slopes no steeper than 4:1 unless fenced; sides must be stabilized with vegetation or other approved materials



Key construction and maintenance considerations

Can use for erosion and sediment control during construction but may have to remove sediment; ensure all inlets and outlets are well stabilized; use energy dissipaters as needed to prevent scour; inspect for accumulating sediment and impact on storage volume; inspect and keep inflows, outflows, skimmers, etc. clear of debris or trash and structurally sound; identify and eliminate mosquito breeding problems.

Figure 5.12.1. Typical Cross Section of a Wet Detention System

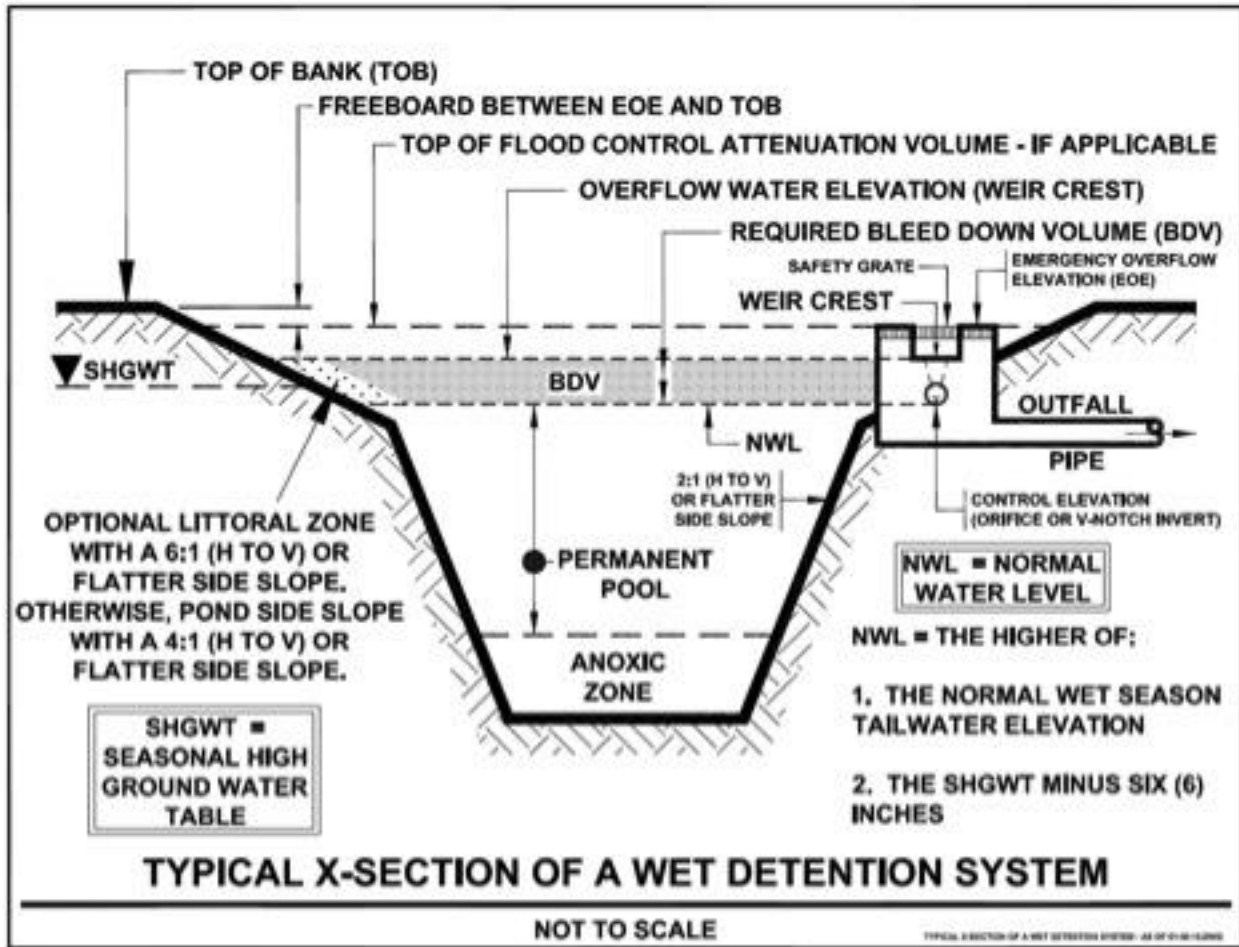

**5.12.2. Treatment required**

The required nutrient load reduction will be determined by type of water body to which the stormwater system discharges and the associated performance standard as set forth in [Section 4.3](#) of this Manual.

**5.12.3. Bleed-down Volume**

The bleed down volume shall be the first one inch of runoff from the contributing area. For wet detention systems, the bleed-down volume is defined as the zone between the elevation of the overflow weir and the control elevation. The overflow weir is generally set to accommodate

stormwater quantity and flood control criteria. The control elevation is the “normal” water level for the pond. It is established as the higher elevation of either the normal wet season tailwater elevation or the [SHGWT](#), unless this creates adverse impacts to wetlands at or above the control water table elevation. The maximum stage above the control elevation for providing the bleed-down volume shall not exceed 18-inches unless the applicant demonstrates, based on plans, test results, calculations or other information, that an alternative design is appropriate for the specific site conditions.

#### 5.12.4 Design Criteria

1. **Required nutrient reduction** - The wet detention system, either by itself or as part of a BMP treatment train, shall achieve the required level of nutrient load reduction as specified in *Section 5.3* of this Manual.
2. **Permanent Pool** - The most significant component and design criterion with respect to nutrient load reduction of a wet detention system is the storage capacity of the permanent pool (i.e., the section of the pond that always holds water). Important pollutant removal processes that occur within the permanent pool include: uptake of nutrients by algae, adsorption of nutrients and heavy metals onto bottom sediments, biological oxidation of organic materials, and sedimentation. Uptake by algae is one of the most important processes for the removal of nutrients. Sedimentation and adsorption onto bottom sediments is likely the primary means of removing heavy metals.
3. The permanent pool shall be sized to provide an annual average [residence time](#) that achieves the required nutrient removal efficiency, if possible. It is recognized that required treatment efficiencies may not be achievable with a wet detention system alone, due to inherent limitations associated with this BMP. Residence time shall be based upon annual rainfall volumes. Also, it is recognized that wet detention systems used in-series also have limitations regarding the maximum treatment that can be expected, resulting in so-called irreducible concentrations, below which the BMP is incapable of treating. Irreducible concentrations for TN and TP are established as 0.40 and 0.010 mg/L, respectively. In the case where the wet detention system alone cannot achieve the required treatment efficiency, a BMP treatment train must be used that incorporates other complementary BMPs.
4. The relationship between removal efficiency of total phosphorus in wet detention ponds as a function of mean annual residence time is given in Figure 5.12.2. The best-fit relationship for the remaining data was obtained using a second-order relationship involving the natural log of the residence time. The best-fit equation is also provided on Figure 5.12.2 for the relationship between total phosphorus removal efficiency and residence time. This equation provides an extremely good fit between the two variables, with an  $R^2$  of 0.979. This value indicates that residence time explains approximately 97% of the observed variability in removal efficiencies for total phosphorus in wet detention ponds.
5. Relationships between mean annual residence time and removal efficiencies for total phosphorus in wet detention ponds for stormwater are illustrated in Figure 5.12.3. The best-fit for the relationship between removal efficiency and residence time for total nitrogen was obtained using a hyperbolic equation for stormwater. The final version of this equation is also summarized on Figure 5.12.3. The  $R^2$  value of 0.800 suggests that residence time explains approximately 80% of the observed variability in removal efficiencies for total phosphorus in wet detention ponds.

**Figure 5.12.2. Removal Efficiency of Total Phosphorus in Wet Detention Ponds as a Function of Residence Time**

(From [Evaluation of Current Stormwater Design Criteria within the State of Florida](#), Final Report Submitted to the FDEP, June 2007, Harvey Harper and David Baker, Environmental Research and Design, Inc.)

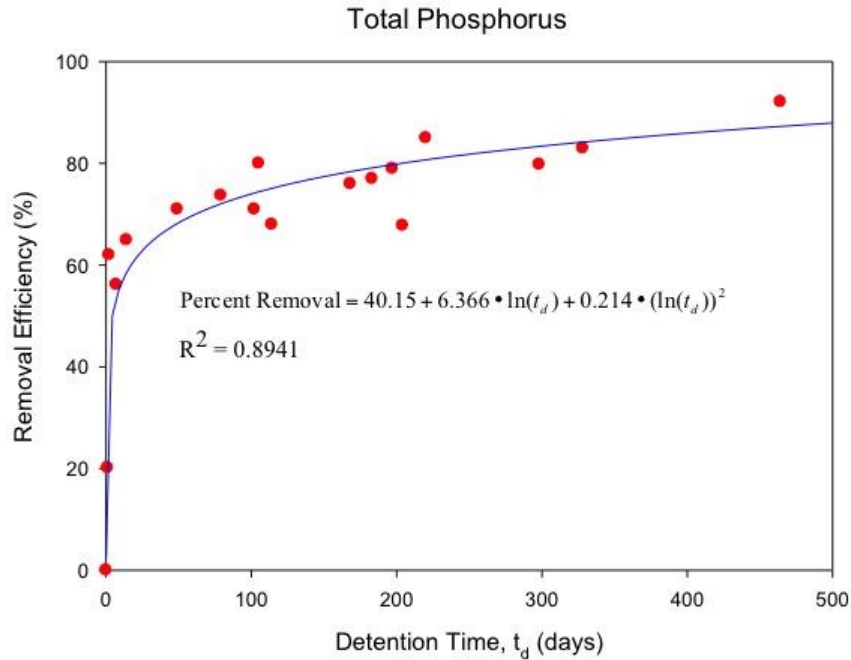

**Figure 5.12.3 Removal Efficiency of Total Nitrogen in Wet Detention Ponds as a Function of Residence Time**

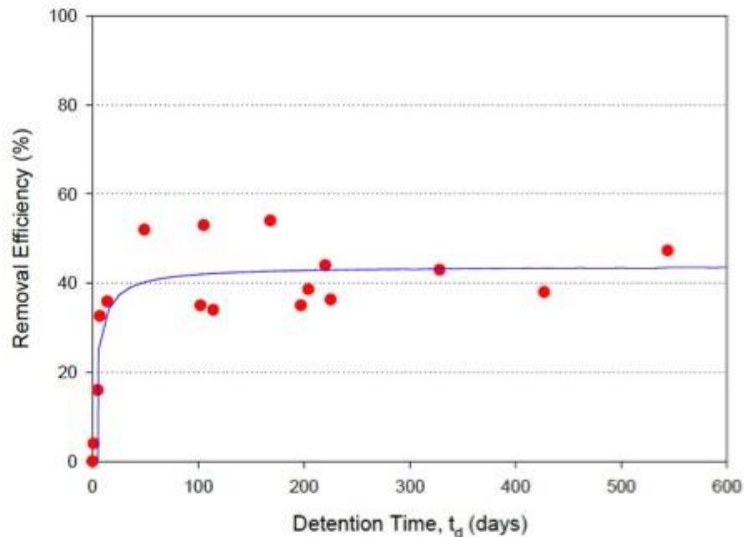

To make it easier to determine the pollutant load reduction associated with varying residence time, Table 5.12.1 is provided below.

**Table 5.12.1. Relationship between TP and TN Load Removal and Wet Detention Residence Time**

<i>RESIDENCE TIME</i>	<i>TP REMOVAL</i>	<i>TN REMOVAL</i>	
	$Eff = 44.53 + (6.146 \cdot \ln Td) + (0.145 \cdot (\ln Td)^2)$	$Eff = (43.75 \cdot Td) / (4.38 + Td)$	
14	61.51	33.32	
21	64.12	36.20	
30	66.42	38.18	
50	69.71	40.23	
100	74.01	41.91	
150	76.78	42.51	
200	78.63	42.81	
250	80.07	43.00	

- 6. Pond Depth** – The maximum depth to be used in calculating the water quality permanent pool volume shall be no greater than 12 feet, unless the applicant demonstrates, based on Equation 5.12.1, that an alternative depth is appropriate for the specific site conditions. The maximum allowable permanent pool depth as it relates to the aerobic zone is directly related to the anticipated algal productivity within the pond. The maximum depth of the pond may be deeper, provided the applicant demonstrates that permanent pool credit for deeper pond depths only includes volumes that are based on the depth below the control elevation that remains aerobic throughout the year (based on a monthly analysis). The general relationship for determining the depth to anoxic conditions is expressed as the following equation:

**Equation 5.12.1:**

$$\text{Depth of DO} < 1 = 3.035 * \text{Secchi} + 0.02164 * (\text{chl-a}) - 0.004979 * \text{Total P}$$

- Where:
- DO = dissolved oxygen (mg/L)
  - Secchi = estimated Secchi depth (meters)
  - Chyl a = estimated chlorophyll a (mg/m3)
  - Total P = estimated total phosphorus (ug/L)

7. The above calculation must be performed on a monthly basis in order to determine the most limiting time of year (month with shallowest depth to the anoxic zone). Alternatively, the depth to the anoxic zone can be calculated using Equation 5.12.1 for average annual conditions, and multiplying the resultant depth by 0.75. Additional methods and assurances shall be required if the wet pond is anticipated to receive sediment or nutrient loads greater than those calculated from the EMCs since Equation 5.12.1 may not be applicable for that condition.
8. The mean pond depth shall be at least 6 (six) feet unless an applicant demonstrates that an alternative depth is appropriate for the specific site conditions. The mean pond depth is calculated by dividing the pond volume at the normal water level elevation by the surface area of the pond at the normal water level elevation. The mean depth requirement is necessary to ensure a minimum depth throughout the pond that will reduce opportunities for

nuisance plant species to be established. If a shallower mean depth is proposed for the site, the permittee shall be required to implement additional operating and maintenance provisions prevent the system from becoming dominated by cattails or other undesirable vegetation.

- 9. Pond Configuration** - It is important to maximize the flow path of water from the inlets to the outlet of the pond to promote good mixing of stormwater. Under these design conditions, short circuiting is minimized and pollutant removal efficiency and mixing is maximized. The flow weighted average inlet to outlet ratio, or flow path ratio (FPR), shall be 0.80 or greater, using the following methodology:

For each inlet, using the percent of inflow, calculate the FPR using Equation 5.12.2

**Equation 5.12.2** Flow Path Ratio (FPR) =  $\text{SUM} ((A/LP)_i * V_i)$

Where:  $A_i$  = actual travel distance for inflow  $i$

$LP_i$  = longest possible travel distance for inflow  $i$

$V_i$  = fraction of annual runoff volume contributed by inflow  $i$

If short flow paths are unavoidable, the effective flow path can be increased by adding diversion barriers (islands, peninsulas, or baffles). Inlet structures shall be designed to dissipate the energy of water entering the pond.

- 10. Control Elevation** - The control elevation is the “normal” water level for the pond. The control elevation shall be established as the higher elevation of either the normal wet season tailwater elevation or the SHGWT minus six inches, unless this creates adverse impacts to wetlands at or above the control water table elevation. However, specific site conditions may allow deviation from this requirement. Accordingly, an applicant may request the County/City approve another control elevation based upon evaluation of the proposed elevation on:

- Maintaining existing water table elevations in existing well field cones of depression;
- Maintaining water table elevations needed to preserve environmental values at the project site and prevent the waste of freshwater;
- Maintaining minimum flows or levels of surface waters established pursuant to Section 373.042, F.S.
- Assuring that water table elevations will not be lowered such that the existing rights of others will be adversely affected;
- Preserving ground water recharge characteristics of the project site;
- Maintaining ground water levels needed to protect wetlands and other surface waters;
- Creating adverse impacts on surrounding land and project control elevations and water tables;
- Creating conflicts with water use permitting requirements or water use restrictions;

The County/City will approve an alternative control elevation and its effects on the factors based on a demonstration by the applicant, using plans, test results, calculations or other information, that the alternative design is appropriate for the specific site conditions and will meet the above considerations.

- 11. Ground water nutrient loads** - If the control elevation is located more than six inches below the SHGWT, nutrient loads from base flows must be accounted for in the nutrient loading and nutrient removal calculations.



12. **Reclaimed water nutrient loads** – If reclaimed water is discharged into a wet detention system that will discharge, the nutrient loads from the reclaimed water must be accounted for in the nutrient loading and nutrient removal calculations. One way to do this is to increase the EMCs by 50%.
13. **Recovery Time** - The outfall structure shall be designed to drawdown one half of the required bleed-down volume within 24 hours to 30 hours. If the minimum bleed-down device specified in 11 below will result in a quicker drawdown it will be allowed.
14. **Outlet Structure** - The outlet structure generally includes a drawdown device (such as an orifice, "V" or square notch weir) set to establish a normal water control elevation and slowly release the bleed-down volume (see Figures 5.12.4 and 5.12.5 for schematics). The design of the outfall structure must also accommodate the passage of base flows or flows from upstream stormwater management systems, if applicable (see Figure 5.12.6).

Also, drawdown devices shall incorporate minimum dimensions no smaller than 2 inches minimum width or less than 20 degrees for "V" notches. Bleed-down devices incorporating dimensions smaller than 6 inches minimum width or less than 45 degrees for "V" notches shall include a device to minimize clogging. Examples of such devices include baffles, grates, screens, gravel filled corrugated metal pipes, and pipe elbows.

15. **Pond Side Slopes** –For purposes of public safety, wet detention basins shall be restricted from public access or contain side slopes that are no steeper than 4:1 (horizontal: vertical) from the top of bank out to a depth of two feet below the control elevation. Either vegetation or other materials can be used to stabilize side slopes and minimize erosion and subsequent sedimentation. Deeper areas of the pond must maintain horizontal to vertical side slopes no steeper than 2H:1V provided geotechnical evidence is provided that such slopes will be stable.
16. **Littoral Zones** - If the applicant proposes to include a littoral zone, the design shall meet the requirements in [Section 5.15](#) of this Manual.
17. **Removal of Exotic or Nuisance Plant Species** – In wet detention ponds without a littoral zone, exotic or nuisance species such as cattails or primrose willow shall be removed as necessary to prevent their long-term establishment.
18. **Setback from Potable Wells and Septic Tanks** – Wet detention systems shall not be constructed within 75 feet of a public or private potable water supply well or within 75 feet of an on-site wastewater disposal and treatment system.

#### 5.12.5. Required Site Information

Successful design of a wet detention system depends heavily upon conditions at the site, especially information about the soil, geology, and water table conditions. At a minimum, site specific information on the depth to the seasonal high ground water table and the presence and location of aquitard/confining unit is required when designing a wet detention system. Information related to determining the SHGWT, the location of aquitards/confining layers, and hydraulic conductivity (if applicable for radius of influence and ground water inflow computations) is specified in [Appendix C](#) of this Manual.

Figure 5.12.4. Typical Wet Detention Outfall Structure (N.T.S.)

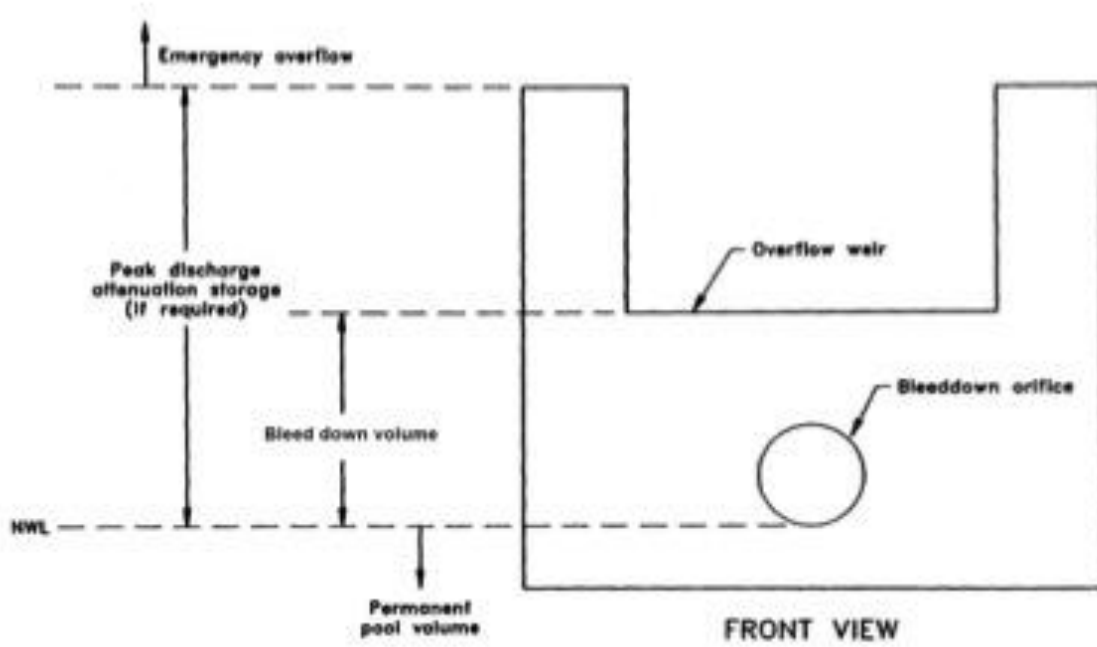

Figure 5.12.5. Typical Wet Detention Outfall Structure with "V"-notch Weir (N.T.S.)

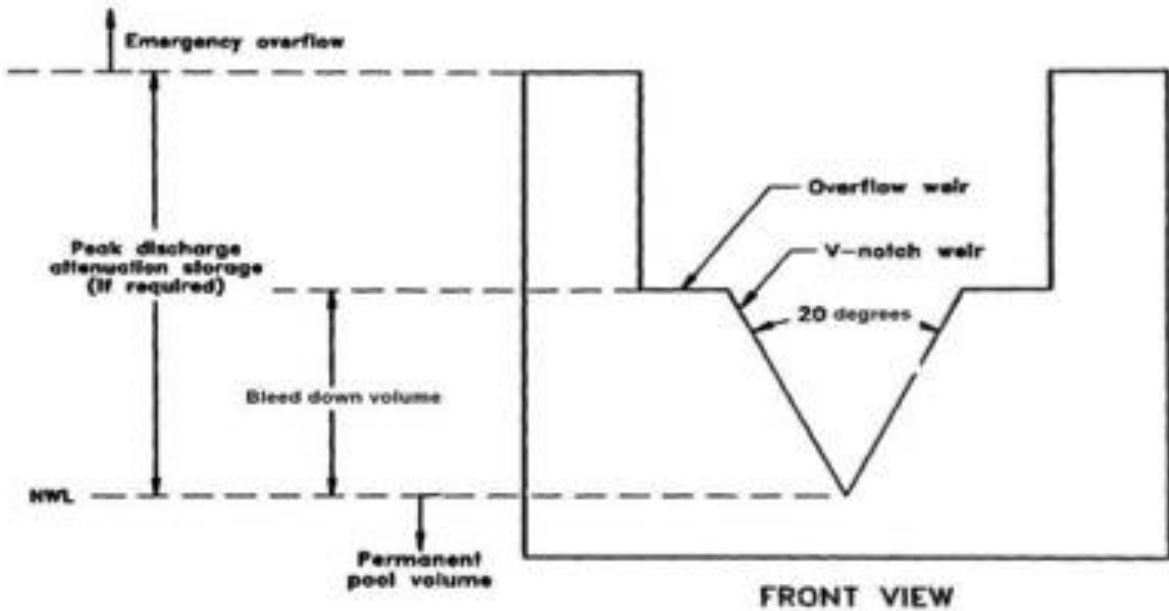

Figure 5.12.6. Typical Wet Detention Outfall Structure With and Without Baseflow Conditions (N.T.S.)

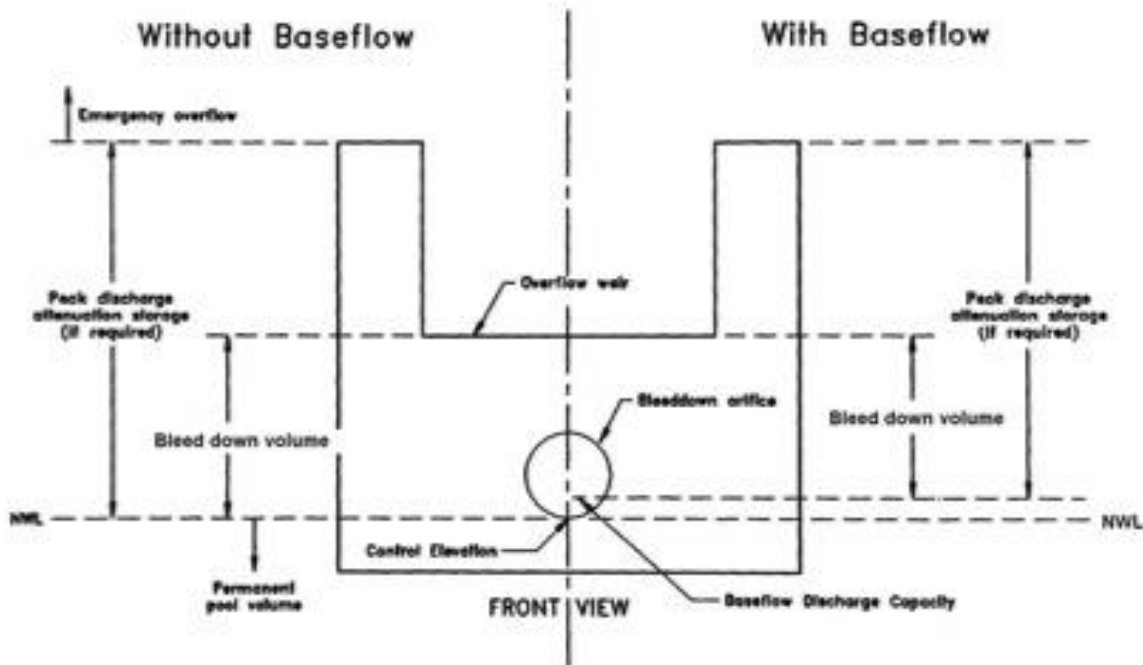
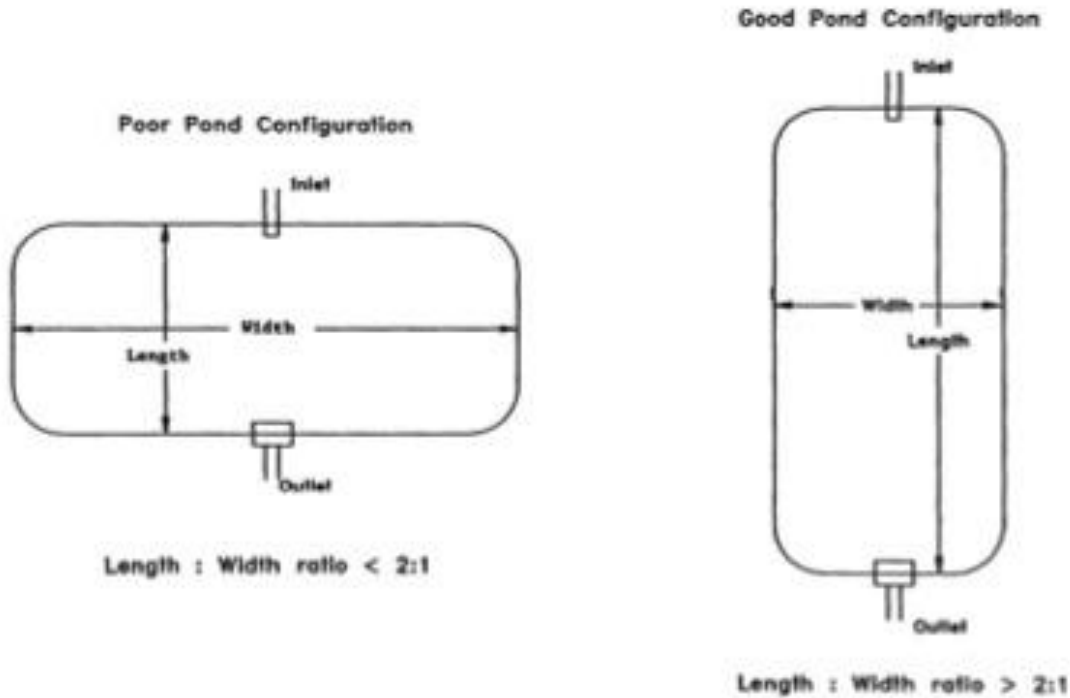

Figure 5.12.7. Examples of Good and Poor Wet Detention Pond Configurations (N.T.S.)



**5.12.6. Detention Pond Construction**

Wet detention basin construction procedures are important in assuring the long term operation and safety of the system, especially if the pond is constructed using an embankment rather than through excavation. In either case, it is important that the discharge structure be properly designed and constructed to prevent its failure.

The following construction procedures are required to assure proper construction of the wet detention pond:

1. The location and dimensions of the detention pond shall be verified on-site prior to its construction. All design requirements including detention pond dimensions and distances to foundations, septic systems, and wells need to be verified.
2. Once excavation of the wet detention pond begins, the soil types need to be verified to ensure that they are suitable for the pond.
3. If the wet detention pond is being created by construction of an embankment, rather than solely through excavation, special attention during construction must be focused on the embankment's construction, especially of any pipes that are part of the discharge structure that are built through the embankment.

To minimize the potential that an embankment will fail, inspection of the structure throughout its construction are needed to assure that components such as anti-seep collars or diaphragms and soil compaction are done properly.

4. All elevations need to be verified in the field as construction occurs to assure that they are consistent with permitted plan specifications.

5. All inlets and outlets shall be stabilized as set forth in the permitted plans to prevent erosion, scour, and sedimentation.
6. An applicant may propose alternative construction procedures to assure that the design infiltration rate of the constructed and stabilized retention basin is met.

### 5.12.7. Inspections, Operation and Maintenance

Maintenance issues associated with wet detention ponds include assuring that sediments are not accumulating to such a degree that they are decreasing the required storage volume and assuring that all inlets, outlets, and discharge structures are not clogged or damaged structurally.

#### 1. Inspection Items:

- Inspect basin for excessive sediment accumulations that decrease the wet detention pond's permitted storage volume.
- Inspect inflow and outflow structures, trash racks, skimmers, and other system components for accumulation of debris and trash that would cause clogging and adversely impact operation of the wet detention pond.
- If an embankment is used, inspect to ensure that no piping of water is occurring through the embankment and that there is no damage or structural integrity issues.
- Inspect vegetation on side slopes to assure it is healthy, maintaining coverage, and that no erosion is occurring.
- Inspect the wet detention pond for potential mosquito breeding problems
- Inspect wet detention pond and, if applicable, littoral zone to assure that cattails or other invasive vegetation are not becoming established.

#### 2. Maintenance Activities As-Needed To Prolong Service:

- If needed, remove accumulated sediments to restore permitted storage volume and dispose of properly. Please note that stormwater sediment disposal may be regulated under [Chapter 62-701](#), F.A.C.
- Remove trash and debris from inflow and outflow structures, trash racks, and other system components to prevent clogging or impeding flow.
- Maintain healthy vegetative cover to prevent erosion of side slopes or around inflow and outflow structures. Remove any trees or shrubs that may have become established on the discharge structure embankment, if applicable.
- Eliminate mosquito breeding habitats such as thick growths of cattails and ensure that mosquito fish are present in the wet detention pond.
- Remove cattails and other exotic vegetation from the littoral zone, if applicable, and replant appropriate vegetation if needed to meet littoral zone requirements.

### 5.12.8. Calculating Annual Residence Time

As seen in Figures 5.12.2 and 5.12.3, the average TN and TP load reduction in a wet detention system is directly related to the annual residence time that the stormwater spends within the system before discharge. The longer the residence time, the more time that the various pollutant load reduction mechanisms within the wet detention system can function. The basic formula for calculating residence time is shown below as Equation 5.12.3.

**Equation 5.12.3.**      $R_t = V/Q$



Where:  $R_t$  is residence time (days)

$V$  is the volume of the wet detention system permanent pool ( $\text{ft}^3$ )

$Q$  is the average flow rate for the period of time ( $\text{ft}^3/\text{day}$ ).

This units and time frame is usually tied to the prediction of effectiveness or the way effectiveness was determined. As an example, for wet detention, the effectiveness relationship is to the average annual flow values and using the permanent pool. Thus  $V$  is the permanent pool in cubic feet,  $Q$  is the average flow is cubic feet/day, and time is in days. Questions always arise on the calculation of  $Q$  as inflow or outflow. Inflow is usually larger and thus there is a more conservative estimate of time (time is lower). Additionally, outflow  $Q$  may not be possible to calculate until a final design, and ground water input into a pond can affect the outflow. Therefore, the inflow  $Q$  should be used in the calculations.

### 5.13. Stormwater Harvesting Systems

#### 5.13.1. Description

Stormwater harvesting systems use treated stormwater for beneficial purposes thus reducing the stormwater volume and mass of pollutants discharged from a retention or wet detention system. It is most often used with wet detention as part of a BMP treatment train. The harvested stormwater can be used for numerous uses including irrigating lawns and landscape beds, irrigating green roofs, washing vehicles, industrial cooling and processing, and toilet flushing. To properly design a stormwater harvesting system that will result in a predictable average annual mass removal, water budgets are required. A water budget is an accounting of water movement on to, within, and off an area. The development of a water budget for stormwater harvesting is done to quantify the reduction in off-site discharge for a given time period. Individual components of storage volume, rate of use, and discharge can be accounted for in the water budget. Calculation of these components requires knowledge of many variables, such as: watershed characteristics, water use volumes and rates, desired percentage of stormwater runoff to be used, maximum volume of stormwater runoff storage, rainfall data, and evaporation data.

The results of long-term simulations of stormwater harvesting ponds over time are presented as Rate-Efficiency-Volume (REV) curves. The REV curves shall be used to design stormwater harvesting systems to improve the nutrient removal effectiveness of wet detention ponds such that these systems meet the performance standards described in [Section 4.3](#) of this Manual. Stormwater harvesting curves (REV curves) are provided in [Section 5.13.7](#) of this Manual.

Important assumptions that must be understood when using the REV curves include:

- Net ground water movement into or out of the pond is assumed to be zero over the period of simulation.
- The use rate is kept constant for each month in a year, and presented on the REV curves as an average rate per day and over the equivalent impervious area (EIA).
- The effectiveness results are long term averages based on historical rainfall records. The average values for each year will be different because of annual rainfall volumes and distribution.
- Soil storage in the irrigated area and plant ET are not limiting irrigation application rates.

It should be noted that a supplemental water supply is needed in the dry season when the pond harvested volume is typically depleted. Also, for a design of a stormwater harvesting system which does not meet one of the above assumptions, the applicant can develop a site-specific water budget analysis to meet the required performance standard and design criteria.

#### STORMWATER HARVESTING SYSTEM SUMMARY

Advantages/Benefits	Reduces the volume of stormwater discharged from a wet detention system thereby increasing treatment effectiveness; reduces potable water use and reuses stormwater for irrigation and other nonpotable purposes; provides ground water recharge and water reuse.
Disadvantages/Limitations	Requires a pump, flow meter, and filtration system, depending on the determined uses of harvested stormwater; need area to be

	irrigated or other use of the water; may require a Water Use Permit from SJRWMD or SRWMD.
Volume Reduction Potential	Moderate to High depending on use for harvested stormwater, size of irrigation area, and irrigation rate and schedule.
Pollutant Removal Potential	Moderate to High for all pollutants
Key design considerations	Determine use for harvested stormwater (irrigation, graywater, potable); determine equivalent impervious area, harvesting rate, volume, irrigation method, and equipment; use Rater-Efficiency-Volume (REV) curve to specify storage volume and harvesting rate; filter harvested stormwater through horizontal wells or equivalent filter systems; obtain additional requirements for graywater or potable use from Alachua County Health Department; recovery of bleed-down volume within 24 – 30 hours;
Key construction and maintenance considerations	Ensure proper construction of retention or wet detention system; assure that all components of the harvesting and reuse system are properly sited and operational; ensure irrigation spray heads do not direct water onto impervious surfaces; inspect all components of system on regular basis to ensure proper operation; maintain pumping and irrigation records as required.

**5.13.2. Treatment required**

The required nutrient load reduction will be determined by type of water body to which the BMP treatment train that includes stormwater harvesting discharges and the associated performance standard as set forth in [Section 4.3](#) of this Manual. The nutrient removal credits associated with stormwater harvesting shall be calculated using the REV Curves and the BMP Treatment Train Equations set forth below. The [BMPTRAINS](#) software may be used to design the system and determine the nutrient removal credits.

**5.13.3. Equivalent Impervious Area**

When designing stormwater harvesting systems, the runoff characteristics of the watershed must be calculated. The overall runoff coefficient (C) for an area composed of different surfaces can be determined by weighting the runoff coefficients for the surfaces with respect to the total areas they encompass, and is based on the rainfall volume used to calculate the maximum volume for use.

$$C = \frac{C_1 A_1 + C_2 A_2 + \dots + C_N A_N}{A_1 + A_2 + \dots + A_N} \quad \text{Equation 5.13.1}$$

where:  $C_N$  = Runoff coefficient for surface N  
 $A_N$  = Area of surface N

This weighted runoff coefficient (*C*) is termed the effective runoff coefficient and is representative of the entire watershed.

The equivalent impervious area (*EIA*) is equal to the product of the total area of the watershed (*A*) and the effective, or weighted, runoff coefficient (*C*) for the watershed:

$$EIA = CA \quad \text{Equation 5.13.2}$$

- where:
- EIA* = Equivalent impervious area (acres)
  - C* = Effective runoff coefficient for the watershed
  - A* = Area of watershed (acres)

The area of the *EIA* is defined as the area of a completely impervious watershed that would produce the same volume of runoff as the actual watershed. For example, a 20 acre watershed with an effective runoff coefficient (*C*) of 0.5 would have an *EIA* of 10 acres (20 ac x 0.5). If one inch of rain fell on this 10 acre impervious area, the runoff volume would be 10 ac-in (10 ac x 1 in). If the same amount of rain fell on the actual watershed the runoff volume would not change:

$$20 \text{ ac} (1 \text{ in}) (0.5) = 10 \text{ ac-in}$$

The *EIA* will be expressed in acres when using this methodology. The use of the *EIA* serves to generalize the model so that it can be applied to a watershed of any size and runoff characteristics or as applied to a volume of water used. The product of inches of water used and the area is a volume term. The *EIA* for a watershed shall include the area of the pond when using this methodology.

**Figure 5.13.1. Typical Cross Section of a Stormwater Harvesting System**

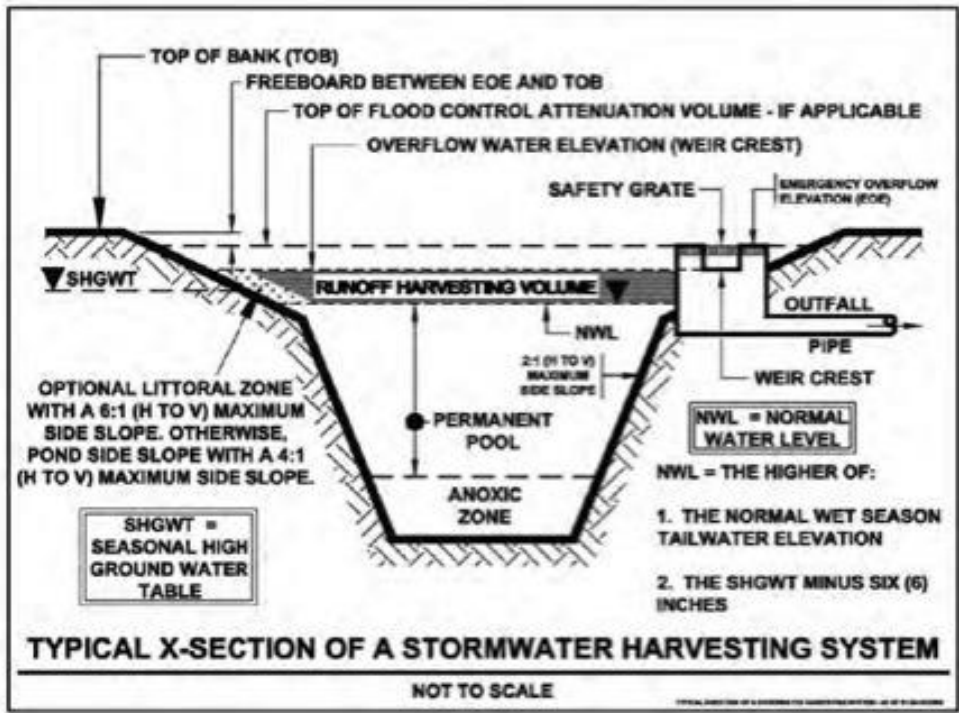

### 5.13.4. Design Criteria

1. The wet detention design criteria in [Section 6.12.4](#) of this Manual, except for 5.12.4.10 and 5.12.4.11, are applicable to stormwater harvesting systems.
2. The stormwater harvesting system shall be designed using the Rate-Efficiency-Volume (REV) Curves and methodology set forth in [Section 6.13.7](#) of this Manual.
3. **Runoff Storage Volume** - The runoff storage volume (V) is similar to the “bleed down volume” or the temporary storage volume in a wet detention pond (Figure 6.13.1). The major difference between a stormwater harvesting pond and a wet detention pond is the operation of the temporary storage volume. For typical wet detention systems, the bleed-down volume is discharged to adjacent surface waters using a flow limiting structure. On the other hand, in a stormwater harvesting pond the runoff storage volume is not discharged to adjacent surface waters but is used for some beneficial purpose.

Runoff storage volumes are expressed in units of inches over the *EIA*. The values can be converted to more commonly used units such as acre feet or cubic feet using simple conversions. It should also be noted that in most cases, stormwater harvesting can provide for most of the water needed but the runoff storage volume will not be sufficient to supply all the water needed over a year, especially in dry periods. Thus a backup supply should be planned. A back up supply is one that provides for less than the majority of water needed. If water is taken from the permanent pool of the wet detention system for irrigation, the applicant must demonstrate that the lowering of the permanent pool will not adversely affect surface waters or wetlands.

4. **Minimum Quality of Harvested Stormwater** – Treated harvested stormwater that is used for irrigation is withdrawn from the stormwater treatment system in a manner that minimizes turbidity, bacteria, pathogens and algal toxins. This can be done by filtering the stormwater to be harvested through a minimum of four (4) feet of native soils or clean sands. This can be accomplished by withdrawing water through a horizontal well configuration located directly adjacent or under the stormwater harvesting pond or by using a mechanical sand or disc filter. See Figures 5.13.2 and 5.13.3 for a detailed schematic of approved withdrawal systems.

Withdrawal of irrigation water from the stormwater harvesting pond in this manner effectively removes algae, turbidity, and other solids that may clog spray heads and materials that may be considered adverse to human health when converted to an aerosol condition.

Acceptable alternatives include in-pipe treatment filtration or a mechanical filter used to remove detained water from ponds. If an applicant proposes to use an alternative to horizontal wells, an affirmative demonstration must be made by the applicant, based on plans, test results, calculations or other information, that the alternative design is appropriate for the specific site conditions, will effectively remove turbidity, pathogens, and algae toxins to prevent adverse impacts.

5. **Acceptable Use Rates of Harvested Stormwater** - In addition to water quality considerations, stormwater harvesting systems shall be designed and operated in such a manner to prevent adverse impacts to wetlands or surface waters. A common application of the treated stormwater involves an area to be irrigated. For instance, an apartment complex may irrigate natural vegetation, turf grass, and other landscaped common areas. The average yearly demand of turf grass irrigation systems in Florida is usually less than one inch per week on the average over a year. The designer shall consult a landscape irrigation specialist for the design of the irrigation system and the recommended irrigation rates. **Applicants are advised that a WUP or CUP may be required for stormwater harvesting systems and that the use rates and design shall be consistent with WUP or CUP requirements.**



- Rate of Use and Metering of the Harvested Stormwater** - The rate of use (R) is a variable over time and must be recorded. On the REV curves, the rate of use units is expressed as average inches per day over the EIA. The values can be converted to more practical units such as gallons per day or acre feet per week using simple conversions. A meter or other reporting device must monitor the use rate. The records of use must be documented in a logbook to demonstrate that the required pollutant load reductions (achieved through reduced volume of discharge) are being met.

**Figure 5.13.2. Schematic for a Typical Stormwater Harvesting Pond**  
(from FDOT BD 521-03, Regional Stormwater Facilities, December 2007)



**Figure 5.13.3. Schematic for Two Typical Stormwater Harvesting Withdrawal Systems**

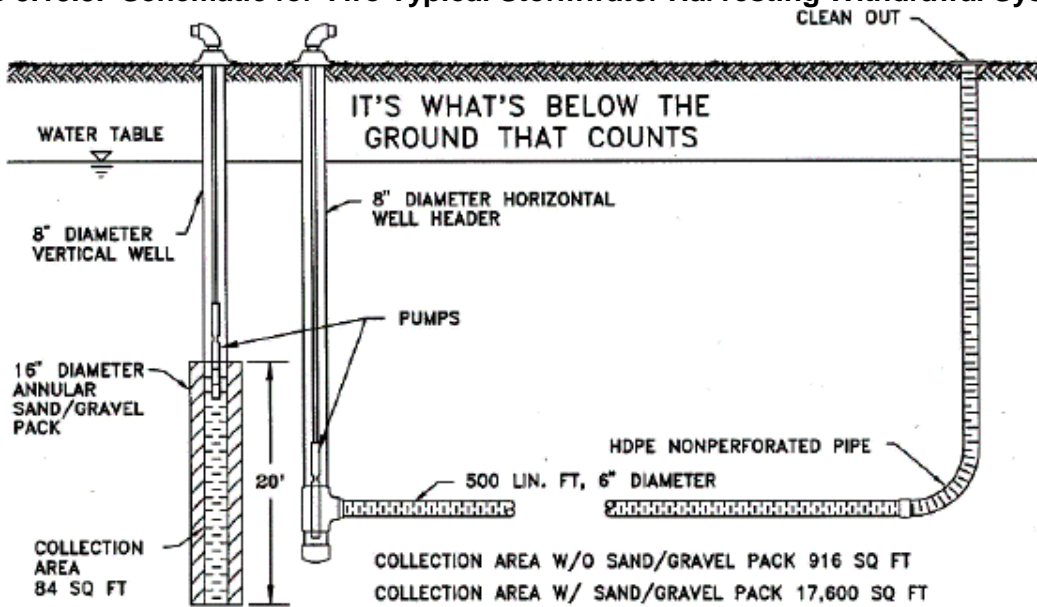

### 5.13.5. Construction requirements

Stormwater harvesting systems typically are used in conjunction with wet detention basins. Therefore, the first step in constructing a stormwater harvesting system is to construct the wet detention basin in compliance with all permitted design specifications. To assure proper construction of the stormwater harvesting system the following construction procedures are required:

1. Construct the wet detention basins following the requirements in [Section 6.12.6](#) of this Manual.
2. Construct the stormwater harvesting system and the associated irrigation system in accordance with all permitted design specifications and irrigation system design standards.
3. Assure that all irrigation components are properly sited and that irrigation spray heads are working properly and not spraying irrigation water onto impervious areas.

### 5.13.6. Inspections, Operation and Maintenance

Maintenance issues associated with stormwater harvesting systems are related to the proper functioning of the horizontal well or filter system and of the pump and irrigation system. Stormwater harvesting systems must be inspected regularly by the operation and maintenance entity to determine if it is operating as designed and permitted. Reports documenting the results of annual inspections shall be filed with the County every two years.

#### 1. Inspection Items:

- Inspect operation of the stormwater harvesting system to assure that the pump, flow meter, and filter system are operating properly and achieving desired flow volumes.
- Inspect the operation of the stormwater harvesting system to assure proper operational and, with respect to the irrigation system, inspect the pump, timer, distribution lines, and sprinkler heads to assure they are working properly.

#### 2. Maintenance Activities As-Needed To Prolong Service:

- Repair any components of the stormwater harvesting system which are not functioning properly and restore proper flow and filtration of stormwater.
- Repair or replace any damaged components of the stormwater harvesting and irrigation system as needed for proper operation.

#### 3. Record keeping

The owner/operator of a stormwater harvesting system must keep a maintenance log of activities that is available at any time for inspection or recertification purposes. The log will include records related to the operation of the stormwater harvesting system and the use of the harvested stormwater for irrigation or other approved purposes to demonstrate that the permitted nutrient load reduction is being achieved. A totalizing flow meter to measure the quantity and day/time of pumping and irrigation is required. The maintenance log shall include the following:

- Stormwater volume harvested using a flow meter specifying the day, time, and volume;
- Stormwater volume irrigated or otherwise used using a flow meter specifying the day, time, and volume used;

- Observations of the stormwater harvesting system operation, maintenance, and a list of parts that were replaced;
- Observations of the irrigation system operation, maintenance, and a list of parts that were replaced; and
- Dates on which the stormwater harvesting and irrigation (or other use systems) were inspected and maintenance activities conducted.

### 5.13.7. Rate-Efficiency-Volume (REV) Curves

The REV curves relate the use rate ( $R$ ), the yearly discharge volume average efficiency ( $E$ ), and the runoff storage volume ( $V$ ) of the pond. The curves reflect several use efficiencies and track the appropriate combinations of use rates and runoff storage volumes to attain the average annual effectiveness. Information concerning any two of these three variables is necessary for the determination of the third. To calculate the average annual effectiveness by simulating the operation of the harvesting pond, the water available for harvesting (irrigation) cannot exceed the runoff storage volume ( $V$ ) plus a one foot decrease in the permanent pool. The reason for this limitation is based on the protection of the vegetation surrounding the pond itself. This also results in a need for supplemental water for irrigation and planning for it must be included in the design.

The REV curves are generalized for application to watersheds of any size and runoff coefficient via the  $EIA$ . The units of both the proposed use rate and runoff storage volume are based on the  $EIA$ . The proposed use rate is the depth of use multiplied by an area, thus it is a volume term.

An individual REV chart is specific to the five meteorological regions of the State used in this Manual. The designer shall use the REV chart closest to the project site and within the meteorological zone for design. Each REV chart is composed of REV curves and each curve is specific for an average annual effectiveness. The REV chart for Alachua County is shown on Figure 6.13.4.

On every REV chart there is a curve for each of the following efficiency levels (in percentage): 20, 30, 40, 50, 60, 70, 80, and 90. Extrapolation between effectiveness lines for a given runoff storage volume on a linear basis is considered reasonable. The range of the curves is restricted by practical applicability and the limits of the simulation variables. The boundaries of the daily data simulation are such that the use rate is limited to no more than 0.50 inches per day over the  $EIA$  and the runoff storage volumes are no less than 0.25 inches and no greater than 6 inches over the  $EIA$ . There are marginal returns on efficiencies beyond some maximum runoff storage volume, thus the curves are only produced where there is a marginal change in effectiveness that is within the measurement accuracy. As an example, at low average annual effectiveness, say 20%, the effectiveness does not change with added runoff storage volume greater than about 2.5 inches. ([M.P. Wanielista, Y.Yousef, G. Harper, L. Dansereau, 1991](#))

Figure 5.13.4. REV Curve for Alachua County

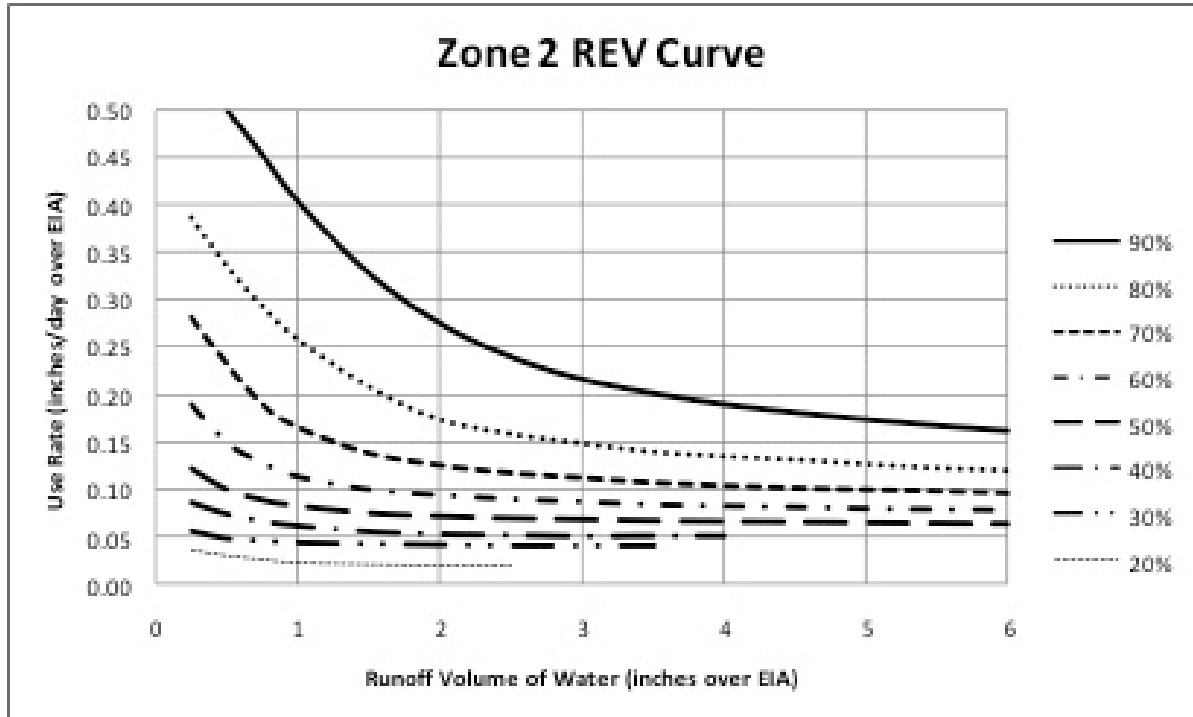

## 5.14. Filter Systems

There are two general types of filters in this Manual: Up-Flow Filters and Down-Flow Filters. Both can be use conventional filtration media or Biofilters (Biofiltration Systems). A Biofilter is used to reduce both particulate and dissolved concentrations of pollutants. Up-Flow Filters are used to “polish off” or reduce concentrations of pollutants discharging to stormwater conveyance systems or surface waters. These are commonly used after wet detention ponds and after pre-treatment BMPs in ultra-urban watersheds. Biofilters are Down-Flow Filters that usually incorporate “engineered media” such as BAM or other soil augmentations to reduce the concentration of pollutants discharged to an under-drain or to the ground water. They are used beneath retention BMPs such as basins, rain gardens, swales, non-paved shoulder areas, planter boxes, exfiltration systems, pervious pavements, and tree wells. These are discussed in more detail in [Section 5.16](#). However, the filter media used for Up-Flow filters are discussed in this section of the Manual.

### 5.14.1. Description

Up-flow filters are used to “polish” treated stormwater by further reducing the pollutant concentrations and therefore the discharged loads. They are commonly used after wet detention systems and pre-treatment BMPs in ultra-urban watersheds (Figures 5.14.1). These pre-treatment BMPs also help to reduce solids and debris. As the name implies, stormwater enters the bottom of these filters and exits from the top. The value of this flow direction is the filter has a lower potential to plug with debris and particulates.

Up-flow filters are very suitable and applicable to ultra-urban development applications because of their capability to remove significant levels of sediments, particulate-bound pollutants (metals, phosphorus and nitrogen) and organics (oil and grease). They are amenable to ultra-urban constraints such as linear configurations and underground installations.

The up-flow filter contains media to remove sediment and both particulate and dissolved pollutants. Using a sorption media in the filter increases the removal of dissolved pollutants. There are two categories for up-flow media filtration defined in this Manual, namely:

- Sand filter systems, and
- Mixed media systems.

A sand up-flow filter is composed of graded sand and is usually two or three feet deep. The sand media removes most particulates of a certain size. Locally available sandy media are preferred but some designs specify the sand particle-size distribution. A summary of early designs and performance is available in a government fact sheet (EPA, 2008). Normally, the sand particle-size distribution is not difficult to achieve, however the cost typically is higher relative to using naturally occurring sands. Example areas where sand filters are used, regulated and recommended for use are California (Caltrans, 2004), Austin Texas (2012), Massachusetts (Mass Highway, 2004), and Delaware ([www.deldot.gov](http://www.deldot.gov)). Sand filters are not effective in removing dissolved nutrients, especially nitrate nitrogen.

For mixed-media up-flow filters, there are at least two different types of media that when used together achieve specified pollutant removal effectiveness. Media mixtures that are effective for removing a wide range of pollutant types are sand/clay with other additions (Woelkers et al., 2006), and expanded clay with other media (Ryan et al., 2009, Hardin et al., 2012). Some mixes target specific pollutants, such as used by the Washington State DOT whose mix targets dissolved metals (WSDOT, 2008), and media mixes that target phosphorus (Ma et al., 2009),



nitrate (Kim et al., 2003), phosphorus and nitrogen (O’Reilly et al., 2012), organics (Milesi et al., 2006), and metals and dioxins (Pitt and Clark, 2010). Thus, a wide selection of media mixtures can be used for media filtration systems (Chang et al., 2010).

Most mixed media can treat stormwater, wastewater, ground water, landfill leachate, and sources of drinking water for nutrient removal via physicochemical and microbiological processes (Chang et al., 2010). The media may include, but are not limited to, compost, clay, zeolite, activated carbon, wheat straw, newspaper, sand, limestone, expanded clay, wood chips, wood fibers, mulch, pumice, bentonite, tire crumb, expanded shale, oyster shell, coconut coir, and soy meal hull (Wanielista and Chang, 2008). A document, entitled *Alternative Stormwater Sorption Media for the Control of Nutrients*, reviews recycled and natural media as prepared for use by the SWFWMD and is available online at:

<http://stormwater.ucf.edu/wp-content/uploads/2014/09/AlternativeMedia2008.pdf>

**UP-FLOW FILTER SYSTEM SUMMARY**

Advantages/Benefits	Used to increase the treatment effectiveness of wet detention systems; applicable to ultra-urban developments and constraints such as linear configurations or underground installations.
Disadvantages/Limitations	Filter system needs regular inspection and maintenance to avoid clogging and ensure continued operation.
Volume Reduction Potential	Low
Pollutant Removal Potential	Moderate for all pollutants
Key design considerations	Use at the discharge end of a detention system; must have flow diverter for high flows to bypass system; typical design filtration rate of 0.02 to 1.0 gallons per minute/square feet (gpm/SF); filtration media mixes available for different pollutants; at least 30” deep filter system; must have a residual moisture content for anoxic conditions to remove nitrogen; schedule for the replacement of filter media must be specified.

**5.14.2. Treatment required**

The required nutrient load reduction will be determined by type of water body to which the stormwater system discharges and the associated performance standard as set forth in [Section 4.3](#) of this Manual. The Up-Flow Filter will be used as part of a BMP Treatment Train, often with a wet detention system.

Figure 5.14.1a. Off-line Up-Flow Filter Schematic

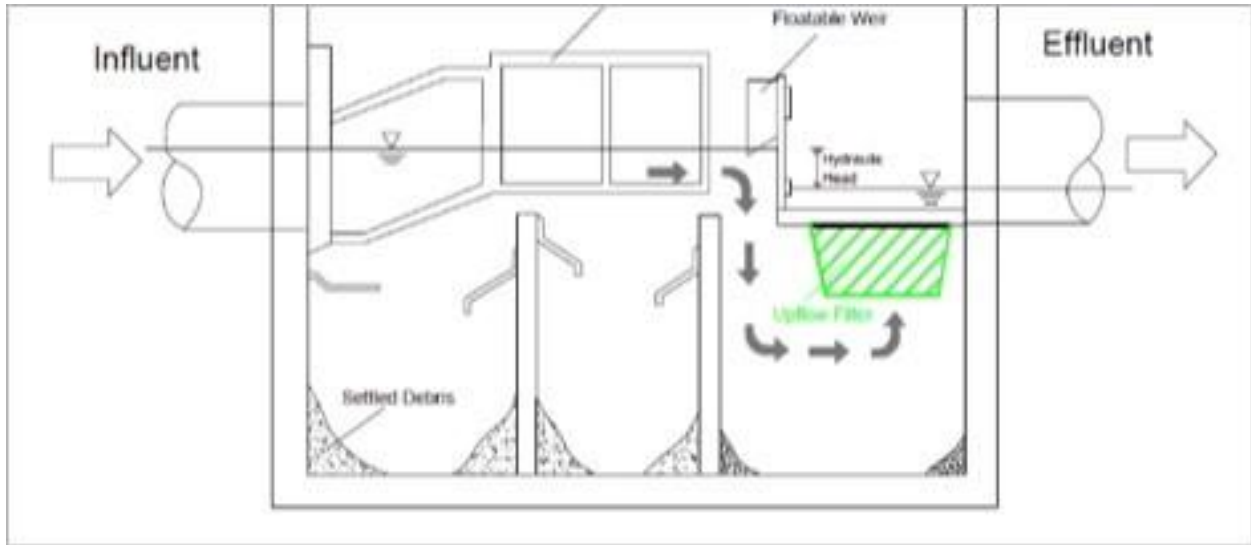
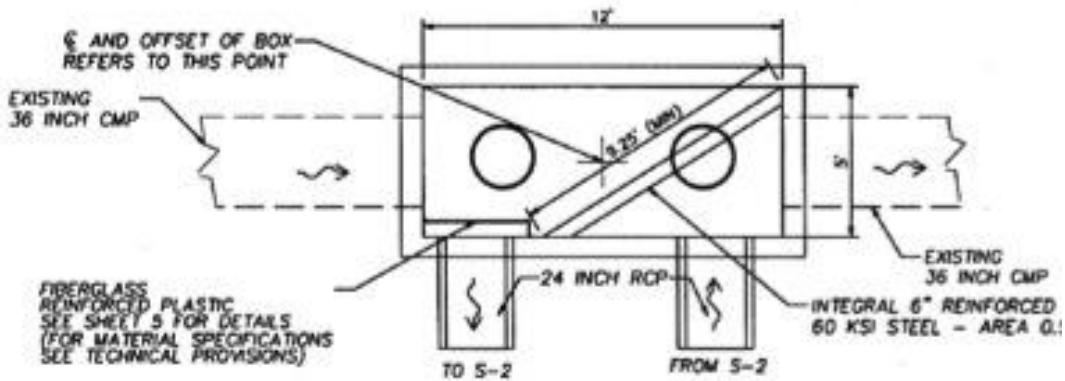

Figure 5.14.1b. Top View of Diversion Box to Off-Line Filter



### 5.14.3. Expected Load Reduction

The expected pollutant load reduction from an Up-Flow Filter System is dependent on the volume of water directed through the filter and the media within the filter. The designer must specify each design parameter and the treatment effectiveness can be determined using the BMPTRAINS program if the media is approved for use by the regulatory agency.

The volume of water treated is expressed as inches captured over the watershed. The inches captured is used to determine the average annual removal capture volume for the meteorological zone in which the project is located as well as the watershed runoff characteristics. Select the treatment volume and then use [Table B2-1](#) to determine the annual percentage of stormwater that is captured.

However, unlike retention systems that provide full pollutant load reduction for the treatment volume being infiltrated, filter media only remove a fraction of the nitrogen and phosphorus. The fraction on nutrients removed is showed for five most frequently used media in [Table 5.14.1](#).

When the up-flow filter is bypassed, the stormwater treatment is equal to the effectiveness of the vault or the wet detention pond. When stormwater flows through the up-flow filter the removal is calculated considering a treatment train approach. Removal is the sum of the first treatment (vault or wet detention pond) plus the removal from the filter. The up-flow filter percent load reduction of Table 5.14.1 is applied to the nutrient concentrations remaining after the vault or wet pond effectiveness.

To illustrate the value of the Up-Flow Filter System media for increasing TN and TP removal, consider the following example. A wet detention system is designed for an annual average residence time of 21 days. The effectiveness of the wet pond for TN removal is 36.2% and TP is 61.5% (see [Figures 5.12.2](#) and [5.12.3](#)). As an example, adding an up-flow filter with B&G ECT3 filter media provides 45% additional removal of TN and TP during filter operation (Table 5.14.1). In this example, 1.5 inches of the water in the wet detention pond (treatment volume in this case) is directed through the up-flow filter, resulting in the annual TN and TP treatment effectiveness of the filter and the wet pond increasing to 61% and 80% respectively. Note that rainfall and watershed conditions will affect the percent removal and the use of BMPTRAINS is recommend to conduct the calculations.

#### 5.14.4. Design Criteria

1. Use of the Up-Flow Filter system after wet detention or after a vault at the end of pipe must include a provision to bypass stormwater when the flow exceeds the filter treatment rate. The filter treatment rate is expressed as inches over the watershed. The percentage of bypass is used to calculate the annual effectiveness. The BMPTRAINS model can be used for this calculation.
2. Use a diversion structure (Figure 5.14.1b) to direct the treatment volume into the Up-Flow Filter and to bypass higher flows into a downstream conveyance system.
3. The design rate of filtration for up-flow filters is typically 1 gpm/SF or about 100-inches/hour because of cost and space constraints. Slower rates can be used especially if effectiveness increases. [Table 5.14.1](#) shows the filtration rates in common use and those necessary to achieve the desired effectiveness when using the media in the table. Additional details for design rates are found in Wanielista, et. al. (2014) that is online at: [http://www.dot.state.fl.us/research-center/Completed\\_Proj/Summary\\_RD/FDOT-BDK78-977-19-rpt.pdf](http://www.dot.state.fl.us/research-center/Completed_Proj/Summary_RD/FDOT-BDK78-977-19-rpt.pdf). Also when using the BMPTRAINS model, user defined media data may be entered into the program.
4. The depth of an up-flow filter is at least 30 inches. This depth typically allows for the residence time necessary to remove nutrients. **For nitrogen removal, the up-flow filter must retain a residual moisture content of at least 0.20 but the media does not need to be replaced. A wet condition is not necessary if phosphorus removal is only needed.**
5. **For phosphorus removal** using the media of Table 5.14.1, the design rate of ortho-phosphate (OP) removal is 0.25 mg of OP/gram of media. This rate is used to determine the replacement or maintenance time for the filter. **Typically, maintenance or replacement times are set at greater than 2 years.** Even though particulate matter is removed by the Up-Flow Filter most of the particulate matter is removed by sedimentation in the pre-treatment area of a vault or within the wet detention pond.

#### 5.14.5. Filter Media for Up-Flow Filters and Biofiltration Systems

1. Up-Flow Filter Media

- A. A typical schematic of an Up-Flow Filter system used at the discharge of a wet detention system or detention vault are shown in Figures 5.14.1a and 5.14.1b. Table 5.14.1 lists four of the more commonly used [BAM](#) filter media. The color of the circles represent the location of the filter in relationship to other components of the BMP Treatment Train. The darker circle represents where the filter is located in the BMP treatment train.
  - B. The B&G ETC up-flow filter media is used after storage in a vault at the end of a pipe. The effectiveness assumes that there is an annual residence time of at least 15 minutes and a screening for debris before the up-flow filter. The B&G ETC up-flow filter media is used after a wet detention pond designed for an annual residence time of at least 21 days. The Austin Texas Sand Filter (SAT) is primarily used in down-flow filters but it can be used in an up-flow filter.
  - C. **To develop new BAM mixtures for up-flow filters, the following specifications need to be met.** The mix must have a residual moisture holding capacity of at least 20%. Water holding capacity must be at least 30%, as measured by fillable porosity. The permeability is less than 2.0 gallon per minute per square foot (gpm/SF) of new clean filter media measured at a static head of 6 inches. For design flow conditions, the rate is reduced by a safety factor to 1.0 gpm/SF. Other options must be submitted with monitoring results to the regulatory agency.
2. Filter Media for Retention BMPs
    - A. The design is based on the concentration removal required to protect the ground water as required by Section 4.3.4. To minimize costs, it is recommended that retention systems be designed as off-line BMPs thereby minimizing the stormwater volume that must be treated annually. The volume captured for treatment, however, has a fraction of the ground water now in use around the State and pioneered in Marion County is the CTS media shown in the last two rows of Table 5.14.1. There are presently two depths for the media with the deeper depth providing a higher treatment effectiveness as shown below. Other media may be used as justified and can be evaluated using the BMPTRAINS model. Since this is a biological process, the media does not need to be replaced. The Marion County media (CTS in Table 5.14.1) has been used for retention BMPs where there is a need to protect ground water from nutrients infiltrating into the ground water.
    - B. **For BAM mixtures for use in the bottom of retention BMPs, the following specifications must be met:** BAM shall be manufactured with mineral materials and no organics. The final product will have more than 2% but less than 6 % passing the 200 sieve and be poorly graded. The mix will be composed of 85% poorly graded sand and 15% sorption materials by volume. The sorption materials are composed of recycled tire with no metals, and naturally occurring clay. The mix will have an average dry weight of non-compacted media greater than 70 pounds per cubic foot. The material will have a water holding capacity of at least 25% as measured by porosity. The permeability as measured in the laboratory must be greater than 2 inches per hour at maximum compaction. For design flow conditions, the rate is 1 inch/hour.
    - C. For all BAM materials, the mix must be non-flammable up to 482° F (250° C). Water passing through the media must not exhibit acute or chronic toxicity and not change the pH of the filtered water by more than 1.0 units. The approved supplier will provide certification of authenticity on composition and performance. Other formulations must be submitted with monitoring results to the regulatory agency.

**5.14.6. Construction considerations**

For all filter media, the media is placed as specified in the plans. The depth and over-burden must be measured and reported in as-built plans. Control devices for diversion of the treatment volume must be maintained and certified on a two-year basis as operational or as specified in the permit documents.

Typical components of an Up-Flow Filter system are detention systems, collection and filtration structures, pretreatment areas to remove gross solids, the media filtration bed itself, effluent collection systems and discharge structures to downstream conveyances or surface water outfalls.

There is no special construction equipment needed other than that commonly used for setting stormwater pipes and excavation. As for any stormwater system, elevation control is needed to establish both the inlet and outlet invert elevations.

Up-Flow Filters typically are used in conjunction with wet detention basins or vaults. Therefore, the first step in constructing an up-flow filter is to construct the wet detention basin or vault in compliance with all permitted design specifications. To assure proper construction of the up-flow filter the following construction procedures are required:





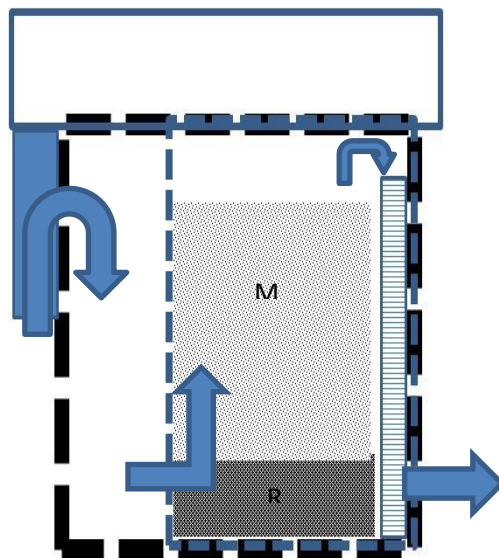

- Construct the wet detention basins or vaults following the requirements in [Section 6.12.6](#) of this Manual.
- Construct the up-flow filter in accordance with all permitted design specifications and the design criteria of this Manual.

A typical schematic of an Up-Flow Filter used at the discharge end of wet detention pond is shown in Figure 5.14.2. A typical schematic of an Up-Flow Filter used at the discharge end of a detention vault is shown in [Figure 5.14.1a](#).

**Figure 5.14.2. Typical Schematic of an Up-flow Filter after Wet Detention with Water Flow Direction Shown**



**Table 5.14.1. Filter Media and Removal Effectiveness.**

DESCRIPTION OF MEDIA	MATERIAL	PROJECTED TREATMENT PERFORMANCE *			TYPICAL OPERATING LIMITING FILTRATION RATE (in/hr)
		TSS REMOVAL EFFICIENCY	TN REMOVAL EFFICIENCY	TP REMOVAL** EFFICIENCY	
 B&G ECT <sup>(ref A)</sup> A first BMP, ex. Up-Flow Filter in Baffle box and a constructed wetland <sup>d</sup> (USER DEFINED BMP)	Expanded Clay <sup>2</sup> Tire Chips <sup>1</sup>	70%	55%	65%	96 in/hr
 B&G OTE <sup>(ref A,B)</sup> Up-flow Filter at Wet Pond or Dry Basin Outflow (FILTRATION)	Organics <sup>8</sup> Tire Chips <sup>1</sup> Expanded Clay <sup>4</sup>	60%	45%	45%	96 in/hr
 B&G ECT3 <sup>(ref C)</sup> After Wet Detention using Up-flow Filter	Expanded Clay <sup>4</sup> Tire Chip <sup>1</sup>	60%	45%	45%	96 in/hr
 SAT <sup>(ref D)</sup> A first BMP, as a Dow n-flow Filter (FILTRATION)	Sand <sup>3</sup>	85%	30%	45%	2 in/hr
 B&G CTS <sup>(ref E,F)</sup> Dow n-Flow Filters 12" depth*** at wet pond or dry basin pervious pave, tree well, rain garden, swale, and strips	Clay <sup>6</sup> Tire Crumb <sup>5</sup> Sand <sup>7</sup> & Topsoil <sup>9</sup>	90%	60%	90%	1.0 in/hr
 B&G CTS <sup>(ref E,F)</sup> Dow n-Flow Filters 24" depth*** at wet pond or dry basin pervious pave, tree well, rain garden, swale, and strips	Clay <sup>6</sup> Tire Crumb <sup>5</sup> Sand <sup>7</sup> & Topsoil <sup>9</sup>	95%	75%	95%	1.0 in/hr

NOTES <sup>#</sup>No generally accepted BMP at this time. Also can be used as a downstream BMP but the removal must be lowered.  
<sup>\*</sup>All Effectiveness Estimates to nearest 5%; <sup>\*\*</sup>Phosphorus removal has limited life expectancy; <sup>\*\*\*</sup>24" depth has TN and TP removals of 75 & 95%  
 acronyms B&G - BOLD & GOLD; SAT - Sand Austin Tx; ECT- Expanded Clay and Tire; ECT3 Expanded Clay and Tire in Treatment Train  
<sup>1</sup> Tire Chip 3/8" and no measurable metal content (approximate dry density = 730 lbs/CY)  
<sup>2</sup> Expanded Clay 5/8 and 3/8 blend (approximate dry density = 950 lbs/CY)  
<sup>3</sup> Sand ASTM C-33 with no more than 3% passing # 200 sieve (approximate dry density = 2200 lbs/CY)  
<sup>4</sup> Expanded Clay 3/8 in blend (approximate density = 950 lbs/CY)  
<sup>5</sup> Tire Crumb 1-5 mm and no measurable metal content (approximate density = 730 lbs/CY)  
<sup>6</sup> Medium Plasticity typically light colored Clay (approximate density = 2500 lbs/CY)  
<sup>7</sup> Sand with less than 5% passing #200 sieve (approximate density = 2200 lbs/CY)  
<sup>8</sup> Organics: Either compost (approximate density of 700 lbs/CY) Class 1A Compost or wood chips (sawdust) without pesticides  
<sup>9</sup> Local top soil is used over CTS media in drybasins, gardens, swales and strips, is free of roots & debris but is not used in other BMPs.

A - Demonstration Bio Media for Ultra-urban Stormwater Treatment, Wanielista, et.al. FDOT Project BDK78 977-19, 2014  
 B - Nutrient Reduction in a Stormwater Pond Discharge in Florida, Ryan, et al, Water Air Soil Pollution, 2010  
 C - Up-Flow Filtration for Wet Detention Ponds, Wanielista and Flint, Florida Stormwater Association, June 12, 2014.  
 D - City of Austin Environmental Criteria Manual, Section 1.6.5, Texas, 2012  
 E - Nitrogen Transport and Transformation in Retention Basins, Marion Co, Fl, Wanielista, et al, State DEP, 2011  
 F - Improving Nitrogen Efficiencies in Dry Ponds, Williams and Wanielista, Florida Stormwater Association, June 18 2015

**5.14.7. Inspections, Operation and Maintenance**

Because of the location of infiltration filters, there is rarely a need for maintenance. Nevertheless, the infiltration rate must be documented over time and provisions for re-establishing infiltration rates must be in-place. These provisions are usually diking of the surface of the media and cleaning of debris. For on-site locations, replacement of small amounts of filter media may be an option.

For up-flow filters, a pump suction-type evacuator is usually used to remove debris. The same equipment cleans debris and solids from catch basins and sewer lines. In front of a filter, a settling system minimizes solids and debris on the filter. The sedimentation process of the settling system removes heavy solids, debris and floating materials, and reduces the maintenance needed to keep the filter operational. Reports documenting the results of annual inspections shall be filed with the County every two years.



### 1. Inspection Items:

- Inspect operation of the up-flow filter to assure that water is flowing through the filter.
- Inspect the inlet and outlet structures to assure they are working properly and no debris impedes operation.

### 2. Maintenance Activities As-Needed To Prolong Service:

- Repair any components that are not functioning properly and restore proper flow and filtration of stormwater.
- Repair or replace any damaged components as needed for proper operation.
- Replace filter media if it is being used for phosphorus removal.

### 3. Record keeping

The owner/operator of an Up-Flow Filter must keep a maintenance log of activities which is available at any time for inspection or recertification purposes. The log will include records related to the operation and maintenance. The maintenance log shall include the following:

- An estimate of the stormwater volume passing through the filter in a year;
- Inspection dates and forms;
- Maintenance dates and activities including a list of parts that were replaced.

## 5.14.8. References

1. Austin Texas (2012). City of Austin Texas Environmental Criteria Manual. Section 1.6, Austin.
2. Caltrans (2006). Highway 267 Filter Fabric Sand Trap Pilot Study, 2004–2005 Interim Report, California Department of Transportation, CTSW-RT-05-157.01.1.
3. Chang, N., F. Hossain, M. Wanielista (2010). Filter Media for Nutrient Removal in Natural Systems and Built Environments: Previous Trends and Perspectives. Environmental Engineering Sciences, Volume 27, Number 9, pp 689-706.
4. EPA, Environmental Protection Agency (2008). Stormwater Technology Fact Sheet: Sand Filters. Washington D.C. EPA 832-F-99-007, September.
5. Hardin, M., M. Wanielista, and M. Chopra (2012). A Mass Balance Model for Designing Green Roof Systems that Incorporate a Cistern for Re-Use. Water, 4, 1, doi: 10.3390/w40.
6. Kim, H. H., E. A. Seagren, and A. P. Davis (2003). Engineered Bioretention for Removal of Nitrate from Stormwater Runoff, Water Environment Research, 75 (4): 355–367.
7. Ma, J., K. Tracy, and J. Lenhart (2009). Phosphorus Removal in Urban Runoff Using Adsorptive Filtration Media, Proceedings of Storm-Con 2009, August 16–20, Anaheim, CA.
8. MassHighway (2004). Storm Water Handbook for Highways and Bridges, Massachusetts Highway Department.
9. Milesi, C., S. A. de Ridder, D. DeLeon, H. Wachter (2006). A Comparison of Two Media Filtration BMP Treatments for the Removal of PAHs and Phthalates from Roadway Runoff, Proceedings of StormCon 2006. July 24–27, Denver, CO.
10. O'Reilly, A., M. Wanielista, N. Chang, Z. Xuan, and W. Harris (2012). Nutrient removal using biosorption activated media: Preliminary biogeochemical assessment of an innovative stormwater infiltration basin. Journal: Science of the Total Environment. May.
11. Pitt, R. and S. Clark (2010). Evaluation of Biofiltration Media for Engineered Natural Treatment Systems, Department of Civil, Construction and Environmental Engineering, University of Alabama.

12. Ryan, P., M. Wanielista and N. Chang (2009). Nutrient Reduction in Stormwater Pond Discharge Using a Chamber Up-flow Filter and Skimmer (CUFS), Water, Air and Soil Pollution, doi:10.1007/s11270-009-0174-x, Aug.
13. Wanielista, Martin and Ni-Bin Chang (2008). Alternative Stormwater Sorption Media for the Control of Nutrients, Final Report: Project #B236, Southwest Florida Water Management District, Brooksville, Fl.
14. Wanielista, Martin, Ni-Bin Chang, Andrew Randall, Manoj Chopra, Mike Hardin, Jamie Jones, Andrew Hood, and Sultan Salamah (2014). Demonstration Bio Media for Ultra-urban Stormwater Treatment, Florida Department of Transportation, Tallahassee, Fl.
15. Williams, Shane and Martin Wanielista (2015). Improved Nitrogen Efficiencies in Dry Ponds, Florida Stormwater Association Annual Meeting, June 18.
16. WSDOT (2008). Washington State Department of Transportation Highway Runoff Manual, M 31-16.01, Environmental and Engineering Programs Design Office.

## 5.15. Managed Aquatic Plant System (MAPS) Design Criteria

### 5.15.1. Description

Managed Aquatic Plant Systems (MAPS) are aquatic plant-based BMPs that remove nutrients through a variety of processes related to nutrient uptake, transformation, and microbial activities. Examples of MAPS include planted littoral zones and floating wetland mats. In the latter example, harvesting of the biomass is an essential process of the BMP.

Generally, wet detention systems by themselves can't achieve the required levels of nutrient removal from stormwater. In nearly all cases, a BMP treatment train will be required when using a wet detention system. Sometimes components of the BMP treatment train include source controls or pretreatment BMPs such as retention or swales to reduce either the stormwater volume or nutrient concentrations in stormwater discharged to the wet detention system. However, in many areas, high water tables and slowly percolating soils do not make infiltration practices practical or effective. Managed Aquatic Plant Systems (MAPS) can be incorporated into a wet detention BMP treatment train to provide additional treatment and nutrient removal after the wet pond has provided reduction of pollutants through settling and other mechanisms that occur within the wet pond.

#### MANAGED AQUATIC PLANT SYSTEM SUMMARY

Advantages/Benefits	Increases the treatment effectiveness of wet detention systems, especially for nutrients; increases the aesthetics and habitat quality of wet detention systems.
Disadvantages/Limitations	Increases maintenance requirements of wet detention systems; water level fluctuation in wet detention systems often reduces growth of littoral zone plants.
Volume Reduction Potential	None
Pollutant Removal Potential	Low for all pollutants
Key design considerations	Determine if littoral zone or floating wetland mats will be used; for littoral zones ensure proper slopes and surface water elevations; determine plant species and planting densities to achieve the required areal extent and plant coverage; for floating wetland mats, determine plant species and preferred location for mats; also determine if exclusion netting is needed to protect plants from herbivores.
Key construction and maintenance considerations	Inspect to ensure plant survival and coverage meet permit requirements and replant as needed; identify nuisance or exotic plants and remove; harvest and replace plants in floating mats on an annual basis.

**5.15.2. Nutrient Removal Effectiveness and Credits**

Table 5.15.1 summarizes the nutrient reduction credits based on the data that are currently available. It is anticipated that more data will become available in the future to better characterize the pollutant load reductions. The nutrient removal credits associated with MAPS shall be calculated using the BMPTRAINS software or the underlying BMP Treatment Train Equations. If an applicant proposes to use a higher level of nutrient load reduction than set in Table 5.15.1, the applicant must provide stormwater treatment nutrient removal effectiveness data to support the higher level of load reduction.

**Table 5.15.1. Nutrient Removal Credits for MAPS**

Type of MAPS	TN Removal	TP Removal
Littoral zone	10%	10%
Floating Wetland Mats or Islands	10%	10%

**5.15.3. Littoral Zone Design Criteria**

Littoral zones are an optional component of wet detention systems. The littoral zone is that portion of a wet detention pond that is designed to contain rooted aquatic plants. Extending and gently sloping the sides of the wet detention system to a maximum depth of four feet below the normal water level or control elevation usually creates the littoral area. One of the difficulties of successful littoral zone establishment and maintenance is the frequent changes in water level elevations within a wet detention pond. Additionally, experience has shown that long term survival of littoral zones is best when they are not located adjacent to private lots. Consequently, littoral zones typically are located near the outfall of a wet detention pond or along areas with common ownership. Littoral zones should also be considered in other areas of the pond that have depths suitable for successful plant growth such as a shallow shelf between the inflow sumps and the rest of the pond or on a shallow shelf in the middle of the pond, provided maintenance can be undertaken. If treatment credit is proposed for littoral zones placed adjacent to private lots, the applicant shall provide additional assurances through their legal operation and maintenance documents or through an easement that the littoral zone will be maintained as permitted.

The littoral zone is established with native plants by planting and/or the placement of wetland soils containing seeds of native plants. A specific vegetation establishment plan must be prepared for the littoral zone. The plan must consider the water elevation fluctuations of the wet detention pond and the ability of specific plants to be established. A list of recommended native plant species suitable for littoral zone planting is included in Table 5.15.2. In addition, a layer of muck soil can be incorporated into the littoral area to promote the establishment of the wetland vegetation. When placing muck, special precautions must be taken to prevent erosion and turbidity problems in the pond and at its discharge point while vegetation is becoming established in the littoral zone.

The following is a list of the design criteria for wet detention littoral zones:

1. The littoral zone shall be gently sloped (6H:1V or flatter). At least 30 percent of the wet detention pond surface area shall consist of a littoral zone. The percentage of littoral zone is

- based on the ratio of vegetated littoral zone to surface area of the pond at the control elevation.
2. The bleeddown volume should not cause the pond level to rise more than 18 inches above the control elevation unless the applicant affirmatively demonstrates that the littoral zone vegetation can survive at greater depths.
  3. Within 24 months of completion of the system, 80 percent coverage of the littoral zone area by suitable aquatic plants is required with no more than 10% consisting of exotic or nuisance species such as cattails or primrose willow.
  4. Planting of the littoral zone is required to meet the 80% coverage requirement. As an alternative to planting, portions of the littoral zone may be established by placement of wetland top soils (at least a four inch depth) containing a seed source of desirable native plants. When using this alternative, the littoral zone must be stabilized by mulching or other means. At least the portion of the littoral zone within 25 feet of the inlet and outlet structures must be planted. In addition, monitoring of plants shall be done quarterly to ensure that the 80% coverage requirement is met within one year.
  5. In parts of Florida, the Channeled Apple Snail has been shown to decimate littoral zone vegetation so designers need to be aware of this problem and will be required to provide additional assurances that damage done to the vegetation will be repaired within one month.
  6. Replanting shall be required if the percentage of vegetative cover falls below the permitted level. The native vegetation within the littoral zone shall be maintained as part of the system's operation and maintenance plan. Undesirable species such as cattail and other exotic or nuisance plants shall be controlled and removed as needed.

**Table 5.15.2. Native Plant Species Suitable for Littoral Zone Plantings or Adjacent to Wet Detention Ponds**

SCIENTIFIC NAME	COMMON NAME	PLANTING ZONE *	FEATURES
<b>FRESHWATER WOODY SPECIES (trees, shrubs, and palms)</b>			
Acer rubrum	Red maple	1-2	Medium sized tree specimen known for its attractive brilliant red fall color
Carpinus caroliniana	American hornbeam "Blue Beech"	1	Medium sized tree with attractive bark, and interesting form.
Carya aquatica	Water hickory	1-2	Large tree with large leaves. Fall color (bright yellow)
Cephalanthus occidentalis	Buttonbush	1-2	Large shrub up to 10 ft tall with white flowers resembling buttons. Buttonbush has a scrubby appearance owing to the dying of leader shoots leaving dead stumps.
Clethra alnifolia	Sweet pepper bush	2	Highlighter, shrub with attractive berries
Crataegus marshallii	parsley hawthorn	1	showy, white flowers and red fruits are good wildlife food
Fraxinus caroliniana	Popash	1-2	Large specimen with attractive foliage and deep furrowed bark

SCIENTIFIC NAME	COMMON NAME	PLANTING ZONE *	FEATURES
Gordonia lasianthus	Loblolly bay	1-2	Medium to large tree. Large white flowers and attractive foliage
Hypericum spp.	St. Johns Wort	2	Highlighter, shrub
Ilex cassine	Dahoon holly	1	Small tree or shrub with prominent red berries and attractive evergreen foliage
Ilex vomitoria	Yaupon	1	General landscape shrub with attractive red berries.
Liquidambar styraciflua	Sweetgum	1-2	Medium to large specimen. Attractive unusual shaped foliage and good fall color. Not tolerant of long term inundation
Magnolia virginiana	Sweet bay	1	Medium sized tree with attractive foliage and white flowers.
Myrica cerifera	Wax myrtle	1	Large shrub with attractive aromatic evergreen foliage. Bluish green berries in autumn and winter are eaten by many birds. Often used in groups for general landscaping and high lighting or accent around ponds.
Nyssa biflora	Blackgum tupelo	1-2	Glossy foliage turning bright red in autumn. Fruit matures in the fall; is consumed by many birds. Flowers are a source for honey.
Persea palustris	Swamp redbay	1-2	Attractive aromatic glossy green foliage. Bitter fruit is eaten by wildlife. Does not do well in submerged locations.
Quercus michauxii	Swamp oak	1	Large rapidly growing tree with attractive nearly evergreen foliage. Acorns eaten by wildlife.
Quercus phellos	Willow oak	1	Large deciduous tree with willow-like leaves. Acorns provide food for wildlife.
Rhapidophyllum hystrix	Needle palm	1	Small to medium sized palm with attractive foliage used for providing tropical highlights. Sharp needles along the trunk lead to its name
Sabal palmetto	Cabbage palm	1	Large palm suited to all areas. Attractive tropical fan shaped foliage.
Taxodium spp.	Bald or Pond Cypress	1-2	Large aquatic deciduous conifer of picturesque form. Preliminary observation shows good survival and rapid growth of either species when



SCIENTIFIC NAME	COMMON NAME	PLANTING ZONE *	FEATURES
			used for stormwater enhancement purposes.
<b><u>FRESHWATER HERBACEOUS SPECIES (herbs, sedges, grasses, and ferns)</u></b>			
Bacopa caroliniana	Lemon bacopa "Water hyssops"	2	Crushed leaves and stems lemon scented. Flowers blue.
Canna flaccida	Golden canna "Canna lily"	2	Very good highlighter. Used on fringe of ponds and lakes. Large showy yellow flowers.
Cladium jamaicense	Saw-grass	1-2	Coarse perennial sedge up to 10 ft. tall. Grows equally well in water or several feet above water level. Long narrow and serrated leaf blades. Provides nesting, protection and food (seeds) for water fowl and other birds.
Coreopsis leavenworthii	Tickseed	2	Perennial herb w/ attractive yellow flowers. Prefers soil at edge of ponds or lakes
Crinum americanum	Swamp lily	2	Good highlighter at pond fringes. Showy white fragrant flowers. Stems usually less than waist high.
Cyperus odoratus	Umbrella sedge	1-2	Good accent plant usually grown in clumps on edge of ponds. Does well in areas of fluctuating water but also in more upland areas. Its stems are usually less than 3 ft. tall with a conspicuous umbrella shaped foliage and brown seed head
Diodia virginiana	Buttonweed	1-2	Does well in wet soils along the border of ponds. Relatively low growing perennial herb. Small white flowers between leaves and stem. Does not prefer submerged conditions.
Dryopteris ludoviciana	Southern shield Leatherleaf fern	1-2	Suited to wet soils in the zone of fluctuation above the permanent pool
Echinochloa crusgalli	Barnyard grass "wild millet"	1-2	Best suited for edges of ponds and lakes. Steps up to 4 ft tall. Seeds used by waterfowl and songbirds
Eleocharis spp.	Spikerushes	1-2	Suitable for establishing marshes along the coast. Slender, dwarf, and water spikerushes may be submerged. Other varieties grow along the landward edge

SCIENTIFIC NAME	COMMON NAME	PLANTING ZONE *	FEATURES
			of ponds. May be grown in clumps or as colonies depending on species
Eriocaulon decangulare	Hat pins	2	Low growing plant with slender spikes. Top is tipped with a small white "button." Provides good contrast with wetland grasses or sedges
Hibiscus spp.	Marsh hibiscus	1-2	Normally used for accent on the edge of ponds. Large flowers 4-8" in diameter.
Hydrocotyle umbellata	Water pennywort	2	Numerous round partly to deeply lobed leaves centrally attached to a stem up to 12 inches long. Grows well on the surface of the water or as a groundcover rooted along the edge of ponds
Hymenocallis spp.	Spider lilies	1-2	Provides good ground cover, used for accent on the edge of ponds. Showy white flowers. Best on wet soils.
Iris virginica	Anglepod blue flag iris	2	Prefers wet soils at the fringes of lakes and ponds. Average height of 1 ft. With blue flowers. Used for highlighting, planted in groups at the edges of wetlands or ponds.
Iris irginicus	Southern blue flag iris	2	Prefers habitats similar to "angelpod." More upright grower. Flowers last for several weeks in spring
Juncus effusus	Soft rush	2	Very attractive with pale green hollow stems up to 4 ft tall. Commonly used in large clumps along the edge of lakes or ponds. Seeds used by waterfowl. Does not die back in winter making it a good plant for wet detention ponds where it is planted in clumps
Nelumbo lutea	American lotus	3-4	Attractive, large leafed rooted aquatic. Circular leaves up to 24 inches across with large showy yellow flowers. Planted along the outside of littoral zones in groups spaced about 25 feet apart
Nuphar luteum	Spatterdock	3-4	Water lily with large oval or heart shaped leaves up to 16 inches long and 10 inches wide. Small, spherically shaped yellow flowers. Roots provide good habitat for shellcrackers.
Nymphaea mexicana	Yellow water lily	3-4	Similar in form and use as other water lilies. Bright yellow flowers.
Nymphoides aquatica	Floating hearts	2-4	Similar to other water lilies. Short thick roots with a cluster of small white flowers

SCIENTIFIC NAME	COMMON NAME	PLANTING ZONE *	FEATURES
Osmunda cinnamomea	Cinnamon fern	2	Attractive lush foliage best suited for shaded areas internal to or approaching the periphery of cypress or other wooded wetlands
Osmunda regalis	Royal fern	2	Similar habitat as cinnamon fern. May be used to add a “rain forest” like appearance.
Panicum hemitomon	Maidencane	1-2	A grass that does well in dry soils or submerged in water. Forms dense colonies in wet areas and shallow parts of ponds. Aggressive grower.
Peltandra virginica	Green Arrow arum		Perennial herb with arrow shaped leaves up to waist high. Blades vary in size up to a foot wide and 1.5 feet long
Polygonum spp.	Smartweed	2	An annual or perennial herb with creeping stems that grows along the ground. Stems have spikes of small pink and white flowers. Seeds used by birds, waterfowl, and small mammals
Pontedaria cordata	Pickereelweed	3	One of the most commonly used and attractive plants in littoral zones. Attractive dark green lance shaped leaves with violet blue flowers.
Sagittaria lancifolia	Arrowhead	3	Another of the more common plants used in littoral zones. Has narrow elliptical lance shaped leaves up to 2 ft in length and 4 inches wide with small white flowers
Sagittaria latifolia	Broadleaf arrowhead	3	Has deeply lobed and arrow shaped leaves up to 1 foot long with small white flowers
Scirpus californicus	Giant bulrush	2-3	Has blunt triangular stems up to 10 ft tall.
Scirpus validus	Soft stem bulrush	2-3	Has cylindrical stems up to 8 feet tall. Attractive brown spikelets with seeds that are eaten by waterfowl and songbirds
Spartina bakeri	Sand cordgrass	1-2	This grass grows in stout and dense clumps. Excellent accent plant on fringes of wet ponds. Has a reddish tinge when flowering.

\* Planting Zones:

- 1) + 0.5 feet or more higher than the normal level of the permanent pool.
- 2) +0.5 feet above to -1.0 feet below normal pool.
- 3) - 1.0 feet to - 3.0 feet below the control elevation of the permanent pool.
- 4) - 3.0 feet to - 5.0 feet below normal water level.

#### 5.15.4. Floating Wetland Islands or Mats

Because plants in the aquatic environment store and concentrate nutrients in their tissues, created wetlands have been used extensively for bioremediation. Most of the treatment of nutrient rich water within a wetland occurs in the thin aerobic layer at the surface of the soils within plant communities. This aerobic biofilm is a result of oxygen leakage from the plant roots at the soil-water interface. Floating wetland mats or islands allow growth of plants that can extract and store nutrients from surface waters. Through the periodic removal of mature macrophytes from the floating wetland island or mat, accumulated nutrients are prevented from re-entering the aquatic ecosystem at senescence.

Floating Wetland Design Criteria:

1. The area of floating wetland mats shall be at least five percent (5%) of the surface area of the wet detention pond.
2. The floating wetland island or mats shall use a variety of plants that have been documented to have high nutrient uptake in their plant tissues. Some proven plants include *Canna flaccida*, *Juncus effuses*, *Spartina spp.*, *Pontederia cordata*,
3. Floating wetland mats or islands shall be installed and maintained in accordance with permitted design specifications and the manufacturer's instructions.
4. Where necessary, exclusion netting shall be used on floating islands or mats to prevent turtles, grass carp, or other animals from eating the plant roots or plants such that they adversely affect the successful growth of the aquatic plants. The applicant may propose alternative mechanisms to minimize eating of plant roots or plants based on an affirmative demonstration, based on manufacturer's recommendations, plans, test results, calculations or other information, that the alternative design is appropriate for the specific site conditions and will meet the above considerations.
5. Within 6 months of installation, the floating wetland island or mat shall have at least 90 percent coverage with no more than 10% consisting of exotic or nuisance species.
6. Plants on the mats or islands shall be removed and replaced at a minimum on an annual basis. The harvested plant and potting materials shall be removed and disposed of in such a manner that nutrients will not re-enter the stormwater treatment system.

## 5.16. Biofiltration Systems

### 5.16.1. Description

Biofilters or biofiltration systems are a suite of typically off-line BMPs that use engineered media, such as [Biosorption Activated Media \(BAM\)](#), to enhance nutrient removal when native soils can't provide adequate pollutant removal or infiltration. They also are used when soils do not have an adequate infiltration rate for retention systems. They are used in [Sensitive Karst Areas](#) to remove nitrates where the sandy soils and infiltration rates allow nitrate movement into the ground water. They can serve both small and large watersheds. The large watersheds typically discharge into retention basins or wet detention systems. The wet detention systems will then use up-flow filters on the discharge to further remove nutrients, especially the nitrate form of nitrogen. Small drainage areas discharge into depression areas or rain gardens that have BAM within them. Typically, these are either off-line retention BMPs or online stormwater detention BMPs that serve small drainage areas of up to two acres.

Biofiltration systems with BAM incorporate select soils, cellulose, or other pollutant removal mixtures. For the removal of phosphorus, BAM must have a sorption capacity for phosphorus. For nitrate removal, other properties of the containment should be present such as an anoxic zone. Planted vegetation to facilitate treatment for removal of nutrients is common. The use of BAM will also reduce toxic compounds in the discharge waters.

There are many opportunities for biofiltration systems and many configurations making them highly applicable for on-site treatment in urban development, especially in areas undergoing redevelopment. They can have an underdrain for surface water discharge but also can be designed to function as retention systems. Examples include;

- Shallow depressed areas within the landscaping
- Landscape planter boxes
- Tree box filters

Planter boxes and tree box filters are discussed in more depth in [Section 5.16.8](#) and [5.16.9](#).

The biofiltration system may be lined to keep it separate from the surrounding water table and to maintain an anoxic zone in the bottom of the system that promotes the Nitrogen Cycle (see [Figure 2.3](#)). Separating the biofiltration system from the water table allows biofiltration systems to be used where the [SHGWT](#) is within two feet of land surfaces and has several advantages:

- an anoxic zone is created to facilitate improved nitrogen removal.
- if a permanently wet zone is used, it serves as a source of water for plants within the biofiltration system. The plant root zone must be able to tolerate being wet most of the time. Some BAM mixes retain a residual moisture content and do not have to be resident in a permanently wet zone.
- the underdrain system is not permitted to drain ground water, which can contribute significant nutrient loads to the surface water system. This allows biofiltration systems to be used where the SHGWT table is within two feet of land surface.
- the system can be used where there may be concerns about contamination of ground water.
- the system can be used adjacent to structures that may be adversely impacted by ground water, such as building foundations and road foundations.

The major components of a biofiltration system include:

- Pretreatment area (optional) – sediment and trash pre-treatment vegetated buffers, or swales are commonly used (See [Appendix C](#) for sizing sediment sumps).
- Ponding area – typically limited to a depth of 6 to 12 inches
- Groundcover layer and plants – typically 2 to 6 inches of top soil planted with Florida-friendly plants.
- Media – Varies depending on purpose (porosity and filtration)
- Surface inlet and outlet controls – non-erosive inflows and underdrain outflow

As is customary with LID principles, numerous biofiltration systems distributed throughout a catchment instead of a single large stormwater basin or pond help facilitate treatment near the source. Although any one treatment area may be small, the cumulative effect of multiple systems can be significant.

**BIOFILTRATION SYSTEM SUMMARY**

Advantages/Benefits	Applicable to small drainage areas; applicable to high SHGWT conditions; applicable to Sensitive Karst Areas to limit nitrate movement to the ground water; applicable to highly urban areas with land limitations; can be designed as an aesthetic amenity.
Disadvantages/Limitations	May require an underdrain system, filter media mixture, and landscaping.
Volume Reduction Potential	Low, not a flood control BMP.
Pollutant Removal Potential	Moderate to significant for most pollutants depending on media mixture.
Key design considerations	Contributing drainage area usually under 2 acres; separate from SHGWT by structural methods to reduce nitrates; at least 2 inches of top soil, appropriate depth of planting soil, and 24 inches of filter media with a carbon source for nitrate removal; must be able to discharge into an appropriate conveyance system or the ground water.
Key construction and maintenance considerations	Inspect inflow/outflow points for any clogging; inspect pre-treatment BMPs for clogging; inspect prefilter strip vegetated buffer/grass swale and ponding area for erosion or gully; inspect trees and shrubs to evaluate their health; inspect the underdrain system to ensure it is not clogged; test planting soil pH every 3 years to ensure between 5.5 and 6.5; if infiltration based, test infiltration rate with double ring infiltrometer or other devices approved by the regulatory agency every 3 years. If media is used for phosphorus removal, it must be replaced periodically.



### 5.16.2. Biosorption Activated Media (BAM)

As the use of LID BMPs such as biofiltration became more widespread, the need to develop and evaluate engineered media that were effective in removing stormwater pollutants grew. Over the past decade numerous research projects on BAM have been conducted. Leadership on this research originated in the mid-Atlantic states, the Pacific Northwest, the University of Minnesota, Monash University in New Zealand, University of Florida, and at the UCF Stormwater Management Academy. The objective of this research is to conduct material characterization of different types of sorption media that are functionalized for nutrient removal. The term sorption media is used as a qualifier for the media because the pollutant removal is by surface bonding to the media or incorporation within the media. A sorption media that is formulated and tested for specific pollutant removal in a specific stormwater installation is designated as a functionalized sorption media. To predict the nutrient removal value, mathematical equations for nutrient removal chemical means (called Langmuir and Freundlich isotherms) are used. Additional removal may result from biological means including organisms and plants. Particulate matter may be removed from the stormwater by filtration when water is passed through the media.

Sorption media with mixes containing recycled materials, such as cellulose and tire crumb, combined with natural soils such as sand/silt/clay and limestone, are recommended for nutrient removal in stormwater management systems, including filters and retention BMPs. Media for biofilters are targeted at removing a wide range of pollutants from nutrients to heavy metals. Some media for use in retention BMPs are targeted at facilitating the Nitrogen Cycle to minimize the production of nitrates and nitrate loading to the ground water. [Table 5.14.1](#) contains a list of BAM filter media and [Section 5.14.5](#) discusses the use of these media.

Since the water quality focus in Florida is on reducing nutrient loadings to surface and ground waters, the stormwater designer is referred to the publication entitled “Alternative Stormwater Sorption Media for the Control of Nutrients” prepared by the UCF Stormwater Management Academy for the SWFWMD. This publication is available online at:

<http://stormwater.ucf.edu/wp-content/uploads/2014/09/AlternativeMedia2008.pdf>

### 5.16.3. Applicability

#### 1. Water quantity control

Biofiltration systems are designed primarily as BMPs for addressing stormwater quality. Although biofiltration systems will provide some attenuation of peak flows, they will most likely not provide sufficient storage capacity to meet County or applicable WMD water quantity control criteria.

#### 2. Water quality control

Biofiltration systems use the chemical, biological, and physical properties of plants, microbes, and soils or engineered media (BAM) to remove stormwater pollutants. Biofilters may be especially useful in highly urban areas where land for retention or wet detention systems is scarce and soils are inappropriate for retention systems. For example, roof runoff can be effectively detained and treated in a containerized biofilters such as a planter box. Parking lot runoff can be routed into shallow depressed landscape island rain gardens using curb cuts or into biofilters integrated into the landscaping adjacent to the parking lot. Figures 5.16.1 through 5.16.6 provide illustrations of the several types of biofiltration systems with underdrains. Each

of these systems can be installed without an underdrain if the soils will permit infiltration of the treatment volume.

Figure 5.16.1. Plan View Illustrating a Biofiltration System



Figure 5.16.2. Cross Section View of a Biofiltration System

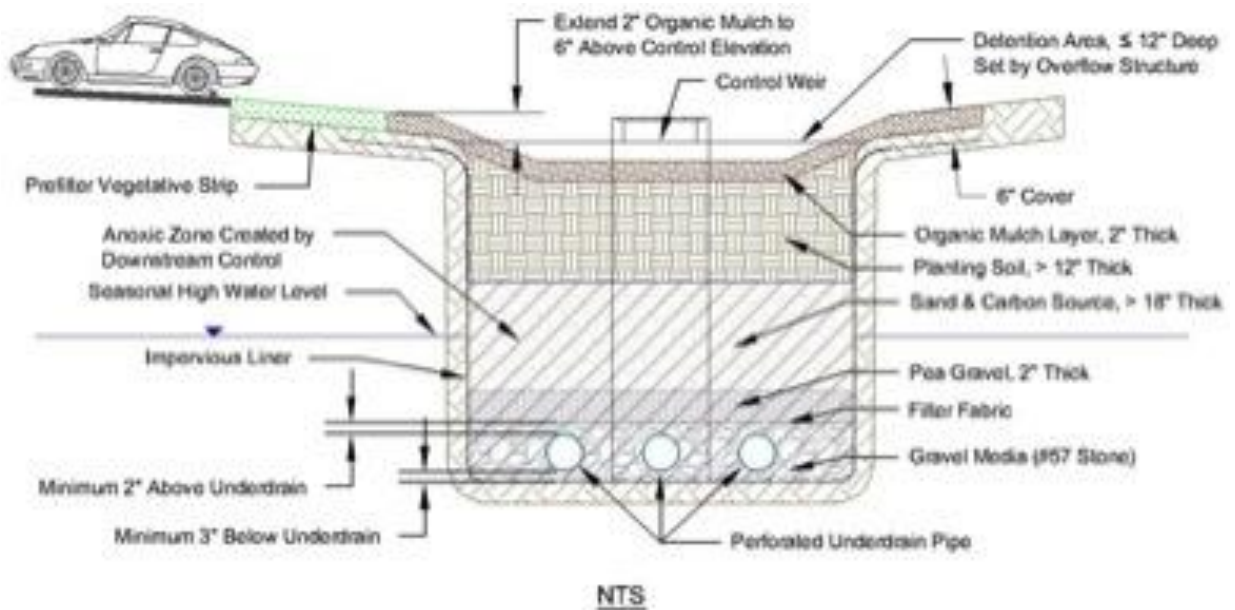

Figure 5.16.3. Example Cross Section View for Nitrate Removal with Overflow

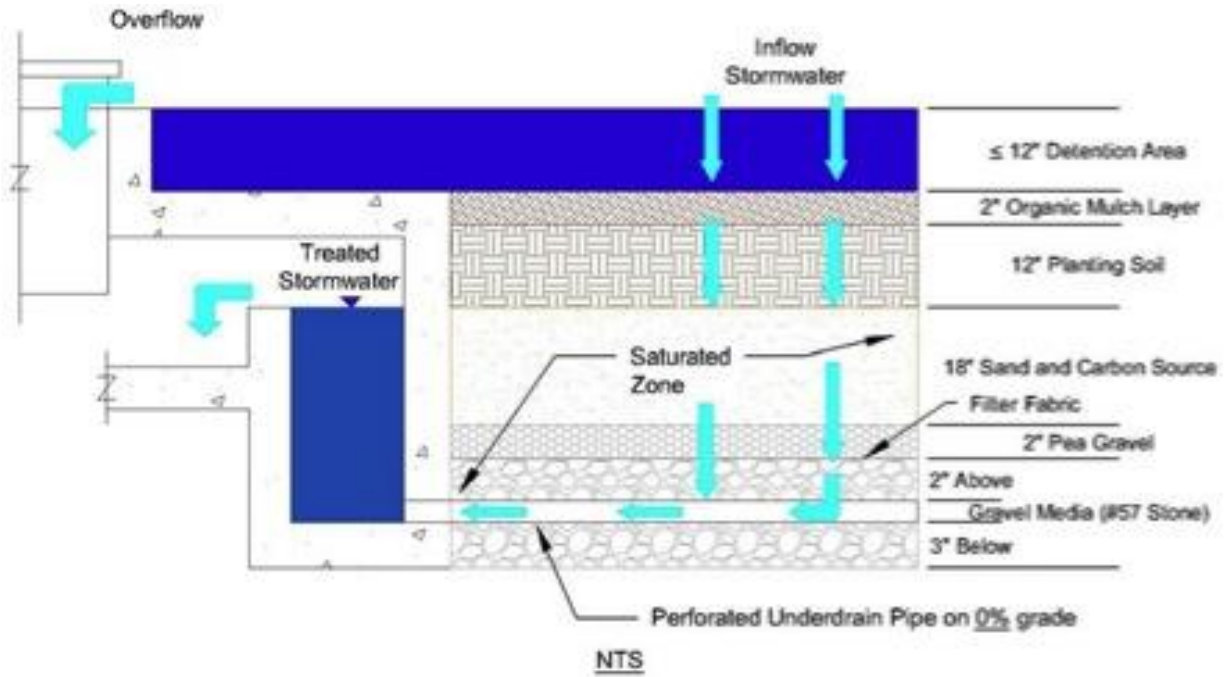

Figure 5.16.4. Example Stormwater Planter Box Biofiltration System

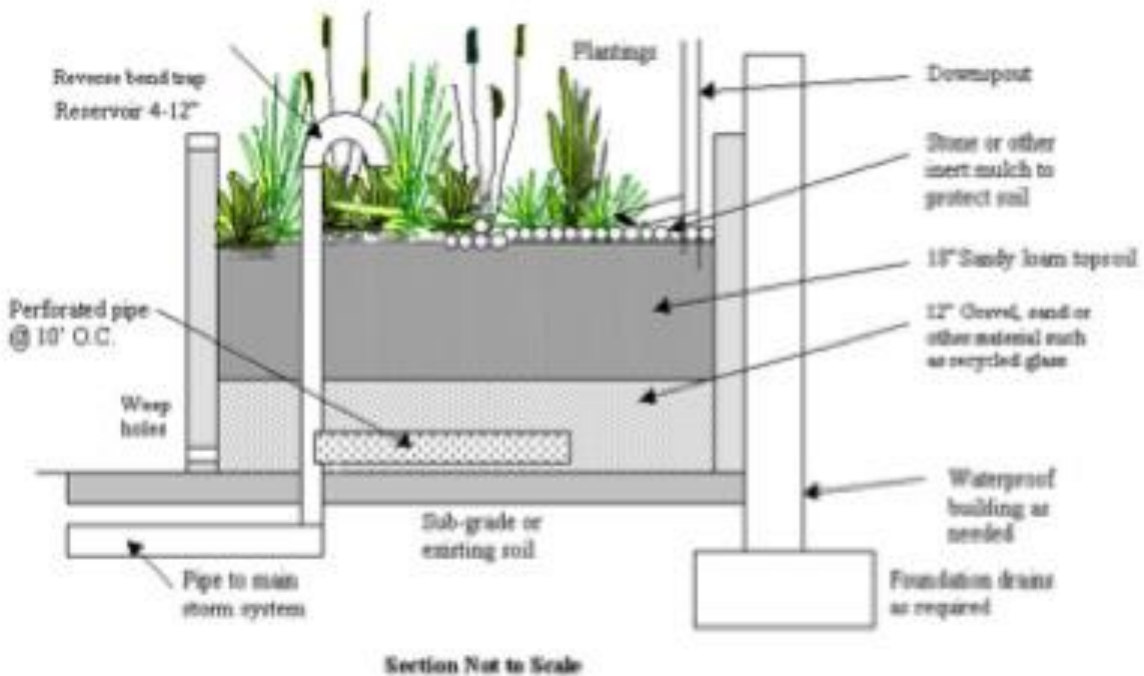
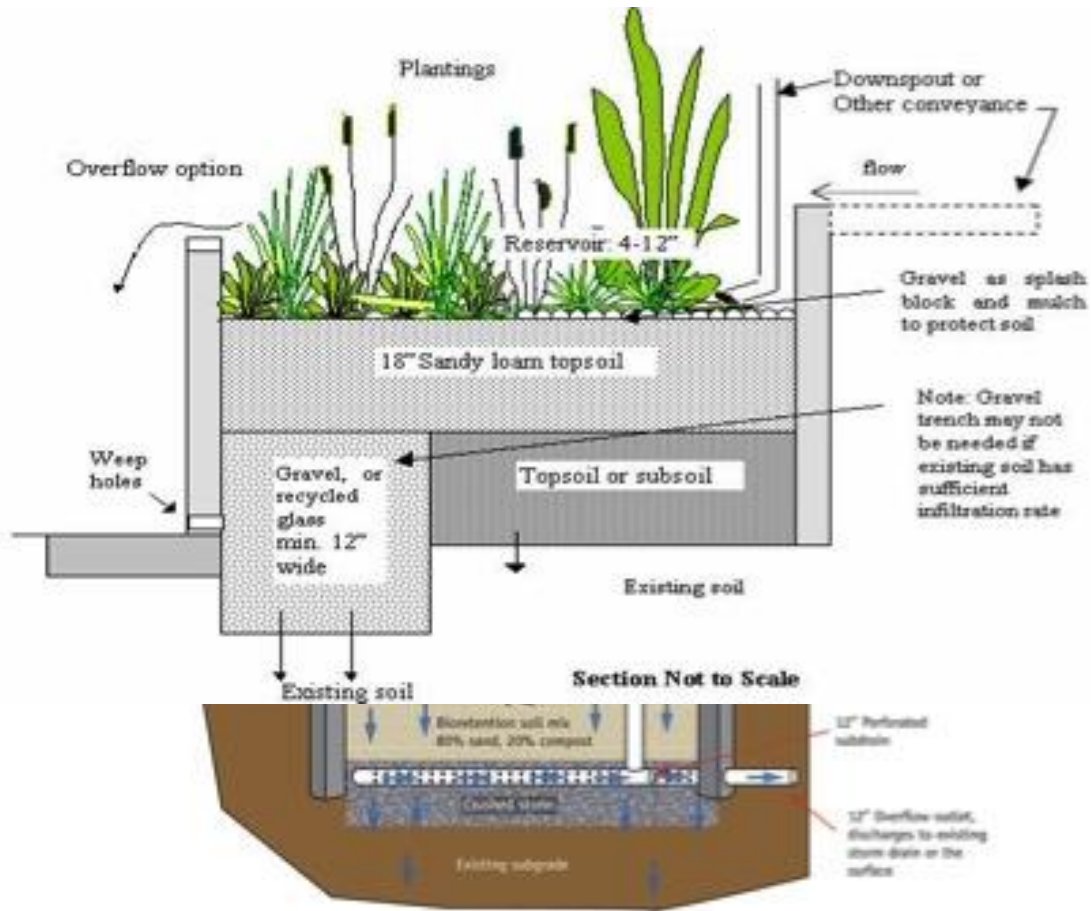

Figure 5.16.5. Example Stormwater Infiltration Planter Box Biofiltration System



### 3. General Feasibility

Biofiltration systems are suitable for many types of development, from single-family residential to high-density commercial projects. Because the shape and sizing of systems are relatively flexible, the systems can be incorporated into many landscaped designs. These systems can be used near [impervious areas](#) such as within roadway medians, parking lot islands, or planter boxes. Biofiltration systems are also well suited for treating runoff from [pervious areas](#), such as recreational fields, golf courses, or landscaped areas. Biofiltration systems may also be used to treat roof runoff, in which case they could be installed with all or a part of the system above ground. If biofiltration systems are installed above ground, the same fundamental design requirements would have to be met as with in-ground biofiltration systems and the biofiltration system would have to discharge through an under-drain system. Biofiltration systems are not suitable for regional stormwater control.

### 4. Physical constraints

When evaluating the appropriateness of a biofiltration system, a designer should consider some of the physical constraints associated with this type of treatment system, including:

- A. Drainage area – usually less than two acres and preferably less than one acre.

- B. Seasonal high water table – separated by structural means from hydraulic contribution of the surrounding water table if SHGWT is within 2 feet of the bottom of the system.
- C. Soils – stormwater must pass through the top soil and BAM before entering the ground water or perforated underdrain discharge pipe.
- D. Discharge - when underdrained, the biofiltration system water must be able to discharge into an appropriate conveyance system such as a storm sewer with adequate capacity.

#### 5.16.4. Design Considerations and Requirements

The following criteria are to be considered minimum standards for the design of biofiltration systems in Alachua County. Consult with applicable WMD to determine whether any variations must be made to these criteria or if additional standards must be followed.

##### 1. Location and Planning

Biofiltration systems are designed for intermittent flow and should not be used on sites with a continuous flow from ground water, sump pumps, or other sources. Locations of biofiltration systems should be integrated into the site-planning process, and aesthetic considerations should be evaluated in their siting and design. All control elevations must be specified to ensure that runoff entering the facility does not exceed the design depth. Biofiltration systems can be installed partly or fully above ground as a planter box to treat roof runoff. However, these systems must still be lined and drained by an underdrain that discharges into an appropriate conveyance system such as a storm sewer with adequate capacity.

##### 2. General Criteria

A detention system with biofiltration must consist of the following:

- A. **Prefilter strip** – Where feasible, a vegetative buffer between the contributing drainage area and the ponding area or swale conveyances must be used to capture coarse sediments and reduce sediment loading to the detention area. The applicant may propose other measures to minimize the sediments entering the biofiltration system. Biofiltration systems that do not include a prefilter strip or other pretreatment measures must include a detailed operation and maintenance plan.
- B. **Ponding area** – An area that provides temporary surface storage (less than 12 inches) for runoff before flowing into and through the soil treatment bed.
- C. **Organic mulch layer** – Is not recommended. Mulches decay and release nutrients and they float leaving the system. However, if used, a two to three inch layer is recommended.
- D. **Planting soil filter bed** – A layer that provides adequate depth of planting media appropriate for the planned vegetation within the basin as well as a sorption site for pollutants and a matrix for soil microbes.
- E. **BAM bed with carbon source (for nitrate removal)** – A layer at least 18 inches thick at the bottom of the biofiltration system that facilitates denitrification under anoxic conditions. This layer also sorbs additional pollutants. If goal is phosphorus removal, a carbon source is not necessary.
- F. **Woody and herbaceous plants** – Florida-friendly plants that provide a carbon source for the biofiltration system, help facilitate microbial activity, and improve infiltration rates. Roots must be kept away from the underdrain.
- G. **Underdrain** - A system facilitating the positive drainage of stormwater through the soil/filtration media and into the discharge conveyance system.
- H. **Control structure** - A structure that creates an anoxic zone up to the elevation of the top of the sand layer.
- I. **Energy-dissipation mechanism** – a structure that reduces runoff velocities, distributes flow, and reduces disturbance of the mulch layer.



- J. **Overflow pipe or spillway** – a structure to allow rainfall events that exceed cell volume capacity to bypass the system. The discharge invert should be set no higher than 12 inches above the soil surface with the applicable downstream erosion-control measures.

### 3. Sizing Requirements

#### A. Prefilter strip

- The prefilter strip design will depend on topography, flow velocities, volume entering the buffer, and site constraints.
- The prefilter strip is typically a vegetated buffer or swale.
- Inflow to the prefilter should be dispersed with low non-erosive velocities.

#### B. Ponding area

- The maximum ponding depth must be no more than 12 inches below the overflow structure.
- The recovery time must be less than 36 hours to ensure plant survival.

#### C. Organic mulch layer (IF USED)

- The surface organic mulch layer must be at least 2 inches deep and cover the surface of the basin to at least 6 inches above the expected high water line.
- Mulch depth must never exceed 4 inches or soil aeration may be reduced.
- Hardwood mulch must be used due to its higher pH, improved microbial activity, and slower decomposition rate. Examples of acceptable mulches are those made from Melaleuca or Eucalyptus trees. Pine bark or pine straw is not acceptable.
- The mulch must be pesticide free.

#### D. Planting soil filter bed

- The planting soil filter bed must be at least 6 inches thick.
- The bed material must be sandy loam, loamy sand, or loam texture.
- Clay content must be between 3 and 5%.
- Soil pH must be suitable for plant growth.
- Top soil organic matter content must be sufficient to support good plant growth.
- The soil mix must be uniform over the volume used and free of stones, stumps, roots, or other similar material greater than 2 inches in size.
- The suggested hydraulic conductivity for the biofiltration system is 1 to 12 inches per hour. Design hydraulic conductivities that fall outside this range must be agreed to in writing during the pre-application meeting.

#### E. Biosorption Activated Media (BAM)

- The sand bed with a carbon source must be at least 24 inches thick.
- The unit weight must be more than 70 pounds per cubic foot when dry.
- No more than 5% of the particles pass through a #200 sieve.
- The media must be more than 50% uniformly graded sand by volume and must not contain shale.
- The media water holding capacity must be at least 30% as measured by porosity.
- The vertical permeability must be at least 2 inches per hour at the specified unit weight noted above.
- The media must have an organic content at least 5% by volume. The organic content must be in the form of 1-inch hardwood chips (e.g. Melaleuca or Eucalyptus woodchips) evenly distributed throughout the layer.
- The pH of the water passing from the media must be between 6.5 and 8.0 or suitable for the selected plant species.
- The concentration of soluble salts must be less than 3.5 g (KCl)/L.



- If interested in phosphorus removal, the sorption capacity of the BAM must exceed 0.005 mg OP/mg media.
- F. Under-drain system
1. Pipe
    - Underdrain pipe must be at least 2-inch-diameter PVC or HDPE pipe.
    - Perforations must meet the AASHTO M 36 or M 196 requirements.
    - Pipe must be spaced no more than 10 feet apart on center.
    - Pipes shall have a positive drainage even under high tailwater conditions.
  2. Gravel media
    - Pipe must be laid on 3 inches of double-washed no. 57 aggregate and then filled around both sides of the pipe and over the top at least three (3) inches. If pea gravel is used, a minimum of 6 inches of fill is required.
    - Gravel must extend to the full width and length of the Sand and Carbon Source Layer to allow for an even flow through this layer
    - The course gravel layer must be overlaid with non-woven, non- degradable filter fabric that meets the geotextile requirements provided in [FDOT Design Standards Index No. 199 for Geotextile Type D-3](#).
    - Filter fabric must be covered with 2 inches of ¼-inch to ½-inch double-washed pea gravel to reduce the likelihood of clogging.
  3. Control structure
    - A control structure that creates an anoxic zone to the top of the sand layer must be placed downstream of the underdrain system if nitrate removal is the target.
    - The control structure must be designed to preclude a siphon from forming.
    - The control structure must be designed so that it does not inhibit maintenance and cleanout of the underdrain system.
4. Discharge Requirements
- The biofiltration system is primarily a water quality treatment system and does not need to meet any specific discharge requirements. However, an overflow structure and non-erosive overflow channel must be provided to safely pass flows that exceed the storage capacity of the biofiltration system to a stabilized downstream area or conveyance system. The complete stormwater treatment system for the site must meet County water quantity discharge requirements.
5. Recovery Requirements
- The appropriate Florida-[registered professional](#) must demonstrate through an underdrain recovery calculation or by underdrain recovery modeling that under high tailwater conditions there is no standing water in the biofiltration system 36 hours after the stormwater treatment volume is applied. The assumed hydraulic conductivity for the planting soil must be stated clearly as this will be used when testing biofiltration systems.
6. Stormwater Quantity Credits
- Biofiltration systems typically are used for stormwater treatment and not for flow attenuation. However, the effectiveness of a biofiltration system at attenuating peak flows can be calculated using one of the following procedures:
- Calculating the Curve Number (CN) for the biofiltration area and including this in the area weighted CN for the entire site.
  - Explicitly modeling the hydraulic functioning of the biofiltration system— including the underdrain and overflow control structures.
7. Stormwater Pollutant Load Requirements/Credits

**No specific treatment requirement is associated with a single biofiltration system.**

These systems are intended to be part of a BMP treatment train, where each practice in the train provides incremental water quality benefits. The level of treatment that can be expected from these systems is based on the average annual volume of water captured and filtered by the biofiltration system and the pollutant load removal efficiency of biofiltration system.

The annual average pollutant-load reduction for metals, nitrogen, and phosphorus must be calculated for a biofiltration system to be considered part of the water quality treatment. Removal efficiencies for all three constituents must be developed using one of the following methods:

- A. Assumed efficiencies – Using two feet of Biosorption Activated Media (BAM), one blend can remove 75% of the annual average nitrogen load reduction and 95% of the phosphorus load (See [Table 6.14.1](#)). There are other BAM mixes that remove less. All levels of treatment are presumed for biofiltration systems that are designed to the minimum recommended design criteria in this Manual. Systems that are designed with substantial deviations from the design criteria will require the removal efficiency to be determined for the specific design in discussions with the County staff at the pre-application meetings. Additionally, the system effectiveness will need to be confirmed using water quality monitoring for a duration and frequency agreed to by the County Staff at the pre-application meetings. If the assumed removal efficiencies are found to exceed the measured removal efficiencies, the County/City may request that the property owner perform on-site mitigation to achieve the permitted removal efficiencies.
- B. Literature values – these must be agreed to in writing by County/City staff at the pre-application meeting.

The percentage of the average annual runoff volume that is filtered by the biofiltration system may be estimated by using one of the following methods:

- A. Continuous simulation - a continuous simulation of the biofiltration system using an applicable long-term rainfall record (at least 20 years).
- B. Figure 5.16.7 may be used to determine the percentage of the average annual volume of water filtered or captured by the biofiltration system. This figure requires that the equivalent impervious area (EIA) and detention volume are known. The EIA is equal to the mean annual runoff coefficient multiplied by the drainage area. Be sure to treat directly connected impervious area as 100% DCIA rather than having a CN of 98.

The average annual pollutant load reduction can then be calculated by multiplying the removal efficiency by the percentage of the average annual runoff that is captured and filtered by the biofiltration system. For example, a system that captures and filters 70% of the average annual runoff volume and has a removal efficiency of 60% for phosphorus will result in a 42% average annual phosphorus load reduction.

**Figure 5.16.7. Example Average Annual Runoff Capture Efficiency of a Biofiltration System in Alachua County for Specific Conditions**

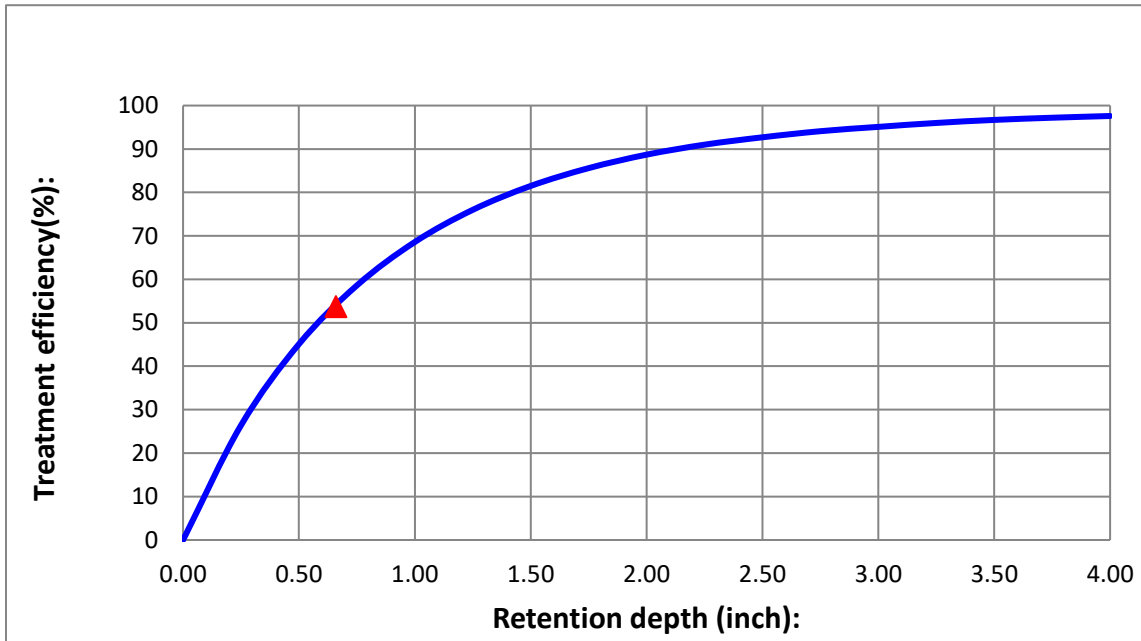

8. Maintenance Access

Access to the biofiltration system must be provided at all times for inspection, maintenance, and landscaping upkeep. There must be sufficient space around the biofiltration system to allow accumulated surface sediments to be removed and possibly for underdrains to be cleaned out or replaced if they should fail infiltration tests or inspection. To facilitate maintenance of the underdrain system, capped and sealed inspection and cleanout ports that extend to the surface of the ground must be provided at the following locations for each drainage pipe at a minimum:

- The beginning and end of each run of pipe.
- At every 50 feet or every bend of greater than 45 or more degrees, whichever is shorter.

9. Safety Features

Due to their shallow ponding depth, biofiltration systems generally do not require any special safety features such as fencing. Railings or a grate can be used to address safety concerns if the area is designed with vertical walls.

10. Landscaping

Landscaping enhances the performance and function of biofiltration systems. Selecting plant material based on hydrologic conditions in the basin and aesthetics will improve plant survival, public acceptance, and overall treatment efficiency. Native or Florida-friendly plants should be selected. All landscaping recommendations should be considered before storm flows are conveyed to the biofiltration system. The following considerations for the landscaping in the contributing drainage area must be followed:

- A. The unpaved contributing area should be well vegetated to minimize erosion and sediment inputs to the biofiltration system.
- B. Where feasible, a prefilter vegetative strip or vegetative swale should be installed.

- C. If used, trees should be spaced 12 to 15 feet apart depending on the type.
- D. Plants should be placed at irregular intervals.
- E. If woody vegetation is used, it should be placed along the banks and edges of the biofiltration system, not in the direct flow path.
- F. Only species well adapted to the regional climate should be used.
- G. Species planted in well-drained media should tolerate short-term ponding as well as periods of low soil moisture.
- H. Plants in the vicinity of the underdrains shall not have extensive root systems that can damage the underdrains.

### 5.16.5. Biofiltration Design Procedure

The following procedures are intended to guide an applicant through the design of a detention system with biofiltration:

- Step 1 – Determine if the development site and conditions are appropriate for the use of a biofiltration system. Consider the Application and Site Feasibility Criteria discussed earlier.
- Step 2 – Determine the drainage area and the equivalent impervious area (EIA) for the drainage area. [EIA = C x Drainage Area].
- Step 3 – Compute the maximum capture volume that will be detained in the surface storage of the biofiltration system (maximum depth 12 inches).
- Step 4 – Set design elevations and dimensions of facility.
- Step 5 – Design a pretreatment system if practicable — either a sediment trap, a vegetative buffer, prefilter strip, or vegetative swale.
- Step 6 – If an underdrain is used, size the underdrain system and downstream control structure.
- Step 7 – Design the emergency overflow. An overflow must be provided to bypass and/or convey larger flows to the downstream drainage system or stabilized watercourse. Non-erosive velocities need to be ensured at the outlet point.
- Step 8 – Determine the Average Annual Pollutant-Load Reduction. This annual average pollutant-load reduction for TN and TP must be calculated.
- Step 9 – Calculate the peak attenuation credit.
- Step 10 – Prepare the vegetation and landscaping plan. A landscaping plan for the biofiltration system should be prepared to indicate how the area would be established with vegetation.

### 5.16.6. Biofiltration Design Example

Assume that a stormwater BMP is needed to help meet the water quality objectives of a site. The portion of a site analyzed in the example includes one acre of paving plus an area that is 80 feet by 30 feet to be used for a biofiltration system. The following are sample calculations for determining the pollutant load removal efficiency of a biofiltration system.

- A. Step 1 – Assume that the applicant has determined that the site meets the criteria specified in [5.16.2](#) and [5.16.3](#). Therefore, a biofiltration system is an appropriate choice for a BMP on this site.
- B. Step 2 – The contributing area is a one-acre paved surface plus a 0.06-acre biofiltration system. The mean annual runoff coefficient for the paved surface and the biofiltration surface is 0.823. Therefore, the EIA for the paving and the biofiltration system is 0.872 acre =  $[1 * 0.823 + 0.06 * 0.823]$ .
- C. Step 3 – The area available for the biofiltration system is limited to approximately 80 feet by 30 feet (Area at top of storage =  $80 * 30 = 2400$  sf). Therefore, using the maximum

detention depth of one foot, and assuming a side slope of 3:1 (area and bottom of storage =  $74 * 24 = 1776$  sf) the maximum detention volume detained on the surface of the biofiltration area is calculated to be  $2,088 = [((2400 \text{ sf} + 1776 \text{ sf})/2) * 1 \text{ foot}]$  cubic feet.

- D. Step 4 – Biofiltration design data are specified, such as the design elevations and the treatment rate. Treatment rate must consider the expected life time of the design and as such must be modified to account for decreased in rate over time. A design factor of two (2) is typical. As an example, a design rate of 2 inches per hour is based on a rate of 4 inches per hour when using laboratory of double-ring infiltration data.
- E. Step 5 – Assume that the applicant has found that there is sufficient space for a prefilter strip. If the biofiltration system also incorporates infiltration, having a prefilter reduces the frequency of infiltration rate testing to once every 3 years, rather than once every 18 months, which is required if no prefilter strip is included. (See Table 3.1)
- F. Step 6 – The applicant then sizes the underdrain to recover in 72 hours and to create the anoxic zone for nitrate removal. This assumes that a design (safety) factor of two is used for the treatment rate. If the treatment rate is not divided by two (safety factor), then the recovery must take place in 36 hours (applying the design factor to the recovery time).
- G. Step 7 – Ensure that flood control is provided to meet Alachua County requirements.
- H. Step 8 – The average annual pollutant removal efficiency would be calculated. Dividing the detention volume by the EIA gives a treatment volume of 0.66 ( $2088 \text{ cf} / .872 \text{ acre} * 12 / 43560$ ) inch over the EIA. [Figure 5.16.7](#) shows that approximately 53% of the average annual runoff (see triangle in the Figure) would be captured for filtration by the biofiltration system. Given that the system provides a 45% removal of nitrogen, it can be calculated that the system would achieve a 24% reduction in nitrogen loading from the paved area.

### 5.16.7. Operation and Maintenance

1. Routine Inspections - The operation and maintenance entity must conduct regular inspections of the biofiltration system immediately after a rainfall to ensure it is operating as permitted. At a minimum, an inspection should occur in the spring, before the rainy season begins in June, and during the rainy season. At a minimum the following should be inspected:
  - Inspect inflow/outflow points for any clogging.
  - Inspect prefilter strip vegetated buffer/grass swale and ponding area for erosion or gullyng.
  - Inspect trees and shrubs to evaluate their health.
  - Inspect the underdrain system to ensure it is not clogged.
2. To ensure the system is properly maintained and to continue to receive stormwater treatment credits, the operation and maintenance entity must:
  - Prune and weed to keep any structures clear.
  - Maintain/mow the vegetated buffer, prefilter strip or swale at least twice during the growing season and remove clippings from the flow path.
  - If used, replace mulch where needed when erosion is evident.
  - If used, replace mulch over the entire area every 2 to 3 years.
  - Remove trash and debris as needed.

- Remove sediment from inflow system and outflow system, including underdrains, as needed. Flush underdrains as needed to maintain their flow capacity.
  - Stabilize any upstream erosion as needed.
  - Remove and replace any dead or severely damaged vegetation.
3. Recertification Inspection and Testing - The operation and maintenance entity is required to provide for the inspection of the entire stormwater management system by a Florida registered professional to assure that the system is properly operated and maintained. The inspections shall be performed in accordance with either the schedule in the WMD permit or the schedule in Table 3.1. The report is due to the County/City within 30 days of the date of inspection.

A Florida-[registered professional](#) must conduct testing to provide reasonable assurance that the biofiltration system is functioning as intended. Results, as well as remedial actions, must be reported to the County. For sites that include several biofiltration systems, a testing schedule in which a representative sample of biofiltration systems are tested at the appropriate interval may be agreed to at the pre-application meeting or during the permitting process. Testing must include the following:

- The planting soils pH must be tested at least once every 3 years. Planting soils pH must be suitable for the plants used.
- Biofiltration systems that include infiltration components require that a double-ring infiltration test be performed every 3 years at up to three locations in the bottom of the basin to confirm design infiltration rates. An alternative to the double-ring is staff gage depth measurements from a ponded area. The staff gage is preferred for operating systems. If two out of three tests are below the design treatment rate criteria or the average rate of the three tests is below the design criteria, the biofiltration system media must be restored. Core aeration or cultivating of non-vegetated areas may be sufficient to ensure adequate filtration.

**5.16.8. Planter Box Biofiltration Systems**

1. **Description** - Planter box biofilters are structural landscaped reservoirs used to collect and filter stormwater, allowing pollutants to settle and filter out as the water percolates through the vegetation, growing medium, and gravel. Excess stormwater collects in a perforated pipe at the bottom of the flow through planter and drains to an approved discharge point and conveyance. Planters can be used to help fulfill a site's required landscaping area requirement and should be integrated into the overall site

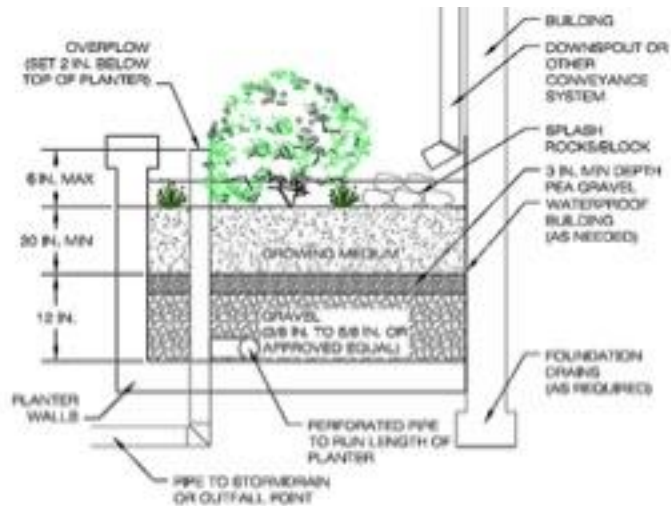

design. Numerous design variations of shape, wall treatment, and planting scheme can be used to fit the character of a site. Because flow-through planters can be constructed immediately next to buildings, they are ideal for sites with setback requirements, poorly



draining soils, or other constraints. All of the above requirements for biofiltration systems apply to Planter Box biofilters unless they are superseded by specific requirements below.

2. **Setbacks** - Biofiltration planters that rely on infiltration are typically set back 5 feet from property lines and 10 feet from building foundations. No setbacks are required for lined flow-through planters where the height above finished grade is 30 inches or less. Lined flow-through planters can be used next to foundation walls, adjacent to property lines, or on slopes when they include a waterproof lining.
3. **Contributing drainage area** - The maximum contributing drainage area is 2,500 sq. ft. However, this is considered a general rule. Larger drainage areas may be allowed by the County/City if the biofiltration system has sufficient flow controls and other mechanisms to ensure proper function, safety, and community acceptance. The drainage areas in these urban settings are typically considered to be 100% impervious.
4. **Planter biofiltration system sizing and pollutant load reduction** - Planter biofiltration systems that use infiltration and are not underdrained can be sized similar to retention basins by using [Table B2-1](#) to determine the desired treatment volume. The treatment volume will then determine the annual load reduction percentage. If the biofiltration system requires an underdrain and discharges off-site, the desired treatment volume and the biofiltration media characteristics will determine the area of the biofiltration system. These, in turn, will determine the pollutant load reduction. The treatment volume is determined from the sustainable porosity of the media.
5. **Dimensions and slopes** - The minimum infiltration planter width is 30 inches, and the minimum flow-through planter width is 18 inches (measured from inside the planter walls). Storage depth must be between 6 and 12 inches (from inlet elevation of overflow to top of growing medium). Planters are flat facilities that do not slope more than 0.5 percent in any direction. A minimum of 2 inches of freeboard (vertical distance between the design water surface elevation and overtopping elevation) shall be provided.
6. **Planter walls** - Planter walls shall be made of stone, concrete, brick, or other durable material. For planters that require an impervious bottom, a single-pour concrete solution is preferred. Chemically treated wood that can leach out toxic chemicals and contaminate stormwater shall not be used.
7. **Liners** - Flow-through facilities that require an impervious bottom can use either a waterproof liner (geomembrane) or a single-pour concrete box. If lined, there are many liner options, and installation varies. Liners should be installed to the high water mark. Liner shall be 30 to 40- mil PVC or HDPE as appropriate or approved equivalent.
8. **Vegetation** - The entire planter box filter must be planted with vegetation. The facility area is equivalent to the total area of the planter, as developed in the sizing calculations. The entire surface area of a planter is inundated with water and therefore requires plants that will survive such conditions. Minimum quantities are shown below:

Minimum Vegetation Quantities			
NUMBER OF PLANTS/100 sq. ft	TYPE OF PLANTS	SIZE	SPACING ON CENTER
115	Herbaceous	1 gallon	1'
100	Herbaceous	1 gallon	1'
4	Small shrubs	1 gallon	2'

Tree planting is not required in planters but is encouraged where practical. Tree planting is also encouraged near planters.

9. **Construction Considerations** - Special attention should be paid to the structural waterproofing if the planter is constructed adjacent to building structures.

5.16.9. **Tree Box Filter Systems**

1. **Description** - Tree box filters typically are pre-cast concrete boxes filled with biofiltration media installed below grade at the curb line. A standard street tree or shrub is planted in the box, which resembles a curbside planter. Tree box filters are located upstream of a standard curb inlet. For low to moderate flows, stormwater enters through the tree box's inlet, filters through the soil, and exits through an underdrain into the storm drain. When the tree box filter is full, excess street flows will bypass the tree box filter and flow directly to the downstream curb inlet. They serve as attractive landscaping and



stormwater catch basins. Unlike many other forms of urban landscaping, they are not isolated behind curbs and deprived of water and nutrients in runoff. Their water quality treatment performance is moderate, depending on the size and composition of the filter media. In those cases where the soils are appropriate for infiltration, the tree box filter should be designed following the recommendations for [Interceptor Trees](#).

2. **Applicability** - Tree box filters can be used throughout Florida, and are especially useful in highly urbanized settings where available space is at a premium. They can be installed in open- or closed-bottomed chambers where infiltration is undesirable or not possible, such as clay soils, sites with high ground water, and areas with highly contaminated runoff.

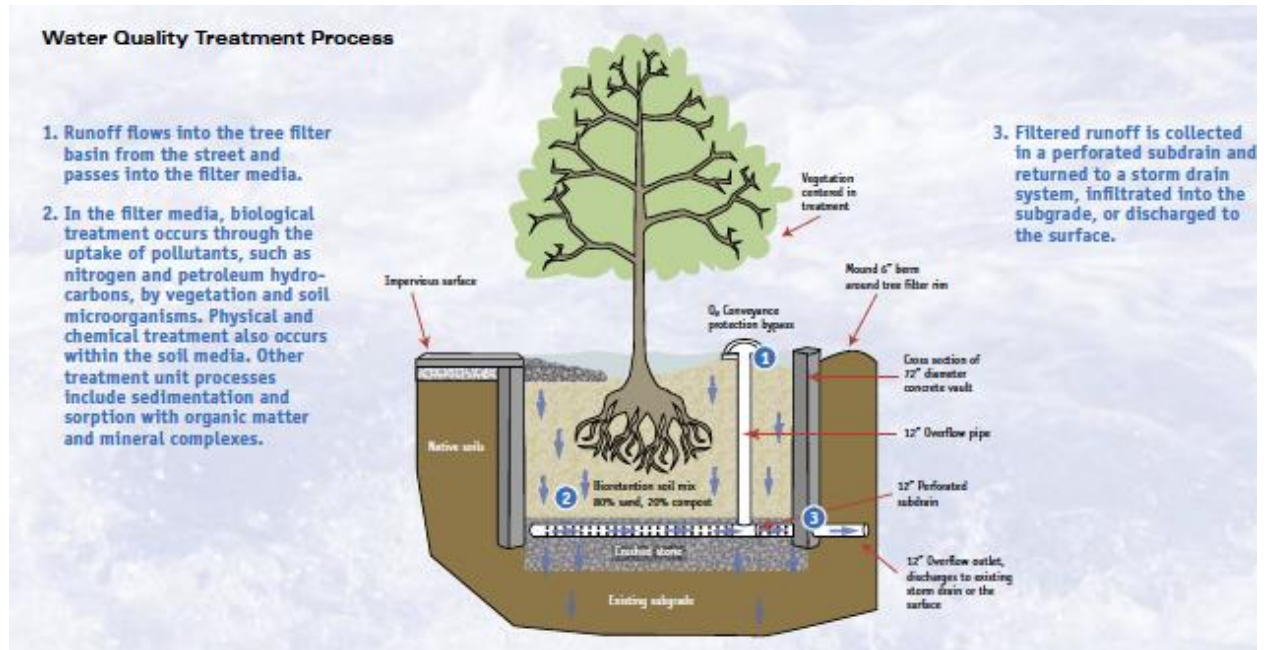

Tree box filters are often installed along urban sidewalks, but they are highly adaptable and can be used in most development scenarios. In urban areas, tree filters can be used in the design of an integrated street landscape—a choice that transforms isolated street trees into stormwater filtration devices. They also can be used in designs that seek to convert entire non-functional streetscapes into large stormwater filtration systems.

3. **Water quantity benefits** - Individual tree box filters hold a relatively small volume of stormwater (100-300 gallons), but concerted use throughout a contributing drainage area will decrease the total volume and peak flow rate of discharged stormwater. Tree box filters are designed to capture the water quality volume of stormwater. They are not intended to capture larger volumes or to detain the water quality volume for extended periods of time, however.
4. **Water quality benefits** - Tree box filters remove pollutants through the same physical, chemical, and biological mechanisms as other biofiltration systems, and have moderate removal rates for pollutants in stormwater. They also provide the added value of aesthetics while making efficient use of available land for stormwater management.
5. **Design Criteria**
  - A. **In general**, tree box filters are sized and spaced much like catch basins, and design variations for these systems are abundant. The tree box filter's basic design is a concrete vault filled with a biofiltration media, planted with vegetation, with an underdrain. The bottom is usually closed unless the soils are appropriate for infiltration.
  - B. **Soil volume requirements** – When planting trees, the volume of soil provided must be considered carefully. It must be adequate for root development or the tree will not grow to a full size, and its health may be impacted. At maturity, tree roots often extend more than twice as far as the tree's canopy. In urban settings, that ideal volume is usually not available, but the reduction in volume of soil will directly impact the potential size of the tree. A tree box containing 120 ft<sup>3</sup> (in a typical 4' x 10' x 3' tree box) might allow a tree to spread to about 10 ft. diameter canopy before it declines. The same tree in a box containing 500 ft<sup>3</sup> could be expected to grow to a diameter of more than 20 ft. Void spaces in the soil are also necessary for the tree to obtain both water and air, so it is important that the surrounding soil is uncompacted. Several good design references for tree boxes include:
    - <http://caseytrees.org/resources/publications/treespacedesign/>
    - <http://caseytrees.org/wp-content/uploads/2012/02/tree-space-design-report-2008-tsd.pdf>
    - [http://www.davey.com/media/183712/Stormwater\\_to\\_Street\\_Trees.pdf](http://www.davey.com/media/183712/Stormwater_to_Street_Trees.pdf)
  - C. **Tree species** - The trees selected shall be Florida-friendly suitable species for the site conditions and the design intent. The Alachua County Approved Plant List is found in Table 407.50.1 – Appropriate Tree Plantings in Section 407.50 of Article 4 – Landscaping of the ULDC. Alachua County may require a certified arborists report to verify suitable tree selection and preservation. Plants with aggressive root growth may clog the underdrain, and therefore may not be suitable for this type of system. The tree box filter can be sized for a specific stormwater treatment volume and should allow for four to six inches of ponding. Larger storm events will be bypassed.
  - D. **Tree box components** - Tree box filters consist of a pre-cast concrete container, a mulch layer, biofiltration media mix, observation and cleanout pipes, underdrain pipes, one street tree or large shrub, and a grate landscape cover.
  - E. **Contributing drainage area** - Tree boxes typically treat runoff from a drainage area of a 0.25 acre or less, although drainage area size is a function of tree box filter size. and

- F. **Location and spacing** - Tree boxes must be regularly spaced along the length of a corridor as appropriate to meet the desired annual treatment target. A standard curb inlet must be located downstream of the tree box filter to intercept bypass flow. Tree box filters are off-line devices and should never be placed in a sump position (i.e. low point). Instead, runoff should flow across the inlet (e.g. left to right). Also, tree box filters are intended for intermittent flows and must not be used as larger event detention devices.
- G. **Inspection and maintenance** - Tree box filters should be inspected annually in the spring before the rainy season begins. To ensure proper performance, visually inspect that stormwater is infiltrating properly into the tree box filter. Excessive volumes of stormwater bypassing the tree box filter to the standard inlet may indicate operational problems. Corrective measures to restore performance include inspection for accumulated sediments and debris and removal, if necessary. In instances where the condition of the soil media has degraded significantly, the media and vegetation should be removed.
- H. Routine maintenance consists of regular removal of trash and debris and vegetation maintenance. The mulch will need to be replenished one (1) to two (2) times per year. The cleanout pipe can be used to flush the system if the underdrain becomes clogged. During extreme droughts, the trees or shrubs may need to be watered in the same manner as any other landscaping. The plants may need to be replaced every few years.

# ALACHUA COUNTY STORMWATER MANAGEMENT MANUAL



## APPENDICES

Page intended to be blank



# APPENDIX A. LIST OF ALACHUA COUNTY RECEIVING WATERS AND THEIR CURRENT IMPAIRMENT STATUS, TMDL STATUS, BMAP STATUS

The following table lists the receiving waters in Alachua County to which the FDEP has assigned [Water Body ID \(WBID\)](#) numbers. The table includes the impairment status and whether a [Total Maximum Daily Load](#) or [Basin Management Action Plan](#) has been adopted for the [impaired water](#) body. This list is current as of March 2016. For more recent information, please see the web sites in [Section 1.3.5](#) of the Manual

WATER BODY	WBID NO.	WATER TYPE	IMPAIRED STATUS	POLLUTANT OF CONCERN	TMDL STATUS	TMDL % REDUCTION	BMAP STATUS	WATERSHED
AIRPORT DRAIN	2707	STREAM						Oklawaha River
ALACHUA SINK	2720A	LAKE	YES	Fecal Coliform Nutrients (TN)	FDEP ADOPTED	TN = 45%	Orange Creek BMAP	Oklawaha River
ALACHUA SINK OUTLET	2720	STREAM	YES	Dissolved Oxygen (TN, BOD) Fecal Coliform				Oklawaha River
ALTHO DRAINAGE	3605F	STREAM	YES	Dissolved Oxygen(TN)				Santa Fe River
BIVANS ARM	2718B	LAKE	YES	Nutrients (TN, TP)				Oklawaha River
BIVANS ARM OUTLET	2718	STREAM	YES	Dissolved Oxygen(TN,TP) Nutrients (TN)				Oklawaha River

BLUE POND	2735A	LAKE						Oklawaha River
BLUE POND OUTLET	2735	STREAM						Oklawaha River
BLUES CREEK	3682	STREAM	YES	Fecal Coliform	FDEP ADOPTED	Concentration based		Santa Fe River
BRUNTBIDGE BROOK	2736	STREAM						Oklawaha River
BURNETTS LAKE DRAIN	3670	STREAM						Santa Fe River
CALF POND	2720B	LAKE						Oklawaha River
CAMPS CANAL	2733	STREAM	YES	Dissolved Oxygen(TN)				Oklawaha River
CHACALA POND OUTLET	2737	STREAM						Oklawaha River
COLEMAN CEMETERY BOG	2734	STREAM						Oklawaha River
COLUMBIA SPRINGS	3605T	SPRING						Santa Fe River

COWPEN LAKE	2723A	LAKE						Oklawaha River
COWPEN LAKE OUTLET	2723	STREAM						Oklawaha River
CROSS CREEK	2754	STREAM	YES	Dissolved Oxygen Nutrients (TN, TP)	FDEP	TN = 43% TP = 31%		Oklawaha River
DEEP CREEK RODMAN RESERVOIR	2730	STREAM						Oklawaha River
DEER BACK LAKE	2747Y	LAKE						Oklawaha River
EAST LAKE	2714X	LAKE						Oklawaha River
EVINSTON DRAIN	2757	STREAM						Oklawaha River
FANNY LAKE	2732X	LAKE						Oklawaha River
FISH PRAIRIE CREEK	2755	STREAM						Oklawaha River

GALILEE LAKE	2714C	LAKE						Oklawaha River
GALILEE LAKE OUTLET	2714	STREAM						Oklawaha River
GILLIS POND	2732Y	LAKE						Oklawaha River
GOOSKI PRAIRIE	2764	STREAM						Oklawaha River
GUM CREEK	2715	STREAM						Oklawaha River
HAGUE BRANCH	3678A	STREAM	YES	Fecal Coliform	FDEP ADOPTED	Concentration based		Santa Fe River
HAILE SINK	2717A	LAKE						Oklawaha River
HAMMOCKS LAKE	2700	LAKE						Oklawaha River
HATCHET CREEK	2688	STREAM	YES	Fecal Coliform Nutrients (TN,TP)  Iron	EPA  FDEP ADOPTED	83%  30.8%		Oklawaha River

HAWTHORN PRAIRIE OUTLET	2761	STREAM						Oklawaha River
HEWITT LAKES	2743A	LAKE						Oklawaha River
HEWITT LAKES OUTLET	2743	STREAM						Oklawaha River
HIGGINBOTHAM LAKE	2732A	LAKE						Oklawaha River
HIGGINBOTHAM LAKE OUTLET	2732	STREAM						Oklawaha River
HOGTOWN CREEK	2698	STREAM	YES	Fecal Coliform	FDEP ADOPTED	51%	Orange Creek BMAP	Oklawaha River
HOLDENS POND	2713C	LAKE						Oklawaha River
HORNSBY SPRING	3653Z	SPRING						Santa Fe River
HORNSBY SPRING RUN	3653	SPRING						Santa Fe River
IRVINE DRAIN	2759	STREAM						Oklawaha River



IRVING SLOUGH	2760	STREAM					Oklawaha River
ISLAND LAKE	2753A	LAKE					Oklawaha River
ISLAND LAKE DRAIN	2753	STREAM					Oklawaha River
JOHNSON LAKE	2713G	LAKE					Oklawaha River
KANAPAHA LAKE	2717	LAKE	YES	Dissolved Oxygen (TN, TP, BOD)			Oklawaha River
KANAPAHA LAKE OUTLET	2717B	STREAM					Oklawaha River
KEY POND	2748X	LAKE					Oklawaha River
L. FISH POND	2747X	LAKE					Oklawaha River
LAKE ALICE	2719A	LAKE					Oklawaha River
LAKE ALICE OUTLET	2719	STREAM	YES	Fecal Coliform			Oklawaha River

LAKE ALTO	3605H	LAKE						Santa Fe River
LAKE ELIZABETH	2699A	LAKE						Oklawaha River
LAKE ELIZABETH OUTLET	2699	STREAM						Oklawaha River
LAKE JEFFORDS	2739A	LAKE						Oklawaha River
LAKE JEFFORDS OUTLET	2739	STREAM						Oklawaha River
LAKE MOON	2706	LAKE						Oklawaha River
LAKE OCKLAWAHA	2740B	LAKE						Oklawaha River
LAKE WINNOTT	2713F	LAKE						Oklawaha River
LITTLE HATCHET CREEK	2695	STREAM	YES	Dissolved oxygen (TN,TP) Fecal Coliform				Oklawaha River

LITTLE MONTEOCHA CREEK	3663	STREAM						Santa Fe River
LITTLE ORANGE CREEK	2713	STREAM	YES	Fecal Coliform				Oklawaha River
LITTLE ORANGE LAKE	2713D	LAKE						Oklawaha River
LITTLE WACCASASSA RIVER	3747	STREAM						Waccasassa River
LOCHLOOSA CREEK	2693	STREAM						Oklawaha River
LOCHLOOSA LAKE	2738A	LAKE	YES	Nutrients (TN,TP)	FDEP	TN = 59% TP = 41%	Orange Creek BMAP	Oklawaha River
LOCHLOOSA LAKE OUTLET	2738	STREAM		Nutrients (TN,TP)	EPA	TN= 38% TP=60%		Oklawaha River
LOCHLOOSA SLOUGH	2751	STREAM	YES	Dissolved Oxygen (TN, TP)				Oklawaha River
MCCARTHY LAKE	2748A	LAKE						Oklawaha River

MCCARTHY LAKE OUTLET	2748	STREAM						Oklawaha River
MCMEEKIN LAKE	2729A	LAKE						Oklawaha River
MCMEEKIN LAKE OUTLET	2729	STREAM						Oklawaha River
MILL CREEK	2756	STREAM						Oklawaha River
MILL CREEK SINK	3644	STREAM	YES	Fecal Coliform Dissolved oxygen (TP)	FDEP ADOPTED	Concentration based		Santa Fe River
MONTEOCHA CREEK	3654	STREAM	YES	Fecal Coliform	FDEP ADOPTED	Concentration based		Santa Fe River
MORANS PRAIRIE DRAIN	2702	STREAM						Oklawaha River
MORRIS LAKE	2714A	LAKE						Oklawaha River
MOSS LEE LAKE	2713A	LAKE						Oklawaha River
NEWNANS LAKE	2705B	LAKE	YES	Dissolved Oxygen(TN,TP)	FDEP ADOPTED	TN=74% TP=59%	Orange Creek BMAP	Oklawaha River

NEWNANS LAKE OUTLET	2705	STREAM						Oklawaha River
NONCONTRIBUTING AREA	2692	STREAM						Oklawaha River
NONCONTRIBUTING AREA	2765	STREAM						Oklawaha River
NONCONTRIBUTING AREA	3675	STREAM						Waccasassa River
NORTH TWIN LAKE	2723X	LAKE						Oklawaha River
OCKLAWAHA RIVER ABOVE ST JOHNS RIVER	2740A	STREAM						Oklawaha River
ORANGE CREEK	2747	STREAM						Oklawaha River
ORANGE LAKE	2749A	LAKE	YES	Dissolved Oxygen (TP)	FDEP ADOPTED	45%	Orange Creek BMAP	Oklawaha River
ORANGE LAKE DRAIN	2749B	STREAM	YES	Dissolved Oxygen (TN,TP)				Oklawaha River

PARENERS BRANCH	3626	STREAM	YES	Fecal Coliform	FDEP ADOPTED	Concentration based		Santa Fe River
PAYNES PRAIRIE	2721	STREAM					Orange Creek BMAP	Oklawaha River
PEGRAM LAKE	2753X	LAKE						Oklawaha River
POE SPRING	3605W	SPRING						Santa Fe River
POSSUM CREEK	2696	STREAM	YES	Fecal Coliform				Oklawaha River
PRAIRIE CREEK	2705A	STREAM	YES	Dissolved Oxygen (TN, BOD)				Oklawaha River
PRIEST PRAIRIE DRAIN	2750	STREAM						Oklawaha River
REDDICK SLOUGH	2762	STREAM						Oklawaha River
REDWATER LAKE	2713B	LAKE						Oklawaha River
RHUDA BRANCH	3648	STREAM						Santa Fe River



RILEY LAKE	2742X	LAKE						Oklawaha River
RIVER STYX	2744A	STREAM						Oklawaha River
ROCKY CREEK	3641	STREAM						Santa Fe River
SALUDA SWAMP DRAIN	2691	STREAM						Oklawaha River
SANCHEZ PRAIRIE	3681A	STREAM						Santa Fe River
SANTA FE LAKE	3605G	LAKE						Santa Fe River
SANTA FE RISE	3605R	SPRING						Santa Fe River
SANTA FE RIVER	3605	STREAM						Santa Fe River
SANTA FE RIVER	3605C	STREAM	YES	Dissolved Oxygen(NOx)	FDEP ADOPTED	35%	Santa Fe River BMAP	Santa Fe River
SANTA FE RIVER	3605D	STREAM						Santa Fe River

SANTA FE RIVER	3605E	STREAM						Santa Fe River
SANTA FE SPRING	3605U	SPRING						Santa Fe River
SOUTH BULL POND	2713E	LAKE						Oklawaha River
STAR LAKE OUTLET	2742	STREAM						Oklawaha River
SUNLAND DRAIN	2709	STREAM	YES	Fecal Coliform				Oklawaha River
SUNSHINE LAKE	3648A	LAKE						Santa Fe River
SWEETWATER BRANCH	2711	STREAM	YES	Fecal Coliform	FDEP ADOPTED	70%	Orange Creek BMAP	Oklawaha River
SWEETWATER BRANCH EXTENSION DITCH	2722	STREAM						Oklawaha River
TOWNSEND BRANCH	3642	STREAM						Santa Fe River
TREEHOUSE SPRING	3605Q	SPRING						Santa Fe River

TROUT POND	3655A	LAKE						Santa Fe River
TROUT POND OUTLET	3655	STREAM						Santa Fe River
TUMBLIN CREEK	2718A	STREAM	YES	Fecal Coliform	FDEP ADOPTED	74%	Orange Creek BMAP	Oklawaha River
TURKEY CREEK	3671A	STREAM	YES	Fecal Coliform	FDEP ADOPTED	Concentration based		Santa Fe River
TUSCAWILLA LAKE	2752A	LAKE						Oklawaha River
TUSCAWILLA LAKE OUTLET	2752	STREAM						Oklawaha River
UNNAMED BRANCH	2704	STREAM						Oklawaha River
UNNAMED BRANCH	3609	STREAM						Santa Fe River
UNNAMED BRANCH	3627	STREAM						Santa Fe River
UNNAMED BRANCH	3637	STREAM						Santa Fe River

UNNAMED BRANCH	3647	STREAM						Santa Fe River
UNNAMED BRANCH	3651	STREAM						Santa Fe River
UNNAMED BRANCH	3657	STREAM						Santa Fe River
UNNAMED BRANCH	3664	STREAM						Santa Fe River
UNNAMED BRANCH	3666	STREAM						Santa Fe River
UNNAMED BRANCH	3669	STREAM						Santa Fe River
UNNAMED CREEK	3621	STREAM						Santa Fe River
UNNAMED CREEK	3625	STREAM						Santa Fe River
UNNAMED CREEK	3658	STREAM						Santa Fe River
UNNAMED DRAIN	2694	STREAM						Oklawaha River

UNNAMED DRAIN	2701	STREAM						Oklawaha River
UNNAMED DRAIN	2710	STREAM	YES	Fecal Coliform				Oklawaha River
UNNAMED DRAIN	2746	STREAM						Oklawaha River
UNNAMED DRAIN	2763	STREAM						Oklawaha River
UNNAMED DRAIN	3623	STREAM						Santa Fe River
UNNAMED DRAIN	3665	STREAM						Santa Fe River
UNNAMED RUN	2727	STREAM						Oklawaha River
UNNAMED SLOUGH	2685	STREAM						Oklawaha River
UNNAMED SLOUGH	2686	STREAM						Oklawaha River
UNNAMED SLOUGH	2687	STREAM						Oklawaha River

UNNAMED SLOUGH	2689	STREAM					Oklawaha River
UNNAMED SLOUGH	2690	STREAM					Oklawaha River
UNNAMED SLOUGH	2697	STREAM					Oklawaha River
UNNAMED SLOUGH	2703	STREAM					Oklawaha River
UNNAMED SLOUGH	2712	STREAM					Oklawaha River
UNNAMED SLOUGH	2726	STREAM					Oklawaha River
UNNAMED SLOUGH	2758	STREAM					Oklawaha River
UNNAMED SLOUGH	3638	STREAM					Santa Fe River
UNNAMED SLOUGH	3660	STREAM					Santa Fe River
WACCASASSA RIVER	3699	STREAM	YES	Fecal Coliform			Waccasassa River



WATERMELON POND	3703A	LAKE						Waccasassa River
WATSON PRAIRIE DRAIN	2745	STREAM						Oklawaha River
WAUBERG LAKE	2741A	LAKE					Orange Creek BMAP	Oklawaha River
WAUBERG LAKE OUTLET	2741	STREAM	YES	Nutrients (TN, TP)	FDEP ADOPTED	TN= 51% TP = 50%	Orange Creek BMAP	Oklawaha River
WEST HAWTHORNE BRANCH	2728	STREAM						Oklawaha River
WEST LAKE ST. RUN	2731	STREAM						Oklawaha River

# APPENDIX B. RAINFALL ZONE 2 RETENTION BMP TREATMENT VOLUMES AND AVERAGE ANNUAL POLLUTANT LOAD REDUCTIONS.

Table B1-1 presents the dry retention treatment depths for an average annual pollutant load reduction of 80 Percent in Rainfall Zone 2.

Table B2-1 consists of a series of tables of different dry retention treatment depths, from 0.25” to 4.00,” as a function of DCIA and non-DCIA Curve Number, with the corresponding average annual pollutant load reduction effectiveness.

**Table B1-1. Required Retention Treatment Volumes (in Inches) to Achieve an 80% Average Annual Pollutant Load Reduction in Rainfall Zone 2.**

(From Evaluation of Current Stormwater Design Criteria within the State of Florida, Final Report Submitted to the FDEP, June 2007, Harvey Harper and David Baker, Environmental Research and Design, Inc.)

NDCIA CN	Percent DCIA																		
	10	15	20	25	30	35	40	45	50	55	60	65	70	75	80	85	90	95	100
30	0.22	0.24	0.32	0.40	0.46	0.51	0.60	0.67	0.73	0.80	0.87	0.94	1.01	1.08	1.15	1.22	1.29	1.36	1.43
35	0.23	0.24	0.33	0.41	0.46	0.52	0.60	0.67	0.73	0.80	0.88	0.94	1.01	1.08	1.15	1.22	1.29	1.36	1.43
40	0.23	0.26	0.35	0.42	0.47	0.53	0.61	0.68	0.74	0.81	0.88	0.95	1.01	1.09	1.16	1.22	1.29	1.36	1.43
45	0.24	0.28	0.37	0.43	0.48	0.55	0.62	0.69	0.74	0.82	0.89	0.95	1.02	1.09	1.16	1.22	1.29	1.36	1.43
50	0.27	0.32	0.39	0.45	0.49	0.57	0.64	0.70	0.76	0.83	0.90	0.96	1.03	1.10	1.16	1.23	1.30	1.37	1.43
55	0.35	0.38	0.42	0.47	0.52	0.59	0.66	0.71	0.77	0.84	0.91	0.97	1.04	1.11	1.17	1.23	1.30	1.37	1.43
60	0.45	0.44	0.46	0.50	0.56	0.62	0.68	0.73	0.80	0.86	0.93	0.98	1.05	1.11	1.18	1.24	1.30	1.37	1.43
65	0.57	0.52	0.53	0.56	0.61	0.66	0.71	0.76	0.83	0.89	0.95	1.00	1.06	1.13	1.19	1.25	1.31	1.37	1.43
70	0.70	0.65	0.63	0.65	0.68	0.72	0.76	0.81	0.87	0.92	0.97	1.03	1.09	1.14	1.20	1.25	1.31	1.37	1.43
75	0.84	0.78	0.76	0.75	0.77	0.80	0.83	0.88	0.92	0.96	1.01	1.06	1.11	1.17	1.22	1.27	1.32	1.38	1.43
80	0.98	0.92	0.90	0.89	0.89	0.91	0.93	0.96	0.99	1.02	1.07	1.11	1.15	1.20	1.24	1.29	1.34	1.38	1.43
85	1.12	1.07	1.04	1.03	1.02	1.03	1.04	1.06	1.08	1.11	1.14	1.17	1.20	1.24	1.27	1.31	1.35	1.39	1.43
90	1.24	1.21	1.19	1.18	1.17	1.17	1.18	1.19	1.20	1.21	1.23	1.25	1.27	1.30	1.32	1.35	1.38	1.40	1.43
95	1.35	1.34	1.33	1.33	1.32	1.32	1.32	1.33	1.33	1.34	1.34	1.35	1.36	1.37	1.38	1.39	1.41	1.42	1.43
98	1.39	1.39	1.39	1.39	1.39	1.39	1.39	1.40	1.40	1.40	1.40	1.41	1.41	1.41	1.42	1.42	1.42	1.43	1.43

**Table B2-1. Dry Retention BMP Mean Annual Pollutant Load Reduction for Various Stormwater Treatment Volumes as a Function of DCIA and non-DCIA Curve Number for Meteorological Zone 2.**

(From Evaluation of Current Stormwater Design Criteria within the State of Florida, Final Report Submitted to the FDEP, June 2007, Harvey Harper and David Baker, Environmental Research and Design, Inc.)

**Mean Annual Mass Removal Efficiencies for 0.25-inches of Retention in Zone 2**

NDCIA CN	Percent DCIA																				
	0	5	10	15	20	25	30	35	40	45	50	55	60	65	70	75	80	85	90	95	100
30	56.9	94.4	90.4	83.0	75.1	68.0	61.9	56.6	52.1	48.3	44.9	42.0	39.4	37.2	35.1	33.3	31.7	30.2	28.8	27.6	26.4
35	53.4	91.8	88.8	82.0	74.5	67.6	61.5	56.4	51.9	48.1	44.8	41.9	39.4	37.1	35.1	33.3	31.7	30.2	28.8	27.6	26.4
40	51.0	88.2	86.6	80.6	73.5	66.9	61.1	56.0	51.7	47.9	44.7	41.8	39.3	37.1	35.0	33.2	31.6	30.2	28.8	27.6	26.4
45	48.0	83.9	83.8	78.7	72.3	66.1	60.4	55.6	51.4	47.7	44.5	41.7	39.2	37.0	35.0	33.2	31.6	30.1	28.8	27.6	26.4
50	45.5	78.8	80.4	76.4	70.7	64.9	59.6	55.0	50.9	47.3	44.2	41.5	39.0	36.8	34.9	33.1	31.5	30.1	28.8	27.6	26.4
55	43.3	73.2	76.4	73.6	68.7	63.5	58.6	54.2	50.3	46.9	43.9	41.2	38.8	36.7	34.8	33.0	31.5	30.1	28.7	27.5	26.4
60	41.4	67.4	71.8	70.2	66.3	61.7	57.3	53.2	49.6	46.3	43.4	40.8	38.6	36.5	34.6	32.9	31.4	30.0	28.7	27.5	26.4
65	39.8	61.4	66.7	66.3	63.4	59.5	55.6	51.9	48.6	45.5	42.9	40.4	38.2	36.2	34.4	32.8	31.3	29.9	28.7	27.5	26.4
70	38.5	55.7	61.1	61.8	59.8	56.8	53.5	50.4	47.3	44.6	42.1	39.8	37.7	35.9	34.1	32.6	31.1	29.8	28.6	27.5	26.4
75	37.4	50.1	55.2	56.5	55.6	53.5	50.9	48.3	45.7	43.3	41.1	39.0	37.1	35.4	33.8	32.3	30.9	29.7	28.5	27.4	26.4
80	36.3	45.0	49.1	50.7	50.6	49.4	47.6	45.6	43.6	41.6	39.7	37.9	36.2	34.7	33.2	31.9	30.7	29.5	28.4	27.4	26.4
85	35.2	40.3	43.2	44.5	44.8	44.3	43.4	42.1	40.7	39.2	37.8	36.3	35.0	33.7	32.5	31.3	30.2	29.2	28.2	27.3	26.4
90	33.6	36.0	37.5	38.3	38.6	38.5	38.1	37.5	36.7	35.9	35.0	34.0	33.1	32.2	31.3	30.4	29.5	28.7	27.9	27.2	26.4
95	31.2	31.7	32.1	32.3	32.4	32.3	32.2	32.0	31.7	31.4	31.0	30.6	30.2	29.7	29.3	28.8	28.3	27.9	27.4	26.9	26.4
98	29.3	29.3	29.3	29.2	29.1	29.0	28.9	28.8	28.6	28.5	28.3	28.2	28.0	27.8	27.7	27.5	27.3	27.1	26.9	26.6	26.4

**Mean Annual Mass Removal Efficiencies for 0.50-inches of Retention in Zone 2**

NDCIA CN	Percent DCIA																				
	0	5	10	15	20	25	30	35	40	45	50	55	60	65	70	75	80	85	90	95	100
30	72.7	97.0	96.7	94.8	91.7	87.9	83.8	79.7	75.7	71.9	68.4	65.2	62.1	59.4	56.9	54.5	52.3	50.3	48.4	46.7	45.1
35	70.3	95.2	95.5	93.8	90.9	87.3	83.4	79.3	75.4	71.7	68.3	65.0	62.1	59.3	56.8	54.4	52.3	50.3	48.4	46.7	45.1
40	68.0	92.9	94.0	92.5	89.9	86.5	82.7	78.9	75.1	71.4	68.0	64.9	61.9	59.2	56.7	54.4	52.2	50.2	48.4	46.7	45.1
45	66.3	90.2	91.9	90.9	88.6	85.5	81.9	78.2	74.6	71.1	67.7	64.6	61.7	59.1	56.6	54.3	52.2	50.2	48.4	46.7	45.1
50	64.6	86.7	89.2	88.9	87.0	84.2	80.9	77.4	73.9	70.5	67.3	64.3	61.5	58.9	56.5	54.2	52.1	50.2	48.3	46.6	45.1
55	62.3	82.7	86.1	86.4	84.9	82.6	79.6	76.4	73.1	69.9	66.8	63.9	61.2	58.6	56.3	54.1	52.0	50.1	48.3	46.6	45.1
60	60.4	78.5	82.6	83.4	82.5	80.6	78.0	75.1	72.1	69.1	66.1	63.4	60.8	58.3	56.0	53.9	51.9	50.0	48.2	46.6	45.1
65	58.7	74.2	78.6	79.8	79.5	78.1	76.0	73.5	70.7	68.0	65.3	62.7	60.2	57.9	55.7	53.6	51.7	49.9	48.2	46.6	45.1
70	57.3	69.8	74.2	75.8	76.0	75.2	73.5	71.4	69.1	66.6	64.2	61.8	59.5	57.3	55.3	53.3	51.4	49.7	48.1	46.5	45.1
75	55.9	65.4	69.6	71.4	71.9	71.5	70.4	68.8	66.9	64.9	62.7	60.6	58.6	56.6	54.7	52.8	51.1	49.5	47.9	46.5	45.1
80	54.7	61.4	64.9	66.6	67.3	67.2	66.5	65.5	64.1	62.5	60.8	59.0	57.3	55.5	53.9	52.2	50.7	49.2	47.7	46.4	45.1
85	53.5	57.6	60.1	61.6	62.2	62.3	62.0	61.3	60.4	59.3	58.1	56.8	55.4	54.0	52.7	51.3	50.0	48.7	47.4	46.2	45.1
90	52.1	54.1	55.4	56.2	56.7	56.8	56.7	56.4	55.9	55.2	54.5	53.6	52.8	51.8	50.9	49.9	48.9	47.9	46.9	46.0	45.1
95	49.6	50.1	50.5	50.7	50.8	50.8	50.8	50.6	50.4	50.2	49.9	49.5	49.1	48.7	48.2	47.7	47.2	46.7	46.1	45.6	45.1
98	47.8	47.8	47.7	47.7	47.6	47.6	47.5	47.4	47.2	47.1	46.9	46.8	46.6	46.5	46.3	46.1	45.9	45.7	45.5	45.3	45.1



**Mean Annual Mass Removal Efficiencies for 0.75-inches of Retention in Zone 2**

NDCIA CN	Percent DCIA																				
	0	5	10	15	20	25	30	35	40	45	50	55	60	65	70	75	80	85	90	95	100
30	81.1	97.9	98.2	97.5	96.2	94.4	92.1	89.6	86.9	84.1	81.3	78.5	75.9	73.3	70.9	68.5	66.3	64.2	62.2	60.4	58.6
35	78.9	96.7	97.3	96.8	95.6	93.8	91.7	89.2	86.6	83.8	81.1	78.4	75.7	73.2	70.8	68.5	66.3	64.2	62.2	60.4	58.6
40	77.4	95.0	96.1	95.9	94.8	93.1	91.1	88.7	86.2	83.5	80.8	78.2	75.6	73.1	70.7	68.4	66.2	64.2	62.2	60.4	58.6
45	75.9	93.0	94.7	94.6	93.7	92.2	90.3	88.1	85.6	83.1	80.5	77.9	75.4	72.9	70.6	68.3	66.2	64.1	62.2	60.4	58.6
50	74.6	90.7	92.8	93.1	92.4	91.1	89.3	87.3	85.0	82.5	80.0	77.5	75.1	72.7	70.4	68.2	66.1	64.0	62.1	60.3	58.6
55	73.4	88.0	90.6	91.1	90.7	89.7	88.1	86.3	84.1	81.8	79.4	77.0	74.7	72.4	70.1	68.0	65.9	64.0	62.1	60.3	58.6
60	71.7	84.8	87.9	88.8	88.7	88.0	86.7	85.0	83.0	80.9	78.7	76.5	74.2	72.0	69.8	67.8	65.8	63.8	62.0	60.3	58.6
65	70.1	81.5	84.9	86.2	86.3	85.8	84.8	83.4	81.7	79.8	77.8	75.7	73.6	71.5	69.5	67.5	65.5	63.7	61.9	60.2	58.6
70	68.8	78.1	81.7	83.1	83.5	83.2	82.5	81.4	80.0	78.4	76.6	74.7	72.8	70.9	68.9	67.1	65.2	63.5	61.8	60.2	58.6
75	67.6	74.9	78.1	79.6	80.2	80.2	79.8	79.0	77.9	76.5	75.0	73.4	71.7	70.0	68.3	66.5	64.8	63.2	61.6	60.1	58.6
80	66.5	71.6	74.3	75.8	76.5	76.7	76.5	76.0	75.2	74.1	73.0	71.7	70.3	68.8	67.3	65.8	64.3	62.8	61.4	60.0	58.6
85	65.3	68.6	70.6	71.8	72.5	72.8	72.7	72.4	71.9	71.2	70.3	69.3	68.3	67.1	65.9	64.7	63.5	62.2	61.0	59.8	58.6
90	64.1	65.7	66.9	67.7	68.1	68.3	68.3	68.2	67.9	67.5	66.9	66.3	65.6	64.9	64.0	63.2	62.3	61.4	60.5	59.5	58.6
95	62.2	62.7	63.0	63.2	63.3	63.4	63.4	63.3	63.2	63.0	62.8	62.5	62.2	61.8	61.4	61.0	60.5	60.1	59.6	59.1	58.6
98	60.8	60.8	60.8	60.8	60.7	60.7	60.6	60.5	60.4	60.3	60.2	60.1	59.9	59.8	59.6	59.5	59.3	59.2	59.0	58.8	58.6

**Mean Annual Mass Removal Efficiencies for 1.00-inches of Retention in Zone 2**

NDCIA CN	Percent DCIA																				
	0	5	10	15	20	25	30	35	40	45	50	55	60	65	70	75	80	85	90	95	100
30	86.5	98.5	98.8	98.5	97.9	96.9	95.6	94.1	92.3	90.4	88.4	86.3	84.2	82.1	80.0	77.9	75.9	74.0	72.2	70.3	68.6
35	84.3	97.5	98.2	98.0	97.4	96.5	95.3	93.7	92.0	90.2	88.2	86.2	84.1	82.0	79.9	77.9	75.9	74.0	72.1	70.3	68.6
40	83.1	96.4	97.3	97.2	96.8	95.9	94.8	93.3	91.7	89.9	87.9	85.9	83.9	81.8	79.8	77.8	75.8	73.9	72.1	70.3	68.6
45	82.1	94.8	96.1	96.3	96.0	95.2	94.1	92.7	91.2	89.4	87.6	85.6	83.6	81.6	79.6	77.7	75.8	73.9	72.1	70.3	68.6
50	80.9	93.0	94.8	95.2	94.9	94.3	93.3	92.0	90.5	88.9	87.1	85.3	83.3	81.4	79.5	77.5	75.6	73.8	72.0	70.3	68.6
55	79.8	91.0	93.2	93.7	93.6	93.1	92.3	91.1	89.8	88.2	86.6	84.8	82.9	81.1	79.2	77.3	75.5	73.7	72.0	70.2	68.6
60	78.9	88.8	91.2	92.0	92.0	91.7	91.0	90.0	88.8	87.4	85.9	84.2	82.4	80.7	78.9	77.1	75.3	73.6	71.9	70.2	68.6
65	77.7	86.2	88.9	89.9	90.2	90.0	89.5	88.7	87.6	86.4	85.0	83.4	81.8	80.2	78.5	76.8	75.1	73.4	71.8	70.2	68.6
70	76.5	83.6	86.4	87.5	88.0	88.0	87.6	86.9	86.1	85.1	83.8	82.5	81.0	79.5	77.9	76.4	74.8	73.2	71.6	70.1	68.6
75	75.4	81.0	83.6	84.9	85.5	85.6	85.3	84.9	84.2	83.4	82.4	81.2	80.0	78.6	77.2	75.8	74.3	72.9	71.5	70.0	68.6
80	74.6	78.6	80.8	82.0	82.5	82.8	82.7	82.4	81.9	81.3	80.5	79.6	78.5	77.4	76.3	75.0	73.8	72.5	71.2	69.9	68.6
85	73.6	76.1	77.7	78.7	79.3	79.6	79.7	79.5	79.2	78.8	78.2	77.5	76.7	75.9	74.9	74.0	72.9	71.9	70.8	69.7	68.6
90	72.5	73.9	74.8	75.5	75.9	76.1	76.2	76.2	76.0	75.7	75.3	74.9	74.4	73.8	73.2	72.5	71.8	71.0	70.3	69.4	68.6
95	71.1	71.5	71.8	72.0	72.1	72.2	72.2	72.2	72.1	72.0	71.9	71.7	71.4	71.2	70.9	70.6	70.2	69.9	69.5	69.0	68.6
98	70.2	70.2	70.2	70.2	70.2	70.1	70.1	70.1	70.0	69.9	69.8	69.7	69.7	69.6	69.4	69.3	69.2	69.0	68.9	68.8	68.6

**Mean Annual Mass Removal Efficiencies for 1.25-inches of Retention in Zone 2**

NDCIA CN	Percent DCIA																				
	0	5	10	15	20	25	30	35	40	45	50	55	60	65	70	75	80	85	90	95	100
30	90.1	98.9	99.1	99.0	98.7	98.1	97.3	96.4	95.2	93.9	92.4	90.9	89.3	87.7	86.0	84.3	82.6	80.9	79.2	77.6	76.0
35	88.3	98.1	98.6	98.6	98.3	97.7	97.0	96.1	94.9	93.7	92.3	90.8	89.2	87.6	85.9	84.2	82.5	80.9	79.2	77.6	76.0
40	86.9	97.2	98.0	98.0	97.8	97.3	96.6	95.7	94.6	93.4	92.0	90.5	89.0	87.4	85.8	84.1	82.5	80.8	79.2	77.6	76.0
45	86.3	96.1	97.1	97.3	97.1	96.7	96.1	95.2	94.2	93.0	91.7	90.3	88.8	87.2	85.6	84.0	82.4	80.7	79.1	77.6	76.0
50	85.5	94.7	96.0	96.4	96.3	96.0	95.4	94.6	93.6	92.5	91.3	89.9	88.5	87.0	85.4	83.8	82.2	80.7	79.1	77.5	76.0
55	84.4	93.0	94.8	95.3	95.3	95.1	94.6	93.9	93.0	91.9	90.8	89.5	88.1	86.7	85.2	83.6	82.1	80.6	79.0	77.5	76.0
60	83.5	91.3	93.3	94.0	94.1	94.0	93.6	92.9	92.2	91.2	90.1	88.9	87.7	86.3	84.9	83.4	81.9	80.4	78.9	77.5	76.0
65	82.8	89.4	91.6	92.4	92.7	92.6	92.3	91.8	91.1	90.3	89.3	88.3	87.1	85.8	84.5	83.1	81.7	80.3	78.8	77.4	76.0
70	81.9	87.5	89.6	90.6	91.0	91.0	90.8	90.4	89.8	89.1	88.3	87.4	86.3	85.2	83.9	82.7	81.4	80.0	78.7	77.3	76.0
75	81.0	85.4	87.4	88.5	89.0	89.1	89.0	88.7	88.3	87.7	87.0	86.2	85.3	84.3	83.3	82.1	80.9	79.7	78.5	77.3	76.0
80	80.2	83.4	85.2	86.2	86.7	86.9	86.9	86.7	86.4	86.0	85.5	84.8	84.1	83.3	82.3	81.4	80.4	79.3	78.2	77.1	76.0
85	79.5	81.6	82.9	83.7	84.2	84.4	84.5	84.4	84.2	84.0	83.6	83.1	82.5	81.9	81.2	80.4	79.6	78.8	77.9	76.9	76.0
90	78.6	79.7	80.5	81.0	81.4	81.6	81.7	81.7	81.7	81.5	81.3	80.9	80.6	80.1	79.7	79.1	78.6	78.0	77.4	76.7	76.0
95	77.6	77.9	78.2	78.4	78.5	78.6	78.7	78.7	78.6	78.6	78.4	78.3	78.2	78.0	77.8	77.5	77.3	77.0	76.7	76.3	76.0
98	77.1	77.1	77.1	77.1	77.1	77.1	77.1	77.0	77.0	76.9	76.9	76.8	76.8	76.7	76.6	76.5	76.4	76.3	76.2	76.1	76.0

**Mean Annual Mass Removal Efficiencies for 1.50-inches of Retention in Zone 2**

NDCIA CN	Percent DCIA																				
	0	5	10	15	20	25	30	35	40	45	50	55	60	65	70	75	80	85	90	95	100
30	92.8	99.2	99.4	99.3	99.1	98.7	98.2	97.6	96.8	95.9	94.9	93.7	92.5	91.3	89.9	88.6	87.2	85.7	84.3	82.9	81.5
35	91.2	98.6	99.0	99.0	98.8	98.5	98.0	97.4	96.6	95.7	94.7	93.6	92.4	91.2	89.8	88.5	87.1	85.7	84.3	82.9	81.5
40	90.0	97.8	98.4	98.5	98.4	98.1	97.6	97.1	96.3	95.5	94.5	93.4	92.2	91.0	89.7	88.4	87.1	85.7	84.3	82.9	81.5
45	89.0	96.9	97.8	98.0	97.9	97.6	97.2	96.7	96.0	95.1	94.2	93.1	92.0	90.8	89.6	88.3	87.0	85.6	84.2	82.9	81.5
50	88.6	95.9	96.9	97.2	97.2	97.0	96.7	96.2	95.5	94.7	93.8	92.8	91.8	90.6	89.4	88.2	86.9	85.5	84.2	82.8	81.5
55	87.9	94.6	95.9	96.3	96.4	96.3	96.0	95.6	95.0	94.2	93.4	92.4	91.4	90.3	89.2	88.0	86.7	85.4	84.1	82.8	81.5
60	87.0	93.1	94.7	95.3	95.5	95.4	95.2	94.8	94.3	93.6	92.8	92.0	91.0	90.0	88.9	87.7	86.5	85.3	84.0	82.8	81.5
65	86.3	91.7	93.4	94.1	94.4	94.4	94.2	93.9	93.4	92.8	92.1	91.3	90.5	89.5	88.5	87.4	86.3	85.1	83.9	82.7	81.5
70	85.7	90.1	91.9	92.7	93.0	93.1	93.0	92.7	92.3	91.9	91.2	90.6	89.8	88.9	88.0	87.0	86.0	84.9	83.8	82.6	81.5
75	85.1	88.5	90.2	91.0	91.5	91.6	91.6	91.4	91.1	90.7	90.2	89.6	88.9	88.2	87.4	86.5	85.6	84.6	83.6	82.6	81.5
80	84.4	86.9	88.4	89.2	89.6	89.9	89.9	89.8	89.6	89.3	88.9	88.4	87.9	87.3	86.6	85.9	85.1	84.2	83.3	82.4	81.5
85	83.8	85.4	86.5	87.2	87.6	87.9	88.0	87.9	87.8	87.6	87.3	87.0	86.6	86.1	85.6	85.0	84.4	83.7	83.0	82.3	81.5
90	83.2	84.1	84.7	85.1	85.4	85.6	85.7	85.8	85.7	85.6	85.5	85.3	85.0	84.7	84.4	84.0	83.5	83.1	82.6	82.0	81.5
95	82.4	82.7	82.9	83.1	83.2	83.3	83.3	83.4	83.4	83.4	83.3	83.2	83.1	83.0	82.8	82.6	82.4	82.2	82.0	81.8	81.5
98	82.2	82.2	82.2	82.2	82.2	82.2	82.2	82.2	82.2	82.1	82.1	82.1	82.0	82.0	81.9	81.9	81.8	81.7	81.7	81.6	81.5



**Mean Annual Mass Removal Efficiencies for 1.75-inches of Retention in Zone 2**

NDCIA CN	Percent DCIA																				
	0	5	10	15	20	25	30	35	40	45	50	55	60	65	70	75	80	85	90	95	100
30	95.1	99.4	99.5	99.5	99.4	99.1	98.8	98.3	97.8	97.2	96.4	95.6	94.6	93.6	92.6	91.5	90.4	89.2	88.0	86.8	85.6
35	93.2	98.9	99.2	99.2	99.1	98.9	98.6	98.1	97.6	97.0	96.3	95.4	94.5	93.5	92.5	91.4	90.3	89.2	88.0	86.8	85.6
40	92.2	98.3	98.8	98.9	98.8	98.6	98.3	97.9	97.4	96.8	96.1	95.3	94.4	93.4	92.4	91.4	90.3	89.1	88.0	86.8	85.6
45	91.2	97.5	98.3	98.4	98.4	98.2	97.9	97.5	97.1	96.5	95.8	95.0	94.2	93.2	92.3	91.2	90.2	89.1	87.9	86.8	85.6
50	90.8	96.7	97.6	97.8	97.8	97.7	97.5	97.1	96.7	96.2	95.5	94.8	93.9	93.0	92.1	91.1	90.1	89.0	87.9	86.7	85.6
55	90.4	95.7	96.8	97.1	97.2	97.1	96.9	96.6	96.2	95.7	95.1	94.4	93.6	92.8	91.9	90.9	89.9	88.9	87.8	86.7	85.6
60	89.7	94.5	95.8	96.3	96.4	96.4	96.3	96.0	95.7	95.2	94.6	94.0	93.3	92.5	91.6	90.7	89.8	88.8	87.7	86.7	85.6
65	88.9	93.3	94.7	95.3	95.5	95.6	95.5	95.3	95.0	94.5	94.0	93.4	92.8	92.1	91.3	90.4	89.5	88.6	87.6	86.6	85.6
70	88.4	92.0	93.5	94.2	94.5	94.6	94.5	94.4	94.1	93.7	93.3	92.8	92.2	91.5	90.8	90.1	89.3	88.4	87.5	86.6	85.6
75	87.9	90.8	92.1	92.9	93.2	93.4	93.4	93.3	93.1	92.8	92.4	92.0	91.5	90.9	90.3	89.6	88.9	88.2	87.3	86.5	85.6
80	87.5	89.6	90.7	91.4	91.8	92.0	92.0	92.0	91.9	91.6	91.3	91.0	90.6	90.1	89.6	89.1	88.5	87.8	87.1	86.4	85.6
85	87.1	88.4	89.2	89.8	90.2	90.4	90.5	90.5	90.4	90.3	90.1	89.8	89.5	89.2	88.8	88.4	87.9	87.4	86.8	86.2	85.6
90	86.6	87.3	87.8	88.2	88.4	88.6	88.7	88.8	88.7	88.7	88.6	88.4	88.2	88.0	87.8	87.5	87.2	86.8	86.4	86.0	85.6
95	86.0	86.2	86.4	86.6	86.7	86.8	86.8	86.9	86.9	86.9	86.8	86.8	86.7	86.7	86.6	86.4	86.3	86.1	86.0	85.8	85.6
98	86.0	86.0	86.0	86.0	86.0	86.1	86.1	86.1	86.0	86.0	86.0	86.0	86.0	85.9	85.9	85.9	85.8	85.8	85.7	85.6	85.6

**Mean Annual Mass Removal Efficiencies for 2.00-inches of Retention in Zone 2**

NDCIA CN	Percent DCIA																				
	0	5	10	15	20	25	30	35	40	45	50	55	60	65	70	75	80	85	90	95	100
30	96.7	99.5	99.7	99.6	99.6	99.4	99.1	98.8	98.4	97.9	97.4	96.8	96.1	95.3	94.4	93.6	92.6	91.7	90.7	89.7	88.7
35	94.8	99.2	99.4	99.4	99.4	99.2	99.0	98.6	98.2	97.8	97.3	96.6	95.9	95.2	94.4	93.5	92.6	91.6	90.7	89.7	88.7
40	93.9	98.6	99.0	99.1	99.1	98.9	98.7	98.4	98.0	97.6	97.1	96.5	95.8	95.1	94.3	93.4	92.5	91.6	90.6	89.7	88.7
45	93.0	98.0	98.6	98.8	98.7	98.6	98.4	98.1	97.8	97.4	96.9	96.3	95.6	94.9	94.1	93.3	92.5	91.5	90.6	89.6	88.7
50	92.4	97.3	98.1	98.3	98.3	98.2	98.0	97.8	97.5	97.1	96.6	96.1	95.4	94.7	94.0	93.2	92.4	91.5	90.6	89.6	88.7
55	92.2	96.6	97.4	97.7	97.8	97.7	97.6	97.4	97.1	96.7	96.3	95.8	95.2	94.5	93.8	93.0	92.2	91.4	90.5	89.6	88.7
60	91.7	95.6	96.6	97.0	97.1	97.1	97.0	96.9	96.6	96.3	95.9	95.4	94.9	94.2	93.6	92.8	92.1	91.3	90.4	89.6	88.7
65	91.1	94.5	95.7	96.2	96.4	96.5	96.4	96.3	96.0	95.7	95.4	94.9	94.4	93.9	93.3	92.6	91.9	91.1	90.3	89.5	88.7
70	90.5	93.5	94.7	95.3	95.5	95.7	95.6	95.5	95.3	95.1	94.8	94.4	93.9	93.4	92.9	92.3	91.6	90.9	90.2	89.5	88.7
75	90.1	92.5	93.6	94.2	94.5	94.7	94.7	94.7	94.5	94.3	94.0	93.7	93.3	92.9	92.4	91.9	91.3	90.7	90.1	89.4	88.7
80	89.8	91.5	92.5	93.1	93.4	93.6	93.7	93.6	93.5	93.4	93.2	92.9	92.6	92.2	91.8	91.4	90.9	90.4	89.9	89.3	88.7
85	89.5	90.6	91.3	91.8	92.1	92.3	92.4	92.4	92.4	92.3	92.1	91.9	91.7	91.4	91.1	90.8	90.4	90.0	89.6	89.2	88.7
90	89.1	89.7	90.1	90.5	90.7	90.9	91.0	91.0	91.0	91.0	90.9	90.8	90.6	90.5	90.3	90.1	89.9	89.6	89.3	89.0	88.7
95	88.7	88.9	89.1	89.2	89.3	89.4	89.5	89.5	89.5	89.5	89.5	89.5	89.4	89.4	89.3	89.2	89.2	89.0	88.9	88.8	88.7
98	88.8	88.8	88.8	88.9	88.9	88.9	88.9	88.9	88.9	88.9	88.9	88.9	88.9	88.9	88.8	88.8	88.8	88.8	88.7	88.7	88.7

**Mean Annual Mass Removal Efficiencies for 2.25-inches of Retention in Zone 2**

NDCIA CN	Percent DCIA																				
	0	5	10	15	20	25	30	35	40	45	50	55	60	65	70	75	80	85	90	95	100
30	97.6	99.7	99.7	99.7	99.7	99.6	99.4	99.1	98.8	98.5	98.1	97.6	97.0	96.4	95.8	95.0	94.3	93.5	92.7	91.8	91.0
35	96.2	99.3	99.5	99.6	99.5	99.4	99.2	99.0	98.7	98.3	97.9	97.5	96.9	96.3	95.7	95.0	94.3	93.5	92.7	91.8	91.0
40	95.2	99.0	99.2	99.3	99.3	99.2	99.0	98.8	98.5	98.2	97.8	97.3	96.8	96.2	95.6	94.9	94.2	93.4	92.6	91.8	91.0
45	94.5	98.4	98.9	99.0	99.0	98.9	98.8	98.6	98.3	98.0	97.6	97.2	96.7	96.1	95.5	94.8	94.1	93.4	92.6	91.8	91.0
50	93.9	97.8	98.5	98.6	98.7	98.6	98.5	98.3	98.0	97.7	97.4	97.0	96.5	95.9	95.4	94.7	94.0	93.3	92.5	91.8	91.0
55	93.6	97.2	97.9	98.2	98.2	98.2	98.1	97.9	97.7	97.4	97.1	96.7	96.3	95.8	95.2	94.6	93.9	93.2	92.5	91.7	91.0
60	93.2	96.5	97.3	97.6	97.7	97.7	97.6	97.5	97.3	97.0	96.8	96.4	96.0	95.5	95.0	94.4	93.8	93.1	92.4	91.7	91.0
65	92.8	95.6	96.5	96.9	97.1	97.1	97.1	97.0	96.8	96.6	96.3	96.0	95.6	95.2	94.7	94.2	93.6	93.0	92.3	91.7	91.0
70	92.2	94.6	95.6	96.1	96.3	96.4	96.4	96.4	96.3	96.1	95.8	95.5	95.2	94.8	94.4	93.9	93.4	92.8	92.2	91.6	91.0
75	91.8	93.8	94.7	95.2	95.5	95.7	95.7	95.7	95.6	95.4	95.2	95.0	94.7	94.4	94.0	93.6	93.1	92.6	92.1	91.5	91.0
80	91.5	93.0	93.8	94.3	94.6	94.8	94.9	94.9	94.8	94.7	94.5	94.3	94.1	93.8	93.5	93.1	92.8	92.4	91.9	91.4	91.0
85	91.3	92.3	92.9	93.3	93.6	93.7	93.8	93.9	93.8	93.8	93.7	93.5	93.4	93.1	92.9	92.6	92.4	92.0	91.7	91.3	91.0
90	91.1	91.6	92.0	92.3	92.5	92.6	92.7	92.7	92.7	92.7	92.7	92.6	92.5	92.4	92.2	92.1	91.9	91.7	91.5	91.2	91.0
95	90.9	91.0	91.2	91.3	91.4	91.4	91.5	91.5	91.5	91.6	91.5	91.5	91.5	91.5	91.4	91.4	91.3	91.2	91.1	91.1	91.0
98	90.9	91.0	91.0	91.0	91.0	91.1	91.1	91.1	91.1	91.1	91.1	91.1	91.1	91.1	91.1	91.0	91.0	91.0	91.0	91.0	91.0

**Mean Annual Mass Removal Efficiencies for 2.50-inches of Retention in Zone 2**

NDCIA CN	Percent DCIA																				
	0	5	10	15	20	25	30	35	40	45	50	55	60	65	70	75	80	85	90	95	100
30	98.3	99.7	99.8	99.8	99.8	99.7	99.6	99.4	99.1	98.8	98.5	98.1	97.7	97.2	96.7	96.1	95.5	94.9	94.2	93.5	92.7
35	97.4	99.5	99.6	99.7	99.6	99.6	99.4	99.3	99.0	98.7	98.4	98.0	97.6	97.2	96.6	96.1	95.5	94.8	94.2	93.4	92.7
40	96.3	99.2	99.4	99.5	99.5	99.4	99.3	99.1	98.9	98.6	98.3	97.9	97.5	97.1	96.6	96.0	95.4	94.8	94.1	93.4	92.7
45	95.7	98.7	99.1	99.2	99.2	99.2	99.0	98.9	98.7	98.4	98.1	97.8	97.4	97.0	96.5	95.9	95.4	94.7	94.1	93.4	92.7
50	95.0	98.2	98.8	98.9	98.9	98.9	98.8	98.6	98.4	98.2	97.9	97.6	97.2	96.8	96.4	95.8	95.3	94.7	94.1	93.4	92.7
55	94.7	97.7	98.3	98.5	98.6	98.5	98.5	98.3	98.1	97.9	97.7	97.4	97.0	96.6	96.2	95.7	95.2	94.6	94.0	93.4	92.7
60	94.5	97.1	97.8	98.0	98.1	98.1	98.1	97.9	97.8	97.6	97.4	97.1	96.8	96.4	96.0	95.6	95.1	94.5	93.9	93.3	92.7
65	94.1	96.4	97.1	97.5	97.6	97.6	97.6	97.5	97.4	97.2	97.0	96.8	96.5	96.2	95.8	95.4	94.9	94.4	93.9	93.3	92.7
70	93.6	95.6	96.4	96.8	97.0	97.1	97.1	97.0	96.9	96.8	96.6	96.4	96.1	95.8	95.5	95.1	94.7	94.2	93.8	93.3	92.7
75	93.2	94.8	95.6	96.0	96.3	96.4	96.5	96.4	96.4	96.3	96.1	95.9	95.7	95.5	95.2	94.8	94.5	94.1	93.6	93.2	92.7
80	92.9	94.1	94.8	95.3	95.5	95.7	95.8	95.8	95.7	95.7	95.5	95.4	95.2	95.0	94.8	94.5	94.2	93.8	93.5	93.1	92.7
85	92.8	93.6	94.1	94.4	94.7	94.8	94.9	95.0	95.0	94.9	94.9	94.7	94.6	94.5	94.3	94.1	93.8	93.6	93.3	93.0	92.7
90	92.7	93.1	93.4	93.6	93.8	93.9	94.0	94.1	94.1	94.1	94.0	94.0	93.9	93.8	93.7	93.6	93.4	93.3	93.1	92.9	92.7
95	92.5	92.7	92.8	92.9	93.0	93.0	93.1	93.1	93.1	93.1	93.1	93.1	93.1	93.1	93.1	93.0	93.0	92.9	92.9	92.8	92.7
98	92.6	92.7	92.7	92.7	92.7	92.7	92.8	92.8	92.8	92.8	92.8	92.8	92.8	92.8	92.8	92.8	92.8	92.7	92.7	92.7	92.7



**Mean Annual Mass Removal Efficiencies for 2.75-inches of Retention in Zone 2**

NDCIA CN	Percent DCIA																				
	0	5	10	15	20	25	30	35	40	45	50	55	60	65	70	75	80	85	90	95	100
30	98.8	99.8	99.9	99.9	99.8	99.8	99.7	99.5	99.4	99.1	98.8	98.5	98.2	97.8	97.4	96.9	96.4	95.9	95.3	94.7	94.1
35	98.0	99.6	99.7	99.7	99.7	99.7	99.6	99.4	99.3	99.0	98.8	98.5	98.1	97.8	97.4	96.9	96.4	95.9	95.3	94.7	94.1
40	97.2	99.4	99.5	99.6	99.6	99.5	99.4	99.3	99.1	98.9	98.6	98.4	98.0	97.7	97.3	96.8	96.4	95.8	95.3	94.7	94.1
45	96.6	99.0	99.3	99.4	99.4	99.3	99.2	99.1	98.9	98.7	98.5	98.2	97.9	97.6	97.2	96.8	96.3	95.8	95.2	94.7	94.1
50	96.0	98.6	99.0	99.1	99.2	99.1	99.0	98.9	98.7	98.6	98.3	98.1	97.8	97.5	97.1	96.7	96.2	95.7	95.2	94.7	94.1
55	95.6	98.1	98.6	98.8	98.8	98.8	98.7	98.6	98.5	98.3	98.1	97.9	97.6	97.3	97.0	96.6	96.1	95.7	95.2	94.6	94.1
60	95.4	97.6	98.2	98.4	98.5	98.5	98.4	98.3	98.2	98.0	97.9	97.6	97.4	97.1	96.8	96.4	96.0	95.6	95.1	94.6	94.1
65	95.1	97.0	97.6	97.9	98.0	98.1	98.0	98.0	97.9	97.7	97.6	97.4	97.2	96.9	96.6	96.2	95.9	95.5	95.0	94.6	94.1
70	94.7	96.4	97.0	97.3	97.5	97.6	97.6	97.5	97.5	97.4	97.2	97.1	96.9	96.6	96.3	96.0	95.7	95.3	94.9	94.5	94.1
75	94.4	95.7	96.4	96.7	96.9	97.0	97.1	97.0	97.0	96.9	96.8	96.7	96.5	96.3	96.1	95.8	95.5	95.2	94.8	94.5	94.1
80	94.1	95.1	95.6	96.0	96.3	96.4	96.5	96.5	96.5	96.4	96.3	96.2	96.1	95.9	95.7	95.5	95.3	95.0	94.7	94.4	94.1
85	93.9	94.6	95.0	95.3	95.6	95.7	95.8	95.8	95.8	95.8	95.8	95.7	95.6	95.5	95.3	95.2	95.0	94.8	94.6	94.3	94.1
90	93.9	94.2	94.5	94.7	94.9	95.0	95.0	95.1	95.1	95.1	95.1	95.1	95.0	94.9	94.9	94.8	94.6	94.5	94.4	94.2	94.1
95	93.8	93.9	94.0	94.1	94.2	94.3	94.3	94.3	94.4	94.4	94.4	94.4	94.4	94.4	94.3	94.3	94.3	94.2	94.2	94.1	94.1
98	94.0	94.0	94.0	94.0	94.0	94.1	94.1	94.1	94.1	94.1	94.1	94.1	94.1	94.1	94.1	94.1	94.1	94.1	94.1	94.1	94.1

**Mean Annual Mass Removal Efficiencies for 3.00-inches of Retention in Zone 2**

NDCIA CN	Percent DCIA																				
	0	5	10	15	20	25	30	35	40	45	50	55	60	65	70	75	80	85	90	95	100
30	98.9	99.9	99.9	99.9	99.9	99.8	99.8	99.7	99.5	99.3	99.1	98.9	98.6	98.3	97.9	97.6	97.1	96.7	96.2	95.7	95.1
35	98.5	99.7	99.8	99.8	99.8	99.7	99.7	99.6	99.4	99.2	99.0	98.8	98.5	98.2	97.9	97.5	97.1	96.7	96.2	95.7	95.1
40	98.0	99.5	99.6	99.7	99.7	99.6	99.6	99.5	99.3	99.1	98.9	98.7	98.4	98.1	97.8	97.5	97.1	96.6	96.2	95.7	95.1
45	97.3	99.2	99.4	99.5	99.5	99.5	99.4	99.3	99.2	99.0	98.8	98.6	98.3	98.1	97.7	97.4	97.0	96.6	96.1	95.6	95.1
50	96.8	98.8	99.2	99.3	99.3	99.3	99.2	99.1	99.0	98.8	98.6	98.4	98.2	97.9	97.6	97.3	96.9	96.5	96.1	95.6	95.1
55	96.4	98.4	98.9	99.0	99.1	99.0	99.0	98.9	98.8	98.6	98.5	98.3	98.0	97.8	97.5	97.2	96.9	96.5	96.1	95.6	95.1
60	96.2	98.0	98.5	98.7	98.7	98.7	98.7	98.6	98.5	98.4	98.2	98.1	97.9	97.6	97.4	97.1	96.8	96.4	96.0	95.6	95.1
65	95.9	97.5	98.0	98.3	98.4	98.4	98.4	98.3	98.2	98.1	98.0	97.8	97.6	97.4	97.2	96.9	96.6	96.3	95.9	95.6	95.1
70	95.6	97.0	97.5	97.8	97.9	98.0	98.0	97.9	97.9	97.8	97.7	97.6	97.4	97.2	97.0	96.8	96.5	96.2	95.9	95.5	95.1
75	95.3	96.4	97.0	97.2	97.4	97.5	97.5	97.5	97.5	97.4	97.3	97.2	97.1	96.9	96.8	96.5	96.3	96.1	95.8	95.5	95.1
80	95.0	95.9	96.3	96.6	96.8	97.0	97.0	97.0	97.0	97.0	96.9	96.9	96.8	96.6	96.5	96.3	96.1	95.9	95.7	95.4	95.1
85	94.8	95.4	95.8	96.1	96.2	96.4	96.5	96.5	96.5	96.5	96.5	96.4	96.3	96.3	96.1	96.0	95.9	95.7	95.5	95.3	95.1
90	94.8	95.1	95.4	95.5	95.7	95.8	95.9	95.9	95.9	95.9	95.9	95.9	95.9	95.8	95.8	95.7	95.6	95.5	95.4	95.3	95.1
95	94.9	95.0	95.0	95.1	95.2	95.2	95.3	95.3	95.3	95.3	95.3	95.4	95.4	95.3	95.3	95.3	95.3	95.3	95.2	95.2	95.1
98	95.0	95.0	95.1	95.1	95.1	95.1	95.1	95.1	95.1	95.1	95.1	95.1	95.2	95.2	95.2	95.2	95.2	95.1	95.1	95.1	95.1

**Mean Annual Mass Removal Efficiencies for 3.25-inches of Retention in Zone 2**

NDCIA CN	Percent DCIA																				
	0	5	10	15	20	25	30	35	40	45	50	55	60	65	70	75	80	85	90	95	100
30	99.1	99.9	99.9	99.9	99.9	99.9	99.8	99.8	99.6	99.5	99.3	99.1	98.9	98.6	98.3	98.0	97.7	97.3	96.9	96.4	96.0
35	99.0	99.8	99.8	99.9	99.8	99.8	99.8	99.7	99.6	99.4	99.2	99.0	98.8	98.5	98.3	98.0	97.6	97.3	96.9	96.4	96.0
40	98.4	99.6	99.7	99.7	99.7	99.7	99.7	99.6	99.5	99.3	99.1	99.0	98.7	98.5	98.2	97.9	97.6	97.2	96.8	96.4	96.0
45	97.9	99.4	99.5	99.6	99.6	99.6	99.5	99.4	99.3	99.2	99.0	98.8	98.6	98.4	98.2	97.9	97.5	97.2	96.8	96.4	96.0
50	97.5	99.1	99.3	99.4	99.4	99.4	99.4	99.3	99.2	99.1	98.9	98.7	98.5	98.3	98.1	97.8	97.5	97.2	96.8	96.4	96.0
55	97.1	98.7	99.1	99.2	99.2	99.2	99.2	99.1	99.0	98.9	98.7	98.6	98.4	98.2	98.0	97.7	97.4	97.1	96.8	96.4	96.0
60	96.8	98.4	98.8	98.9	99.0	99.0	98.9	98.9	98.8	98.7	98.5	98.4	98.2	98.0	97.8	97.6	97.3	97.0	96.7	96.4	96.0
65	96.6	98.0	98.4	98.6	98.6	98.7	98.6	98.6	98.5	98.4	98.3	98.2	98.0	97.9	97.7	97.5	97.2	96.9	96.7	96.3	96.0
70	96.4	97.5	97.9	98.2	98.3	98.3	98.3	98.3	98.2	98.2	98.1	98.0	97.8	97.7	97.5	97.3	97.1	96.8	96.6	96.3	96.0
75	96.0	97.0	97.4	97.7	97.8	97.9	97.9	97.9	97.9	97.8	97.8	97.7	97.6	97.4	97.3	97.1	96.9	96.7	96.5	96.3	96.0
80	95.8	96.5	96.9	97.2	97.3	97.4	97.5	97.5	97.5	97.5	97.4	97.4	97.3	97.2	97.1	96.9	96.8	96.6	96.4	96.2	96.0
85	95.6	96.1	96.4	96.7	96.8	96.9	97.0	97.0	97.1	97.1	97.0	97.0	96.9	96.9	96.8	96.7	96.6	96.4	96.3	96.1	96.0
90	95.6	95.9	96.1	96.2	96.3	96.4	96.5	96.5	96.6	96.6	96.6	96.6	96.6	96.5	96.5	96.4	96.3	96.3	96.2	96.1	96.0
95	95.7	95.8	95.8	95.9	96.0	96.0	96.0	96.1	96.1	96.1	96.1	96.1	96.1	96.1	96.1	96.1	96.1	96.1	96.0	96.0	96.0
98	95.8	95.9	95.9	95.9	95.9	95.9	95.9	95.9	96.0	96.0	96.0	96.0	96.0	96.0	96.0	96.0	96.0	96.0	96.0	96.0	96.0

**Mean Annual Mass Removal Efficiencies for 3.50-inches of Retention in Zone 2**

NDCIA CN	Percent DCIA																				
	0	5	10	15	20	25	30	35	40	45	50	55	60	65	70	75	80	85	90	95	100
30	99.2	99.9	99.9	99.9	99.9	99.9	99.9	99.8	99.7	99.6	99.5	99.3	99.1	98.9	98.6	98.4	98.1	97.8	97.4	97.0	96.7
35	99.1	99.8	99.9	99.9	99.9	99.8	99.8	99.8	99.7	99.5	99.4	99.2	99.0	98.8	98.6	98.3	98.0	97.7	97.4	97.0	96.7
40	98.8	99.7	99.8	99.8	99.8	99.8	99.7	99.7	99.6	99.5	99.3	99.2	99.0	98.8	98.5	98.3	98.0	97.7	97.4	97.0	96.7
45	98.5	99.5	99.7	99.7	99.7	99.7	99.6	99.6	99.5	99.4	99.2	99.1	98.9	98.7	98.5	98.2	98.0	97.7	97.4	97.0	96.7
50	98.1	99.3	99.5	99.5	99.5	99.5	99.5	99.4	99.3	99.2	99.1	98.9	98.8	98.6	98.4	98.2	97.9	97.6	97.3	97.0	96.7
55	97.6	98.9	99.2	99.3	99.4	99.4	99.3	99.3	99.2	99.1	99.0	98.8	98.7	98.5	98.3	98.1	97.9	97.6	97.3	97.0	96.7
60	97.3	98.6	99.0	99.1	99.2	99.2	99.1	99.1	99.0	98.9	98.8	98.7	98.5	98.4	98.2	98.0	97.8	97.5	97.3	97.0	96.7
65	97.2	98.3	98.7	98.8	98.9	98.9	98.9	98.8	98.8	98.7	98.6	98.5	98.4	98.2	98.1	97.9	97.7	97.5	97.2	96.9	96.7
70	97.0	97.9	98.3	98.5	98.5	98.6	98.6	98.6	98.5	98.4	98.4	98.3	98.2	98.0	97.9	97.7	97.6	97.4	97.2	96.9	96.7
75	96.7	97.5	97.8	98.1	98.2	98.2	98.3	98.2	98.2	98.2	98.1	98.0	97.9	97.8	97.7	97.6	97.4	97.3	97.1	96.9	96.7
80	96.5	97.1	97.4	97.6	97.7	97.8	97.9	97.9	97.9	97.9	97.8	97.8	97.7	97.6	97.5	97.4	97.3	97.2	97.0	96.8	96.7
85	96.3	96.7	97.0	97.1	97.3	97.4	97.4	97.5	97.5	97.5	97.5	97.5	97.4	97.4	97.3	97.2	97.1	97.0	96.9	96.8	96.7
90	96.2	96.5	96.6	96.8	96.9	97.0	97.0	97.1	97.1	97.1	97.1	97.1	97.1	97.1	97.0	97.0	96.9	96.9	96.8	96.7	96.7
95	96.3	96.4	96.5	96.5	96.6	96.6	96.7	96.7	96.7	96.7	96.7	96.7	96.8	96.8	96.8	96.8	96.7	96.7	96.7	96.7	96.7
98	96.5	96.5	96.5	96.5	96.6	96.6	96.6	96.6	96.6	96.6	96.6	96.6	96.6	96.6	96.6	96.6	96.6	96.7	96.7	96.7	96.7



**Mean Annual Mass Removal Efficiencies for 3.75-inches of Retention in Zone 2**

NDCIA CN	Percent DCIA																				
	0	5	10	15	20	25	30	35	40	45	50	55	60	65	70	75	80	85	90	95	100
30	99.4	99.9	99.9	100.0	100.0	99.9	99.9	99.9	99.8	99.7	99.6	99.4	99.3	99.1	98.9	98.6	98.4	98.1	97.8	97.5	97.2
35	99.2	99.9	99.9	99.9	99.9	99.9	99.9	99.8	99.7	99.6	99.5	99.4	99.2	99.0	98.8	98.6	98.4	98.1	97.8	97.5	97.2
40	99.1	99.8	99.8	99.9	99.8	99.8	99.8	99.7	99.7	99.6	99.5	99.3	99.2	99.0	98.8	98.6	98.3	98.1	97.8	97.5	97.2
45	98.8	99.6	99.7	99.8	99.7	99.7	99.7	99.7	99.6	99.5	99.4	99.2	99.1	98.9	98.7	98.5	98.3	98.1	97.8	97.5	97.2
50	98.5	99.4	99.6	99.6	99.6	99.6	99.6	99.5	99.5	99.4	99.3	99.1	99.0	98.8	98.7	98.5	98.3	98.0	97.8	97.5	97.2
55	98.1	99.1	99.4	99.5	99.5	99.5	99.5	99.4	99.3	99.2	99.1	99.0	98.9	98.7	98.6	98.4	98.2	98.0	97.7	97.5	97.2
60	97.8	98.9	99.2	99.3	99.3	99.3	99.3	99.2	99.2	99.1	99.0	98.9	98.8	98.6	98.5	98.3	98.1	97.9	97.7	97.5	97.2
65	97.6	98.6	98.9	99.0	99.1	99.1	99.1	99.0	99.0	98.9	98.8	98.7	98.6	98.5	98.4	98.2	98.0	97.9	97.7	97.4	97.2
70	97.5	98.3	98.6	98.7	98.8	98.8	98.8	98.8	98.8	98.7	98.6	98.5	98.5	98.3	98.2	98.1	98.0	97.8	97.6	97.4	97.2
75	97.2	97.9	98.2	98.4	98.5	98.5	98.5	98.5	98.5	98.4	98.4	98.3	98.3	98.2	98.1	98.0	97.8	97.7	97.6	97.4	97.2
80	97.0	97.5	97.8	98.0	98.1	98.2	98.2	98.2	98.2	98.2	98.1	98.1	98.0	98.0	97.9	97.8	97.7	97.6	97.5	97.3	97.2
85	96.9	97.2	97.4	97.6	97.7	97.8	97.8	97.9	97.9	97.9	97.9	97.8	97.8	97.8	97.7	97.6	97.6	97.5	97.4	97.3	97.2
90	96.8	97.0	97.1	97.2	97.3	97.4	97.4	97.5	97.5	97.5	97.5	97.5	97.5	97.5	97.5	97.5	97.4	97.4	97.3	97.3	97.2
95	96.8	96.9	97.0	97.0	97.1	97.1	97.2	97.2	97.2	97.2	97.2	97.2	97.2	97.3	97.3	97.3	97.3	97.2	97.2	97.2	97.2
98	97.0	97.0	97.1	97.1	97.1	97.1	97.1	97.1	97.1	97.1	97.2	97.2	97.2	97.2	97.2	97.2	97.2	97.2	97.2	97.2	97.2

**Mean Annual Mass Removal Efficiencies for 4.00-inches of Retention in Zone 2**

NDCIA CN	Percent DCIA																				
	0	5	10	15	20	25	30	35	40	45	50	55	60	65	70	75	80	85	90	95	100
30	99.5	99.9	100.0	100.0	100.0	100.0	99.9	99.9	99.8	99.8	99.7	99.6	99.4	99.3	99.1	98.9	98.7	98.4	98.2	97.9	97.6
35	99.3	99.9	99.9	99.9	99.9	99.9	99.9	99.9	99.8	99.7	99.6	99.5	99.4	99.2	99.0	98.8	98.6	98.4	98.2	97.9	97.6
40	99.3	99.8	99.9	99.9	99.9	99.9	99.8	99.8	99.7	99.7	99.6	99.5	99.3	99.2	99.0	98.8	98.6	98.4	98.2	97.9	97.6
45	99.0	99.7	99.8	99.8	99.8	99.8	99.8	99.7	99.7	99.6	99.5	99.4	99.3	99.1	98.9	98.8	98.6	98.4	98.1	97.9	97.6
50	98.9	99.6	99.7	99.7	99.7	99.7	99.7	99.6	99.6	99.5	99.4	99.3	99.2	99.0	98.9	98.7	98.5	98.3	98.1	97.9	97.6
55	98.5	99.3	99.5	99.6	99.6	99.6	99.6	99.5	99.4	99.4	99.3	99.2	99.1	98.9	98.8	98.6	98.5	98.3	98.1	97.9	97.6
60	98.2	99.1	99.3	99.4	99.4	99.4	99.4	99.4	99.3	99.2	99.2	99.1	99.0	98.8	98.7	98.6	98.4	98.2	98.1	97.8	97.6
65	98.0	98.8	99.1	99.2	99.3	99.3	99.2	99.2	99.1	99.1	99.0	98.9	98.8	98.7	98.6	98.5	98.3	98.2	98.0	97.8	97.6
70	97.9	98.6	98.8	98.9	99.0	99.0	99.0	99.0	99.0	98.9	98.8	98.8	98.7	98.6	98.5	98.4	98.3	98.1	98.0	97.8	97.6
75	97.7	98.2	98.5	98.6	98.7	98.7	98.8	98.8	98.7	98.7	98.6	98.6	98.5	98.4	98.4	98.3	98.2	98.0	97.9	97.8	97.6
80	97.5	97.9	98.1	98.3	98.4	98.4	98.5	98.5	98.5	98.4	98.4	98.4	98.3	98.3	98.2	98.1	98.1	98.0	97.9	97.7	97.6
85	97.3	97.6	97.8	97.9	98.0	98.1	98.1	98.2	98.2	98.2	98.2	98.1	98.1	98.1	98.0	98.0	97.9	97.9	97.8	97.7	97.6
90	97.2	97.4	97.5	97.6	97.7	97.8	97.8	97.8	97.9	97.9	97.9	97.9	97.9	97.9	97.9	97.8	97.8	97.8	97.7	97.7	97.6
95	97.3	97.4	97.4	97.5	97.5	97.5	97.6	97.6	97.6	97.6	97.6	97.7	97.7	97.7	97.7	97.7	97.7	97.7	97.6	97.6	97.6
98	97.5	97.5	97.5	97.5	97.5	97.5	97.5	97.6	97.6	97.6	97.6	97.6	97.6	97.6	97.6	97.6	97.6	97.6	97.6	97.6	97.6





# APPENDIX C. METHODOLOGIES

The methodologies in this Appendix are intended to aid applicants in designing stormwater treatment systems to meet the design and performance criteria of this Manual. These methodologies are by no means the only acceptable method for designing stormwater management systems. Applicants proposing to use alternative methodologies are encouraged to consult with County or SWFWMD staff in a pre-application conference.

## C.1. Methodologies, Recovery Analysis, and Soil Testing for Retention Systems

### C.1.1. Description

“Retention systems” are a family of Best Management Practices (BMPs) designed to store a defined quantity of runoff, allowing it to percolate through vegetation and permeable soils into the shallow ground water aquifer, evaporate, or evapotranspire. Stormwater retention works best using a variety of BMPs throughout the project site. Examples of common retention BMPs include (but are not limited to):

- Retention basins which are constructed or natural depression areas where the basin bottom is graded as flat as possible and turf, seed & mulch (or other equivalent materials) are established to promote infiltration and stabilize the basin slopes. These retention systems are discussed in greater detail in **Section 5.3** of this *Manual*.
- Underground Exfiltration Trenches that are discussed in greater detail in **Section 5.4** of this *Manual*.
- Underground Retention Systems that are discussed in greater detail in **Section 5.5** of this *Manual*.
- Rain gardens are discussed in greater detail in **Section 5.6** of this *Manual*.
- Vegetated treatment swales with or without swale blocks that are discussed in greater detail in **Section 5.7** of this *Manual*.
- Vegetated Natural Buffers that are discussed in greater detail in **Section 5.8** of this *Manual*.
- Pervious pavement with perimeter edge constraints that are discussed in greater detail in **Section 5.9** of this *Manual*.

Each of the BMPs listed above have their individual advantages and disadvantages. Cross-sectional diagrams for each of these BMPs are provided in their respective sections of the *Manual* as noted above. It is not the intent of this section to cover all potential designs. Professional judgment must be used in the design and review of proposed retention BMPs.

The soil’s saturated hydraulic conductivity, depth to the Seasonal High Ground Water Table (SHGWT) and depth to the confining unit (i.e., clay, hardpan, etc.) must be such that the retention system can percolate the Required Treatment Volume (RTV) within a specified time following a storm event. After drawdown has been completed, retention BMPs do not hold any water, thus the systems are normally “dry.” Unlike detention BMPs, the RTV for retention systems is not discharged to surface waters.

Retention systems provide excellent removal of most stormwater pollutants. Substantial amounts of suspended solids, oxygen demanding materials, heavy metals, bacteria, some varieties of pesticides and nutrients such as phosphorus may be removed as runoff percolates through the soil profile.

Besides pollution control, retention systems can be used to promote the recharge of ground water, to prevent saltwater intrusion in coastal areas and maintain ground water levels in aquifer recharge areas. Retention systems can also be used to help meet the runoff volume criteria for systems that discharge to closed basins or land-locked lakes. However, the use of retention systems are not appropriate if they contribute to a violation of Minimum Flows or Levels in the receiving waters, or if they adversely impact wetlands by hydrologic alteration.

### **C.1.2. Required Treatment Volume (RTV)**

The RTV necessary to achieve the required treatment efficiency shall be routed to the retention BMP and percolated into the ground. The required level of nutrient removal is specified in Section 4.3 of this Manual. The RTV and other design criteria for each type of retention BMP is specified in the section of the Manual for that particular BMP.

### **C.1.3. Recovery Time of the RTV**

All retention systems must provide the capacity for the RTV of stormwater to recover to the bottom of the system within 72 hours following a storm event, assuming an average Antecedent Runoff Condition (ARC II). The locations of the RTV (and its corresponding bottom) are shown in the supporting graphic figures of the various BMP Sections noted above. A safety factor of two (2.0) must be used in the recovery analysis of the RTV. Two possible ways to apply this safety factor are:

- Reducing the design saturated hydraulic conductivity rates by half; or
- Designing for the required RTV drawdown to occur within half of the required drawdown time.

The safety factor of two (2.0) is based on the high probability of:

- Soil compaction during clearing and grubbing operations,
- Improper construction techniques that result in additional soil compaction under the retention BMP,
- Inadequate long term maintenance of the retention BMP, and
- Geologic variations and uncertainties in obtaining the soil test parameters for the recovery / mounding analysis (noted in subsequent sections below). These variations and uncertainties are especially suspect for larger retention BMPs.

In retention systems, the RTV recovers (is drawn down or dissipated) by natural soil infiltration into the ground water table, evaporation, or evapotranspiration. The opposite is true for underdrain effluent detention systems, which rely on artificial recovery methods such as underground perforated drainage pipes.

Antecedent Runoff Condition (ARC), formally known as Antecedent Moisture Condition (AMC), refers to the amount of moisture and storage in the soil profile prior to a storm event. Antecedent soil moisture is an indicator of wetness and availability of soil to infiltrate water. The ARC can vary from dry to saturated, depending on the amount of rainfall received prior to a given point in time. Therefore, "average ARC" (ARC II) means the soil is neither dry nor saturated, but at an average moisture condition at the beginning of a storm event when calculating recovery time for retention systems.

**C.1.4. Infiltration Processes**

When stormwater runoff enters the retention BMP, standing water begins to infiltrate. This water percolates into the soil in two distinct stages, either vertically (Stage One) through the BMP bottom (unsaturated flow), or horizontally (Stage Two) through the side slopes (saturated flow). One flow direction or the other will predominate depending (primarily) on:

- The depths to the water table and confining unit (i.e., clay or hardpan) below the bottom of the retention BMP, and
- The soil’s saturated hydraulic conductivity.

The following paragraph briefly describes the two stages of infiltration, and subsequent subsections present accepted methodologies for calculating infiltration rates and recovery times for unsaturated vertical (Stage One) and saturated horizontal (Stage Two) flow.

Initially, the subsurface conditions are assumed to be:

- The depth to the initial water table below the bottom of the BMP.
- Unsaturated soils above the water table.

When the water begins to infiltrate, it is driven downward as unsaturated flow by the combined forces of gravity and capillary action. Once the unsaturated soil below the BMP becomes saturated (fills the voids in the soil), the water table begins to "mound" (refer to Figure C.1.1)

**Figure C.1.1. Ground Water Mounding Beneath a Retention System**

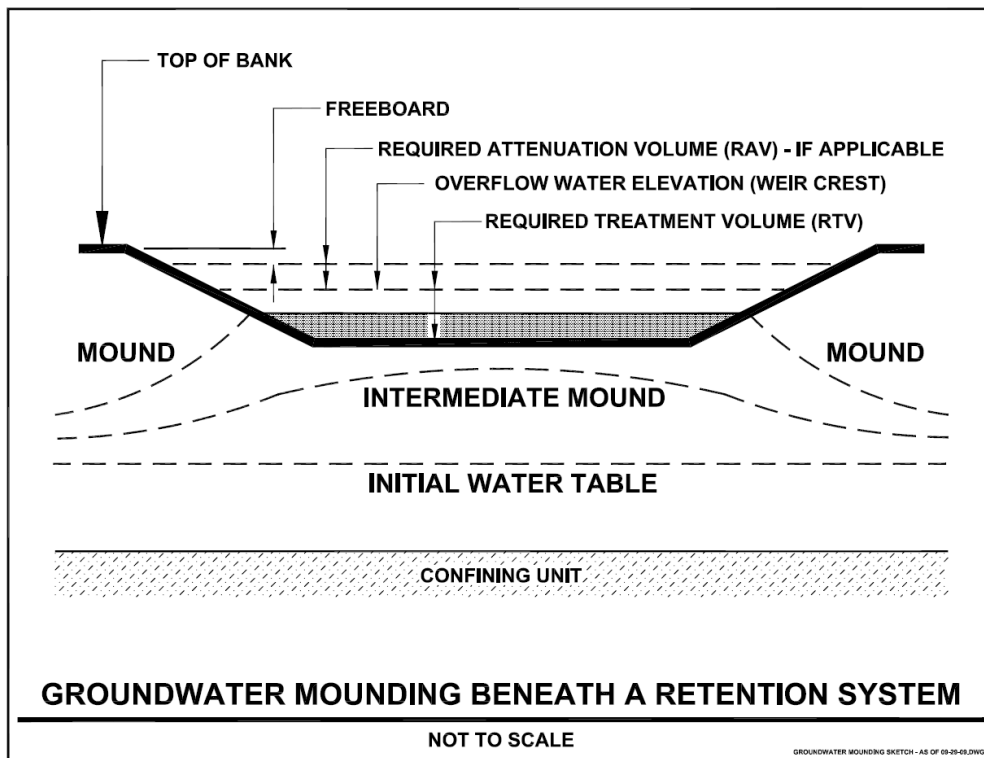

**C.1.5. Accepted Methodologies for Determining Retention BMP Recovery**

1. Acceptable methodologies for calculating retention BMP recovery are presented below in Table C.1.1.

Vertical Unsaturated Flow	Horizontal Saturated Flow
Green and Ampt Equation	Simplified Analytical Method
Hantush Equation	PONDFLOW
Horton Equation	Modified MODRET
Darcy Equation	
Holton Equation	

Several of these methodologies are available in commercial software products. The Agencies can neither endorse any software program nor certify software results.

2. Additional requirements for calculating retention BMP recovery

Unless the normal Seasonal High Ground Water Table (SHGWT) is greater than or equal to 2 feet below the bottom of the BMP system, unsaturated vertical flow prior to saturated horizontal mounding shall be conservatively ignored in the recovery analyses. This is not an unrealistic assumption since the height of the capillary fringe in fine sands is on the order of six (6) inches, and a partially mounded water table condition may be remnant from a previous storm event.

**C.1.6. Requirements, Guidance and Recommendations for Manual Computations or Computer Simulations**

Practicing engineers and hydrogeologists routinely uses computer-based ground water flow models to predict the time for percolation of the Required Treatment Volume (RTV). The reliability of the output of these models cannot exceed the reliability of the input data. Input data assessment is probably the most neglected single task in the ground water modeling process. The accuracy of computer simulations hinges on the quality and completeness of the input data.

The computer models listed in the previous section require input values of the retention BMP dimensions, retained stormwater runoff volume (the RTV) and the following set of aquifer parameters:

- Thickness or elevation of base of mobilized (or effective) aquifer
- Weighted horizontal saturated hydraulic conductivity of mobilized aquifer
- Fillable porosity of mobilized aquifer
- Ambient water table elevation which, for design purposes, is usually the normal Seasonal High Ground Water Table (SHGWT)

Calculated recovery times are most sensitive to the input value for the aquifer’s saturated hydraulic conductivity.

**Determination of Aquifer Thickness**

Standard Penetration Test (SPT) borings are recommended for definition of the aquifer thickness, especially where the ground water table is deep. This type of boring provides a

continuous measure of the relative density/consistency of the soil (as manifested by the SPT "N" values). A relative density - texture (-200 value) better identifies an aquitard or confining unit.

Manual "bucket" auger borings (when supplemented with classification testing) can also be used to define the thickness of the uppermost aquifer (i.e., the depth to the confining unit), especially for small retention ponds and swales.

#### Definition of SPT "N" Values

The Standard Penetration Test (SPT) consists of driving a split-barrel sampling "spoon" or sampler a distance of 30 cm (12 in) after first "seating" the sampler 15 cm (6 in) by dropping a 63.5 kg (140 lb.) hammer from a height of 76 cm (30 in). In field practice, the sampler is driven to a designated depth through a borehole using a long rod, and the hammer strikes the top end of the rod above the ground surface. The operator counts the number of blows that it takes to advance the sampler each of three 15 cm (6 in) increments. When the sampler has penetrated 45 cm (18 in) into the soil at the bottom of the borehole, the operator adds the number of blows for the second and third increments. This combined number is the result of the SPT and is called the "blow count" and is customarily designated as "N" or the "N value." It directly reflects the penetration resistance of the ground or the soil under investigation.

#### Definition of a Confining Unit

The confining unit is a hydraulically restrictive layer (i.e., a clay layer, hardpan, etc.). For many recovery / mounding simulations, the confining unit can be considered as a restrictive layer that has a saturated hydraulic conductivity an order of magnitude (10 times) less than the soil strata (sands) above. In some cases, the "Physical & Chemical Properties table" [within the older NRCS soil surveys (legacy documents)] identifies these soil strata as having a vertical hydraulic conductivity (permeability by NRCS) of 0.06 to 0.6 inches per hour, with the soil above having a permeability of 0.6 to 6.0 inches per hour.

Another method to supplement the identification of a confining unit is to carefully review the SPT boring logs for increases in the SPT "N" values. SPT "N" values (blow counts) alone should be avoided as the primary method to identify a confining unit.

#### Definition of a Hardpan

A hardpan is a hardened or cemented soil horizon or layer. The soil material is sandy, loamy, or clayey and is cemented by iron oxide, silica, calcium carbonate or other substances.

#### Definition of a Spodic Horizon

Florida's pine Flatwoods areas typically have a spodic horizon into which organic matter has accumulated. In many cases, this spodic horizon is locally called a hardpan. Pine Flatwoods are the most predominant natural landscape in Florida, comprising approximately 8.4 million acres.

#### Estimated Normal Seasonal High Ground Water Table ([SHGWT](#))

In estimating the normal SHGWT, the contemporaneous measurements of the water table are adjusted upward or downward taking into consideration numerous factors, including:

- Antecedent rainfall
- Soils on the project site.
- Examination of the soil profile, including redoximorphic features, SPT "N" values, depth to "hardpan" or other impermeable horizons (such as clayey fine sands and clays), etc.

- Consistency of water levels with adjacent surface water bodies and knowledge of typical hydraulic gradients (water table slopes).
- Vegetative indicators
- Effects of existing and future development, including drainage ditches, modification of land cover, subsurface drains, irrigation, septic tank drainfields, etc.
- Hydrogeologic setting, including the potentiometric surface of Floridian aquifer and degree of connection between the water table aquifer and the Floridian aquifer.
- Soil Morphological Features

In general, the measurement of the depth to the ground water table is less accurate in SPT borings when drilling fluids are used to maintain an open borehole. Therefore, when SPT borings are drilled, it may be necessary to drill an auger boring adjacent to the SPT to obtain a more precise stabilized water table reading. In poorly drained soils (HSG “B/D” and “D”), the auger boring should be left open, preferably using Piezometer pipe, long enough (at least 24 hours) for the water table to stabilize in the open hole.

If there is ground water relief within the footprint of the pond, the average ground water contour should be considered representative of the pond.

#### Estimation of Horizontal Hydraulic Conductivity of Aquifer

The following hydraulic conductivity tests are required for retention BMPs:

- Laboratory hydraulic conductivity test on an undisturbed sample (constant or falling head)
- Uncased or fully screened auger hole
- Cased hole with uncased or screened extension with the base of the extension at least one (1) foot above the confining layer
- Pump test, when accuracy is important and hydrostratigraphy is conducive to such a test method.
- Slug Test(s)

Of the above methods, the most cost-effective is the laboratory hydraulic conductivity test on an undisturbed horizontal sample. However, it becomes difficult and expensive to obtain undisturbed hydraulic conductivity tube samples under the water table or at depths greater than 5 feet below ground surface.

Pump tests are the most expensive of the recommended hydraulic conductivity test methods. Therefore, it is recommended that pump tests be used in cases where the effective aquifer is relatively thick (greater than 10 feet) and where the environmental, performance, or size implications of the system justifies the extra cost of such a test.

When the aquifer is layered, it is possible to combine several layers and consider the resulting medium as homogenous. If the flow through such layers is mainly horizontal, the arithmetic mean of the hydraulic conductivity estimates of the individual layers should be used to obtain the weighted horizontal hydraulic conductivity of the mobilized aquifer as follows:



$$k_h = \frac{k_1 z_1 + k_2 z_2 + \dots + k_n z_n}{Z}$$

where the formation consists of n horizontal isotropic layers of different thickness z, and Z is the combined thickness. Note that these layers are above the restrictive layer of hardpan or clayey material. Since the most permeable layer will control the value of the weighted hydraulic conductivity, it is important that the hydraulic conductivity of this layer be tested.

For design purposes of all retention BMPs, a saturated hydraulic conductivity value over forty (40) feet per day will not be allowed for fine-grained sands, and sixty (60) feet per day for medium-grained sands.

If the mobilized aquifer is thick with substantial saturated and unsaturated zones, it is worthwhile to consider performing a laboratory permeameter test on an undisturbed sample from the upper unsaturated profile and also performing one of the in-situ tests to characterize the saturated portion of the aquifer.

#### Estimation of Fillable Porosity

In Florida, the receiving aquifer system for retention BMPs predominantly comprises poorly graded (i.e., relatively uniform particle size) fine sands. In these materials, the water content decreases rather abruptly with the distance above the water table and thus has a well-defined capillary fringe.

Unlike the hydraulic conductivity parameter, the fillable porosity of the poorly graded fine sand aquifers in Florida are in a narrow range (20 to 30%), and can be estimated with much more reliability.

For fine sand aquifers, it is therefore recommended that a fillable porosity in the range of 20% to 30% be used in infiltration calculations.

The higher values of fillable porosity will apply to the well- to excessively-drained, hydrologic group "A" fine sands, which are generally deep, contain less than 5% by weight passing the U.S. No. 200 (0.074 mm) sieve, and have a natural moisture content of less than 5%.

No specific field or laboratory testing requirement is recommended, unless there is a reason to obtain a more precise estimate of fillable porosity. In such a case, it is recommended that the following equation be used to compute the fillable porosity:

$$\text{Fillable porosity} = (0.9 N) - (w \gamma_d / \gamma_w)$$

Where: N = total porosity

W = natural moisture content (as a fraction)

$\gamma_d$  = dry unit weight of soil

$\gamma_w$  = unit weight of water

Maximum depth to the SHGWT and confining unit for the required recovery/mounding analysis:

The maximum depths that will be allowed to the SHGWT and the top of the confining unit will be the higher values of:

- The field confirmed SHGWT or confining unit depth(s) from the boring(s) / test pit(s), or
- The termination depth of the field boring / test pit if a SHGWT or confining unit is not encountered.

Requirements and recommendations regarding constructed breaches in the confining unit

- A detention or retention BMP shall not be excavated to a depth that breaches an aquitard such that it would allow for lesser quality water to pass, either way, between the two systems. In those geographical areas where there is not an aquitard present, the depth of the pond shall not be excavated to within two (2) feet of the underlying limestone which is part of a drinking water aquifer.
- Standard Penetration Test (SPT) borings will be required for any type of deep BMP that has the potential for breaching an aquitard.

### **C.1.7. Requirements, Guidance and Recommendations for BMP Soil Testing**

One of the most important steps in the evaluation of a stormwater BMPs is determining which test methods and how many tests should be conducted per system. Typically, soil borings and saturated hydraulic conductivity measurements are conducted for each BMP. Soil testing requirements listed in this Section of the Manual represent the minimum. It is the responsibility of the registered professional to determine if additional soil borings and hydraulic saturated conductivity tests beyond the minimum are needed due to site conditions. Additional tests shall be required if initial testing results deviate to such an extent that they do not provide reasonable assurance that the site conditions are represented by the data provided.

Standard Penetration Test (SPT) borings or auger borings are commonly used to determine the subsurface soil and ground water table conditions. Test borings provide a reasonable soil profile and an estimate of the relative density of the soils. However, measurement of the ground water table depth from SPT borings is usually less accurate than from auger borings. Measurement of hydraulic conductivity requires more specialized tests as described in the previous section.

To measure saturated infiltration, several methods are employed in both the laboratory and in the field. Generally, laboratory tests require collection of an “undisturbed” sample of soil, in either the vertical or horizontal condition, often by means of a Shelby tube. Measurements are performed on the sample via a constant head or falling head condition in a laboratory permeameter. Other methods that involve “remolding” of the soil sample are generally not as accurate as the undisturbed sample methodology.

Field methods for measuring saturated hydraulic conductivity include auger hole tests, piezometer tests, and pumping tests. Although these tests can be more time consuming, they test a larger volume of soil and generally provide more representative results.

Restrictions on the use of double ring infiltrometer tests

The double-ring infiltrometer field test is used for estimating in-situ infiltration rates. If used, these tests must be conducted at the depth of the proposed pond bottom, and shall only be used to obtain the initial “unsaturated” hydraulic conductivity. Once the ground water mound rises to the BMP bottom, the results of a double-ring infiltrometer test are not valid. The rate obtained using the double ring infiltrometer is divided by 2 to obtain the infiltration rate during flowing conditions (e.g. swales).

Requirements for soil testing

Information related to soils must include the following:

- Soils test results shall be included as part of a supporting soils/geotechnical report of a project’s ERP application. This report must be certified by the appropriate Florida registered professional.
- For all soil borings that are used to estimate the depth to the Seasonal High Ground Water Table (SHGWT), the soil colors shall be denoted by both their English common name and their corresponding Munsell color notation (i.e., light yellowish brown – 10YR 6/4).
- Soil test locations shall be located on the construction drawings, or as an option, the permit review drawings that are submitted as part of the ERP application to the Agency. The horizontal locations of the soil borings/tests shall be placed on the appropriate plan sheet(s), and vertical locations of the soil borings/tests shall be placed on the appropriate retention BMP cross-section(s). The designation number of each test on the plan or cross-section sheets shall correspond to the same test number in the supporting soils/geotechnical report (i.e., SPT #1, Auger boring #2, hydraulic conductivity test #3, etc.).
- The vertical datum of the soil tests results shall be converted to the same datum of the plan sheets and retention BMP cross-sections. For instance, the geo-technical consultant’s certified report shows the top of the confining unit in SPT #1 as six (6.0) feet Below Land Surface (BLS). The design consultant of record must then convert this BLS data to the vertical datum of the cross-section sheet for the BMP (NGVD29, NAVD88, or another vertical datum specified by the appropriate regulatory agency).

The location and number of soil borings and saturated hydraulic conductivity tests performed are usually based on the various site characteristics and requires considerable professional judgment and experience in the decision process. **At a minimum, the following number of tests will be required for each proposed BMP unless the specific BMP design criteria do not require soil testing:**

The minimum number of required Soil Borings - The greater of the following two criteria:

- One (1) for each BMP, drilled to at least ten (10) feet below the bottom of the proposed BMP system. For instance, if a BMP has a pond bottom 5 feet below existing land surface, the minimum boring depth will be 15 feet below existing land surface.
- For BMPs larger than 0.25 acre, retention systems within Sensitive Karst Areas, complex hydrogeology, appreciable topographic relief under the retention BMP, or areas that been filled or otherwise disturbed to change the site’s soil characteristics such as in certain urban areas or reclaimed mined lands:

$$B = 1 + \sqrt{2A} + \frac{L}{2OW}$$

Where:

**B** = number of required borings under each retention BMP, drilled to at least ten (10) feet below the bottom of the proposed BMP system. For instance, if a retention pond has a pond bottom 5 feet below existing land surface, the minimum boring depth will be 15 feet below existing land surface (rounded up or down to the next whole number).

**A** = average BMP area in acres (measured at the control elevation)

**L** = length of the BMP in feet (length is the longer of the dimensions)

**W** = width of the BMP, in feet

$\pi$  = PI, approximately 3.14

- For swales, a minimum of one boring shall be taken for each 500 linear feet or for each soil type that the swale will be built on.

For the recovery / mounding analysis, SPT borings should be continuously sampled at least two (2.0) feet into the top of the hydraulically restrictive layer. If a restrictive layer is not encountered, the boring shall be extended to at least ten (10) feet below the bottom of the pond / system. As a minimum, the depth of the exploratory borings should extend to the base elevation of the aquifer assumed in analysis, unless nearby deeper borings or well logs are available.

Minimum number of required Saturated Hydraulic Conductivity tests - At a minimum, the following number of tests will be required for each proposed BMP unless the specific BMP design criteria do not require saturated hydraulic conductivity testing. The greater of the following two criteria:

- One (1) for each BMP, taken no shallower than the proposed bottom of the BMP system, or deeper if determined by the design professional to be needed for the particular site conditions. However, if the system will be built on excessively drained soils, the applicant may propose a lesser number of tests based on plans, test results, calculations or other information, that the number of tests is appropriate for the specific site conditions.
- For BMPs larger than 0.25 acre, retention systems within Sensitive Karst Areas, complex hydrogeology, appreciable topographic relief under the retention BMP, or urbanized (or reclaimed mining) areas that have undergone previous soil disturbance:

$$P = 1 + (B / 4)$$

Where:

**P** = number of saturated hydraulic conductivity tests for each retention BMP, taken no shallower than the proposed bottom of the retention system, or deeper if determined by the design professional to be needed for the particular site conditions (rounded up or down to the next whole number). However, if the system will be built on excessively drained soils, the applicant may propose a lesser number of tests based on plans, test results, calculations or other information, that the number of tests is appropriate for the specific site conditions.

**B** = number of required borings (from above).

- For wet detention, stormwater harvesting, or underdrain BMPs that have the potential for impacting adjacent wetlands or potable water supply wells, the hydraulic conductivity tests will be required between the location of the BMP and the adjacent wetlands or well.

### C.1.8. Sediment Sump Design Example

(From FDEP-WMD Applicant's Handbook Volume I Design Aids, Section 3)

#### 3 — Sediment Sump Design Example

A horizontal-flow sump or sediment basin must remove the particles under peak flow conditions. The length of the sediment sump or basin will be governed by the depth required by the settling velocity of the particle, and the cross-sectional area will be governed by the rate of flow.

A length to depth ratio for the sediment sump or basin can be calculated:

$$\text{Flow through velocity (V}_d\text{)} = \frac{\text{length of sump (l)} \times \text{Settling velocity (V}_s\text{)}}{\text{depth of sump (h)}}$$

The cross-sectional area (A) required for peak flow (Q<sub>p</sub>) at a flow through velocity (V<sub>d</sub>):

$$Q_p = A V_d$$

$$A = \frac{Q_p}{V_d}$$

The cross-sectional area (A) is the width of the sump (W) multiplied by the depth of the sump (h):

$$A = Wh$$

The sump can be sized using these equations:

$$l = \frac{V_d h}{V_s}$$

$$Q_p = V_d Wh$$

Where:

- Q<sub>p</sub> = design peak rate of flow
- V<sub>d</sub> = flow through velocity
- V<sub>s</sub> = settling velocity
- l = length of sump
- W = width of sump
- h = depth of sump

V<sub>s</sub> is the settling velocity for a discrete particle using Stokes Law:

$$V_s = \frac{gd^2(S_s - 1)}{18\gamma}$$

Where:

- V<sub>s</sub> = settling velocities
- S<sub>s</sub> = specific gravity of particle
- γ = kinematic viscosity
- d = diameter of particle
- g = acceleration due to gravity

Remember that the Reynolds number for flow must be less than one for Stokes Law to apply.



Given the following, calculate the settling velocity, the flow through velocity and the sump dimensions:

- d = 0.01 cm sand particle
- S<sub>s</sub> = 2.65 for sand particle
- γ = 1.31 x 10<sup>-2</sup> cm<sup>2</sup>/sec with water at 20°C
- g = 981 cm/sec<sup>2</sup>

$$V_s = \frac{981 \times 0.01^2 \times (2.65 - 1)}{18 \times 1.31 \times 10^{-2}} = 0.69 \frac{cm}{sec}$$

$$V_s = \frac{0.69 \text{ cm}}{s} \left( \frac{0.3937 \text{ in}}{cm} \right) \left( \frac{1 \text{ ft}}{12 \text{ in}} \right) = 0.23 \frac{ft}{s}$$

V<sub>d</sub> is the flow through velocity which must be less than the velocity required to transport the design particle:

$$V_d = \frac{8 K'}{f} g d (S_s - 1)$$

$$V_d = \left( \frac{8(0.06)}{0.03} \right) (32.2) \left( \frac{0.00394}{12} \right) (2.65 - 1) = 0.26 \frac{ft}{s}$$

- Where:
- V<sub>d</sub> = velocity required to transport water born particle
  - d = diameter of the particle = 0.01 cm = 0.0394 inches
  - f = Darcy-Weisbach friction factor = 0.03
  - K' = Cohesiveness factor of particle = 0.06  
(clean grit = 0.04, sticky = 0.8)
  - S<sub>s</sub> = Specific gravity of particle = 2.65
  - g = acceleration due to gravity = 32.2 ft/sec<sup>2</sup>

To determine the sediment sump dimensions given the following:

$$\begin{aligned} V_d &= 0.26 \text{ ft/sec} & l &= (h V_d)/V_s \\ V_s &= 0.023 \text{ ft/sec} \\ Q_p &= 25 \text{ cfs} & w &= Q_p/(h V_d) \end{aligned}$$

By fixing one of the variables (w, h, l), the others can be calculated:  
If h = 3.5 feet, then:

$$l = \frac{h V_d}{V_s} = \frac{3.5 \times 0.26}{0.023} = 39.56 \text{ ft}$$

$$w = \frac{Q_p}{h V_d} = \frac{25}{3.5 \times 0.26} = 27.47 \text{ ft}$$

# APPENDIX D. STORMWATER RETROFIT PROJECTS

## Description

Since a substantial amount of development in Alachua County occurred before the implementation of Florida's Stormwater Treatment Rule in 1982, a major challenge facing the county's residents is how to "retrofit" the county's existing "drainage systems" to provide stormwater treatment. An urban stormwater retrofit is a project that adds treatment to an existing stormwater management system serving existing land uses that results in reduced stormwater pollutant loadings. Generally, retrofit projects are large regional stormwater systems that are constructed by the public sector and do not serve new development or redevelopment. Examples include Depot Park and the Paynes Prairie Sheetflow Restoration Projects. However, retrofit projects can also include a public-private partnership wherein the part of the treatment capacity is reserved for future development or redevelopment.

## Goals and Performance Standards

Section 62-40.432(2)(c), F.A.C., states that pollutant loading from older stormwater management systems shall be reduced as necessary to restore or maintain the designated uses of waters. Load reduction requirements established in adopted TMDLs or BMAPs should be considered in the design of retrofit projects to maximize load reduction credits. If the applicant has conducted, and the County has approved, an analysis that provides reasonable assurance that the proposed retrofit will provide the intended pollutant load reduction from the existing system or systems, the retrofit project will not be required to comply with the performance standards set forth in Section 4.3 of this Manual. The applicant for a retrofit project must provide reasonable assurance that the retrofit project itself will not result in new adverse water quality and quantity impacts to receiving waters.

## Design and Selection of Applicable BMPs

The applicant must conduct a feasibility assessment to determine which BMP(s) and design criteria provide the greatest pollutant removal in the most cost-effective manner given the limitations of the project site. When site conditions allow, stormwater retrofit BMPs shall be designed to the BMP design criteria set forth in this Manual. However, in many cases, site constraints commonly encountered in existing, developed areas can limit the type and size of stormwater BMPs used for retrofitting. In addition to the traditional treatment BMPs specified in this Manual, a number of other BMPs may be suitable for regional retrofitting projects including "stormwater parks" and alum injection systems. However, it is best to select BMPs for retrofit projects that provide the greatest "bang for the buck" in reducing stormwater pollutants.